

CONNECTING VET TEACHERS TO **AGRICULTURE 4.0**

Teaching agricultural informatics in agricultural vocational training

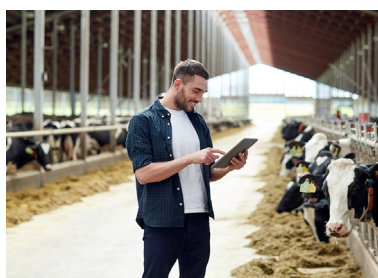

**HOW CAN AGRICULTURAL VET TEACHERS
REFORM THEIR TEACHING METHODS?**



Connecting VET Teachers to Agriculture 4.0

An EU Erasmus+
KA2 Strategic Partnership project
No. 2017-1-HU01-KA202-035964

+



This work is licensed under a
Creative Commons Attribution 4.0 International (CC BY 4.0) License.

AGRITEACH 4.0

CONNECTING VET TEACHERS TO AGRICULTURE 4.0

ELEARNING TEXTBOOK



PUBLISHED BY AGRITEACH 4.0 CONSORTIUM

WRITTEN BY:

Preface text

Zoltán Horváth - Galamb József Agricultural Secondary School

Module 1

Mária Hartyányi, Anita Téringér, Szilvia Gerhát - iTStudy Hungary Educational and Research Centre

Module 2

László Dr. Papócsi - GAK Educational, Research and Innovation Nonprofit Ltd.

Module 3

Zoltán Horváth - Galamb József Agricultural Secondary School

Blagoja Mukanov - AgFutura Technologies

László Dr. Papócsi - GAK Educational, Research and Innovation Nonprofit Ltd.

Pavel Šimek, Zbyněk Křivánek, Jan Jarolímek, Jiří Vaněk – Wirelessinfo

Zsófia Veres – AgriDrón Ltd.

English language proofreading

Ken Currie - CAPDM Ltd.

Cover design, layout and editing

Ken Currie - CAPDM Ltd.

Szilvia Gerhát - iTStudy Hungary Educational and Research Centre

Project coordinator

Galamb József Agricultural Vocational School, Makó

If you have any questions regarding this book or the project from which it originated

Contact: Horváth Zoltán –director

Phone: +36 62 510-896

Email: galambj.iskola@gmail.com

Project website: www.agriteach.hu

Elearning site: <http://moodle.agriteach.hu/>



The European Commission's support for the production of this publication does not constitute an endorsement of the contents, which reflect the views only of the authors, and the Commission cannot be held responsible for any use which may be made of the information contained therein.

Co-funded by the
Erasmus+ Programme
of the European Union



CONTENTS

1	WELCOME.....	9
2	RETHINKING EDUCATION FOR THE 21ST CENTURY	11
2.1	EDUCATION	12
2.2	NEEDS OF THE LABOUR MARKET, 21ST CENTURY SKILLS	13
2.2.1	21 ST CENTURY SKILLS.....	14
2.2.2	EU KEY COMPETENCES.....	14
2.2.3	DIGITAL COMPETENCE FRAMEWORK FOR CITIZENS	15
2.3	LEARNING ATTITUDES OF A NEW GENERATION OF STUDENTS.....	16
2.4	ACTIVE LEARNING METHODS	16
2.5	THE CHANGING ROLE OF THE TEACHERS	17
2.6	EDUCATION FOR FARMING 4.0	18
2.7	DIGITAL EDUCATION RESOURCES AND TOOLS	19
2.8	OPEN EDUCATIONAL RESOURCES (OERS).....	20
2.8.1	THE IDEA OF 'OPENNESS'	20
2.8.2	OPENING UP EDUCATION.....	20
2.9	CREATIVE COMMONS	21
2.9.1	CC LICENSE TYPES	21
2.10	OPEN EDUCATIONAL REPOSITORIES.....	22
2.10.1	OPENLEARN	22
2.10.2	MERLOT.....	23
2.10.3	AGRICULTURAL REPOSITORIES	23
2.10.4	LRE - LEARNING RESOURCE EXCHANGE.....	24
2.10.5	TED – ED.....	24
2.10.6	TEACHERS PAY TEACHERS (TPT)	24
2.10.7	TELU.....	25
2.10.8	OPEN PROFESSIONALS EDUCATION NETWORK.....	26
2.11	DIGITAL CONTENT CREATION	27
2.12	TOOLS FOR CREATING DIFFERENT TYPES OF EDUCATIONAL VIDEOS.....	28
2.12.1	PREPARATION	28
2.12.2	TURNING IMAGES INTO VIDEO IN MINUTES - ANIMOTO	29
2.12.3	ATTRACTIVE PRESENTATION – SWAY.....	29
2.12.4	PEDAGOGICAL APPLICATIONS.....	30
2.12.5	SIMPLE VIDEO MAKER – BITEABLE	30
2.12.6	AWESOME VIDEOS – POWTOON.....	31
2.12.7	SCREEN VIDEO - SCREENCAST-O-MATIC.....	31
2.12.8	VIDEO EDITOR - OPENSHOT	32
2.12.9	MAKING VIDEOS INTERACTIVE WITH H5P.....	32
2.13	COLLABORATIVE LEARNING WITH CONCEPT MAPS	33
2.13.1	PEDAGOGICAL USE	33
2.14	PRACTICING ONLINE – LEARNINGAPPS	34
2.15	SOCIAL MEDIA IN TEACHING	35

2.15.1	SYMBALOO	35
2.15.2	PINTEREST.....	37
2.15.3	ONLINE NOTICE BOARD - LINOIT	38
2.16	PUBLISHING DIGITAL CONTENT	39
2.16.1	SOCIAL SOFTWARE, CONTENT SHARING SITES	39
2.16.2	SHARING VIDEOS.....	40
2.16.3	SHARING PRESENTATIONS – SLIDESHARE.....	41
2.16.4	PERSONAL WEB PAGES	41
2.16.5	BLOGGING.....	42
2.16.6	VIRTUAL CLASSROOM	42
3	21ST CENTURY PEDAGOGY	44
3.1	PROJECT-BASED LEARNING.....	44
3.1.1	A PROJECT-BASED LEARNING FREE ONLINE COURSE.....	45
3.1.2	RESEARCH-BASED LEARNING	46
3.1.3	PROBLEM-BASED LEARNING	47
3.2	FLIPPED CLASSROOM	47
3.3	GAMIFICATION IN EDUCATION.....	50
3.3.1	JOURNEY 2050	50
3.3.2	TOP CROP – FARMING FOR THE FUTURE	51
3.4	ONLINE TOOLS FOR LEARNING ENGLISH	51
3.4.1	FREE ONLINE LANGUAGES COURSES.....	51
3.4.2	PRACTISING GRAMMAR	52
3.4.3	SUMMARY.....	54
	MODULE 1 GLOSSARY	55
4	WHAT IS E-AGRICULTURE?	62
4.1	WHY E-AGRICULTURE IS IMPORTANT?.....	62
4.1.1	STATUS OF E-AGRICULTURE IN THE REGION	63
4.1.2	PLETHORA OF DEFINITIONS AND SIMILAR CONCEPTS	64
5	EU POLICY FOR DEVELOPMENT OF INNOVATION AND ICT	65
5.1	EIP-AGRI.....	66
5.2	H2020	68
5.2.1	H2020 PROJECTS RELATED TO DIGITAL AGRICULTURE.....	68
5.3	EARTH OBSERVATION	71
5.3.1	COPERNICUS PROGRAMME.....	71
5.3.2	EO DATA SOURCES.....	72
5.3.3	USING COPERNICUS EO SERVICES IN CAP MONITORING	73
6	INFORMATION SYSTEMS IN THE COMMON AGRICULTURAL POLICY	76
6.1	THE INTEGRATED ADMINISTRATION AND CONTROL SYSTEM.....	77
6.2	OTHER CAP RELATED INFORMATION SYSTEMS	78
6.2.1	FARM ACCOUNTANCY DATA NETWORK (FADN)	78
6.2.2	MARKET PRICE INFORMATION SYSTEM.....	79
6.2.3	EUROSTAT	79

7	STRATEGIC MANAGEMENT OF E-AGRICULTURE	80
7.1	STANDARDS	80
7.1.1	USING METADATA DESCRIPTIONS FOR AGRICULTURE	82
7.2	OPEN DATA.....	85
7.2.1	FAIR DATA	86
7.2.2	LINKED OPEN DATA	87
7.2.3	FIIVE STARS OF OPEN DATA	88
7.3	INTEROPERABILITY	89
7.3.1	SEMANTICS FOR INTEROPERABILITY OF AGRICULTURAL DATA.....	89
7.3.2	CIARD RING	90
7.3.3	FARM MACHINES	90
7.3.4	ABOUT APIS, WEB SERVICES	90
7.3.5	FILE LEVEL INTEROPERABILITY - FILE FORMATS AND CONVERSIONS.....	91
7.4	THE GUIDE	91
7.4.1	THE STRUCTURE OF THE GUIDE:	92
8	AGRICULTURAL KNOWLEDGE AND INNOVATION SYSTEMS	94
8.1.1	THE PRO AKIS PROJECT	95
8.2	FARM ADVISORY SERVICE IN THE EU	96
8.2.1	EUFRAS.....	96
8.2.2	SEASN	97
8.3	ICTS IN FARM ADVISORY SERVICES	97
8.3.1	INTEGRATED ICT-ASSISTED FARM ADVISORY SERVICE - SYSTEM DESIGN	97
8.3.2	ISSUE TRACKING SYSTEM	98
8.3.3	CLIENT DATABASE / FARMER REGISTER	100
8.3.4	FARM PROFILE.....	100
8.3.5	DECISION SUPPORT	101
8.3.6	KNOWLEDGE BASE	102
8.3.7	FARMER FOLDER	102
8.3.8	APPLICATION ASSISTANT	102
8.3.9	E-APPLICATION:	103
8.3.10	REPORTS AND STATISTICS	103
8.4	THE VERCON MODEL	103
8.4.1	THE CHALLENGE	103
8.4.2	WHO IS INVOLVED.....	104
8.4.3	THE APPROACH	105
8.4.4	CONCEPTS AT A GLANCE.....	108
8.4.5	PLATFORMS RELATED TO THE VERCON MODEL	110
8.5	MODULE 2 GLOSSARY.....	111
9	DIGITAL SYSTEMS IN AGRICULTURE 4.0.....	117
10	WHAT IS AGRICULTURE 4.0?.....	119
10.1	TRENDS IN AGRICULTURE 4.0.....	120
10.2	CHALLENGES.....	125

11	DATA SOURCES	127
11.1	DATA SOURCES AND DATABASES.....	127
11.1.1	THE IMPORTANCE OF DATA FOR THE FARMING BUSINESS.....	128
11.1.2	DATA STREAMS.....	129
11.2	SAMPLING	130
11.2.1	TYPES OF SAMPLING.....	131
11.2.2	SOIL SAMPLING.....	131
11.3	SOIL SAMPLING METHODOLOGIES, TECHNIQUES AND DIGITAL TOOLS	133
11.3.1	GRID SAMPLING	133
11.3.2	MANAGEMENT ZONE SAMPLING	134
11.3.3	3D MAPPING.....	135
11.3.4	SOIL MODELLING.....	136
11.3.5	SOIL ZONING.....	137
11.3.6	CROP SAMPLING.....	137
11.3.7	LIVESTOCK SAMPLING.....	138
11.3.8	PRODUCTION SAMPLING.....	139
11.4	SENSORS	140
11.4.1	SOIL SENSORS.....	140
11.4.2	CROP MANAGEMENT: SENSORS FOR MONITORING PLANT HEALTH.....	142
11.4.3	IRRIGATION SENSORS	143
11.4.4	OTHER SENSOR TYPES	144
11.4.5	PLANT NUTRITION SENSORS.....	146
11.4.6	PLANT PROTECTION SENSORS.....	148
11.4.7	YIELD SENSORS.....	150
11.4.8	LIVESTOCK SENSORS.....	152
11.4.9	AIRBORNE SENSORS (UAVS).....	153
11.4.10	APPLIED SENSORS ON AGRICULTURAL MACHINERY.....	154
11.5	OPEN DATA SOURCES	155
11.6	REMOTE SENSING TECHNOLOGY	156
11.6.1	GIS & GPS.....	156
11.6.2	GPS	158
11.7	SATELLITE IMAGE AND SPATIAL DATA.....	159
11.7.1	EUROPEAN IMAGING SOURCES: COPERNICUS	159
11.7.2	SENTINEL MISSIONS	160
11.8	SPECTRAL INDICES	160
11.8.1	USE OF SATELLITE IMAGES IN AGRICULTURAL PRODUCTION.....	161
11.9	USABILITY OF INDIVIDUAL SPECTRAL BANDS IN AGRICULTURAL PRODUCTION	161
11.9.1	SPECTRAL INDICES.....	161
11.10	ORTOPHOTOS.....	162
11.11	WEATHER DATA AND FORECAST	163
12	THE INTERNET OF THINGS (IOT) & AGRICULTURE	165
12.1	HOW IOTS WORK.....	165

12.2	IOT TRENDS & BENEFITS	166
12.3	IOT AGRICULTURAL EXAMPLES.....	167
13	DIGITAL FARM MANAGEMENT EQUIPMENT.....	170
13.1	PRECISION AGRONOMICS.....	170
13.2	PRECISION AGRICULTURE MACHINERY AND EQUIPMENT	171
13.3	COMMONLY USED SYSTEMS.....	171
13.3.1	YIELD MAPPING	171
13.3.2	VARIABLE RATE TECHNOLOGY	173
13.4	AGROTECHNICAL OPERATIONS	174
13.4.1	SOIL PROCESSING	174
13.4.2	HARVESTING.....	175
13.4.3	SOWING	176
13.4.4	SPRAYING, FERTILIZATION, IRRIGATION	177
14	DIGITAL FARM MANAGEMENT SYSTEMS	180
14.1	DATA INTEGRATION	180
14.1.1	DATA INTERMEDIARIES.....	181
14.1.2	FARM SOFTWARE AND SYSTEMS.....	181
14.2	HANDHELDS, TABLETS AND SMARTPHONES	182
14.3	ENTERPRISE INFORMATION SYSTEMS	184
14.4	TRACEABILITY SYSTEMS.....	185
14.4.1	EXTERNAL TRACEABILITY	186
14.4.2	INTERNAL TRACEABILITY	186
14.4.3	RISK MANAGEMENT.....	187
14.5	MODULE 3 GLOSSARY	188
15	APPENDICES	196
15.1	FEEDBACK FROM THE HUNGARIAN PILOT.....	197
15.2	FEEDBACK FROM THE MACEDONIAN PILOT	199

1 WELCOME

Dear Readers,

I am very pleased to be able to present this online textbook to you, which highlights technical advances and innovations in the modernization of agricultural vocational training and modern agricultural solutions.

The technological advancements of agriculture have reached the point where IT tools and solutions have become a crucial and new branch of agriculture. The two professions are becoming more and more connected, forming a new central sector - agricultural informatics – knowledge of which is so important for all those working in agriculture.

A few years ago, we started talking about precision agriculture, including precise soil cultivation techniques, nutrient management solutions, and harvest-related measurements in the crop production branch of agriculture. Nowadays, new IT-supported solutions are gaining ground in all sectors of agricultural production, such as precision animal husbandry, precision horticulture and gardening.

Agricultural informatics has become a complex and constantly developing discipline, of which precision agriculture is only one component.

This book provides an insight into the field of this new discipline, which is fully expected to grow significantly in years to come.

The book attempts to introduce and demonstrate the wide range of IT tools that can be used to collect, process and control all-important data. This, in turn, is enabling the use of innovative technologies in the field of agro-informatics, taking into account – and minimizing – environmental impacts while, at the same time, proving their cost-effectiveness.

I hope that the results of our project help you on your path to learn more about these innovations and advances in agriculture, and with the critical thinking, planning and connections you might need for your own further development.

One of the primary outputs of Agriteach was a three-module online course for VET teachers, available in English (EN), Hungarian (HU) and Macedonian (MK).

- **Module 1** provides an insight into innovative teaching methods, with a focus on online learning. This Intellectual Outcome addresses the criticism of some contemporary teaching practices, as espoused by the Hungarian educational researcher B. Komenczy:
 - *“I do not see much sense in trying to prepare children for using intelligent IT systems of the future by running software from the past on yesterday's computers, using pedagogical methods from the day-before-yesterday.”¹*
- **Module 2** gives an overview of innovations in agriculture education, European and national initiatives, and trends in the agricultural sector as outlined in ICT4Ag[1] and Farming 4.0. \
- **Module 3** introduces the most widely used systems and tools within a practice-oriented approach to precision agriculture and Agriculture 4.0.

Horváth Zoltán
Galamb József Mezőgazdasági Szakképző Iskola
Makó, Hungary

¹ Komenczy B: The public educational strategy of the Information Society, New Pedagogical Review, 1999, July-August

TEACHING IN THE 21ST CENTURY

Module 1

2 RETHINKING EDUCATION FOR THE 21ST CENTURY

Why is it deemed necessary for education to be rethought? Why should approved, tried and tested teaching methods of the past be changed?

The rapid evolution of technology — from vehicles, radio, television, mobile phones, to computers and 'smart' devices — has unquestionably led to advances that have significantly changed significant many practices in our lives today. The changes introduced by 20th century technology to everyday life are irreversible with their transformations in communication, education, business life, work, the purchase of goods, entertainment, or in data storage. Such has been the change that it may even seem that technology has begun to dominate over man.



Figure 1: Group work in the Classroom
(Image source: [Fremtidens Landbrug](#))

What is important that the benefits that technology can bring are suitably harnessed and realized. This is particularly important for the education of our children (as well as grown-ups and parents) and for the educators in charge of that process.

Here is a brief summary of important changes brought about by technology from the viewpoint of education. You may be able to think of other issues that have arisen in this regard.

- **EDUCATION.** Technology has the potential to truly transform many methods and practices in education, as well as the learning process itself. Probably the biggest change has been in the access to data and information which has become available, fast and flexible for nearly everyone. Educators need to be able to utilize the advantages that this technology can bring to their particular areas of education. Can you think of ways in which this enhanced access can improve the learning process for your students?
- **NEEDS OF THE LABOUR MARKET: 21ST-CENTURY SKILLS.** The same technology changes are creating new, and changing existing, professions and occupations. These professions are correspondingly demanding new skills of today's workforce, and hence of today's students. Education needs to be able to Judge which professions will be in demand in the near future, and what skills and abilities will be required of current students. It is essential that they develop to match these needs, so that they will be suitably prepared for tomorrow's life and that their employment chances will be increased. How should educators be re-skilled where necessary to prepare their students for the 21st century?
- **STUDENTS AND TECHNOLOGY.** Today's generation of students is relatively confident and well-practiced in their use of info-communication technologies and digital devices for everyday tasks. How can educators give them the necessary assistance and guidance to apply this ability for their own benefit and self-development? To be effective, technology must enhance or support teaching and learning, but not overshadow or substitute good quality teaching. Any new approaches to teaching and learning should be complemented by knowledge of learning theory and pedagogy. Technology does not guarantee the reduction of the workload on teachers, or facilitate new and better means of learning for students. These benefits can be realized, but it is essential that the technology can appropriately and effectively support learning and that it has a clear role to play in the learning process.

- **CHANGING METHODS OF EDUCATION.** Contemporary ICT-based educational methods arguably have the potential to support student activity to a greater level, and to produce better results for many students. However, these innovative methods need to be evaluated and carefully introduced where suitable and relevant. They include methods such as 'flipped classroom', and active learning but, while digital tools and technologies may provide opportunities for innovations in self-directed, independent learning this is not in itself education. Teachers guide learning. Students may be able to use technologies, but that it does not mean they learn from them, particularly through independent learning activity. Teachers may be introduced to innovative strategies for teaching and learning, but students must be at the heart of any new student-centred, immersive learning experiences.
- **CHANGING ROLES OF TEACHERS.** The role of the teacher is also changing, particularly as information has become so readily available to everyone. The is no longer the sole source of information, so a new role for the teacher is directed at assisting a common and correct elaboration of this information, as well as arranging and filtering the information so that it is appropriate and correct for the needs of the students. How can educators be prepared for this changing role?

This module will look to answer the questions posed above, and will provide means and mechanisms to assist educators with the changes that technology is forcing on them.

2.1 EDUCATION

The rapid development of technology has influenced and changed education.

Students have ready access to many information sources, from all sorts of devices, and expect education to react similarly. Teachers should therefore be able to make use of relevant [online](#) educational tools, resources and materials in their classes to meet the expectations of today's students and to make use of the skills they have developed. Many teachers do make use of tutoring via tools such as YouTube and blogs, and on other [web](#) sites students may be able to participate in [online](#) training, debates, or forums. Visual communication techniques, photos, infographics and videos may also being used to make the whole process of education more attractive and appealing.

Even the communication between students and teachers has been transformed and is not now restricted to that time spent together at school.

Contemporary technological tools alone, however, cannot achieve more efficient or effective teaching. They are only relevant if they fulfill a particular need within the a subject, pedagogy, or methodology. If an educator applies technological tools well, they undoubtedly can support the learning process, make learning more interesting and motivating, and they can enhance student activity. However tried and tested methods must not be abandoned, but used in conjunction to open up opportunities offered by technology.

Technology may well be used more and more in our classrooms, but teachers will be just as important as ever. According to the CEO of Silicon Schools, Brian Greenberg, progressing technology does not endanger the teacher's role in the classroom — but enhances it. There are no good classes without a good educator.

This module will be looking at:

- how to utilize internet resources in teaching materials
- what are open-source teaching material, and how are they found
- a range of free, online tools (e.g. tools for graphic design, collaboration, communication, presentations, surveys) which may be applied to support different educational activities.

These issues are covered in detail in the chapters to follow.



2.2 NEEDS OF THE LABOUR MARKET, 21ST CENTURY SKILLS

The rapidly changing economic and social environment requires a correspondingly constant adaptation from the actors of the economy. This includes vocational education who prepare many of the workforce for the changing labour market.

For this very reason vocational education has been pushed into the limelight in European countries over the past few years, and a reformation and transformation of the development of vocational education is subsequently in progress. The aims are focused on reducing the distance between what education provides and what work requires, for example by enhancing practical education and placing less emphasis on theory- based teaching methods.

Today, employers require workers-to-be that have the key competences that are necessary for employment, i.e. workers a wide range of practical skills and experience, as well as theoretical knowledge. Economic changes are happening very quickly, so students need to be prepared for being able to adjust to new areas, roles and even new jobs at any time. This is why lifelong learning is essential for tomorrow's workforce.

Within such a rapidly changing environment, whether students will eventually become employees or entrepreneurs, they will need to be able to quickly acquire and apply new information. Further, they must exhibit those 21st-century skills that will enable them to perform effectively in the labour market and to be able to react to rapid economic and technological changes. These skills include problem solving, critical thinking, communication, team work, the use of technology, and innovation. To develop these skills, traditional teaching methods are no longer wholly appropriate, which is why it is necessary to introduce innovation in areas such as ACTIVE LEARNING METHODS into vocational education.

There have been many initiatives created for the purpose of comprehensively formulating and collecting 21st-century competences. Some of them will be presented in this module. You are encouraged to review these critically and to judge their suitability for your subject areas. Some things that are common to every approach are: the need for digital [competence](#), the ability to communicate effectively, and for students to take the initiative for learning.

2.2.1 21ST CENTURY SKILLS

The World Economic [Forum](#) has undertaken a multi-year initiative - the New Vision for Education - to examine the pressing issues of the widening skills gaps, and to explore ways of addressing and closing these gaps through judicious use of technology.

The following skills have been defined as the top 21st century skills for students entering into the job market in the future

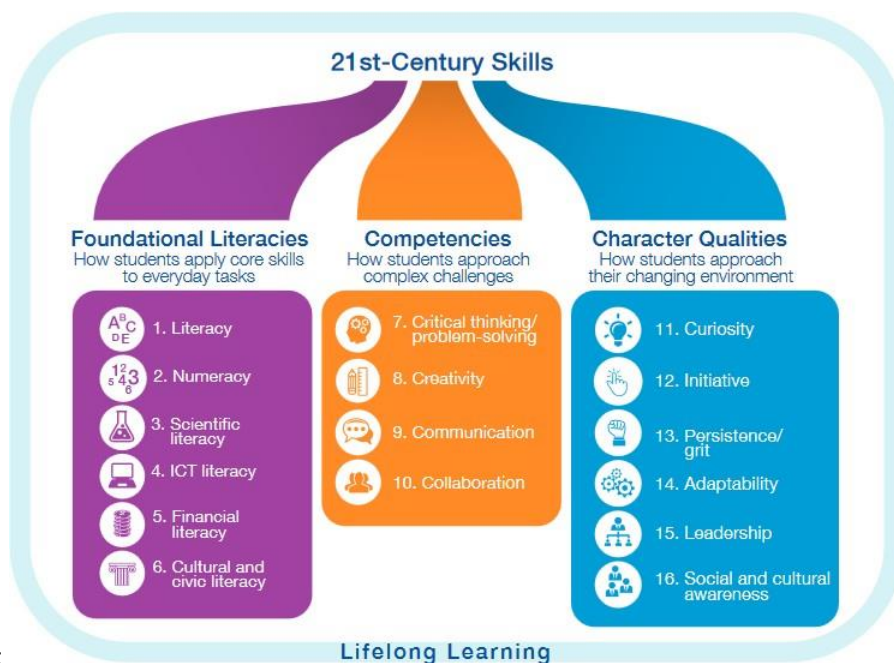

Figure 1: Source: http://www3.weforum.org/docs/WEFUSA_NewVisionforEducation_Report2015.pdf

2.2.2 EU KEY COMPETENCES

The European Commission works with EU countries to strengthen the 'key competences' – knowledge, skills, and attitudes - needed by all member states for personal fulfilment and development, employability, social inclusion and active citizenship.

The key EU competences are:

- Communication in the mother tongue:
- Communication in foreign languages
- Mathematical competence and basic competences in science and technology
- Digital competence
- Learning to learn
- Social and civic competences
- Sense of initiative and entrepreneurship
- Cultural awareness and expression.

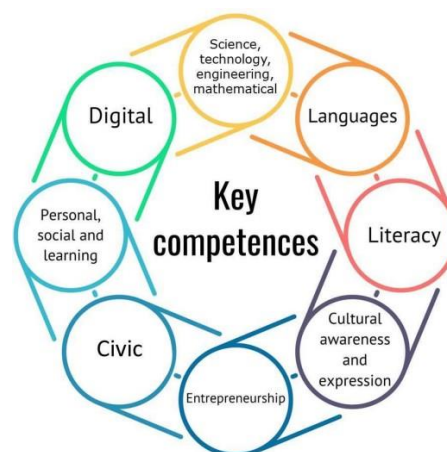

Figure 2: Image source: <https://eur-lex.europa.eu/legal-content/EN/TXT/?uri=SWD:2018:0014:FIN>

2.2.3 DIGITAL COMPETENCE FRAMEWORK FOR CITIZENS

Digital Competence is recognized as one of the eight key competences for lifelong learning by the European Union. It is summarized as “involving the confident and critical use of Information Society Technology (IST) for work, leisure and communication”.

Its importance is highlighted in the flagships of the Europe 2020 strategy, but particularly in the Digital Agenda for Europe 2010.

Information	Communication	Content creation	Safety	Problem solving
<ul style="list-style-type: none"> • Browsing, searching, & filtering information • Expressing information needs • Evaluating information • Storing and retrieving 	<ul style="list-style-type: none"> • Interacting through technologies • Sharing information and content • Engaging in online citizenship • Collaborating through digital technologie • Netiquett • Managing digital identity 	<ul style="list-style-type: none"> • Developing content • Integrating and re-elaborating • Copyright and licenses • Producing multimedia and creative outputs • Programming 	<ul style="list-style-type: none"> • Protecting devices • 4Protecting data and digital identity • Protecting health • Protecting the environment 	<ul style="list-style-type: none"> • Solving technical problems • Identifying needs and technological responses • Creatively using digital technologies • Identifying digital competence gaps

Figure 3: Image source: <https://www.slideshare.net/h2so4/eu-code-week-2016>

The Digital Competence Framework for Citizens - also known as DigComp - was first published in 2013 by the European Commission.

It is a tool to improve citizens' digital competence, help policy-makers formulate policies that support digital competence building, and plan education and training initiatives to improve the digital competence of specific target groups. DigComp also provides a common language on how to identify and describe the key areas of digital competence and thus offers a common reference at European level.

However, the fast moving digitalisation of various aspects of society sets new requirements, hence the need for a DigComp version 2.0 as developed by the Joint Research Centre of the European Commission.

2.3 LEARNING ATTITUDES OF A NEW GENERATION OF STUDENTS

The phenomenon in the picture below is familiar to all of us.

Today's secondary school students are members of the so-called Generation Z - children born between 1995-2009, also known as digital generation - who were born into a digital world. They use info-communication technologies and digital devices with confidence and proficiency having encountered computers and mobile phones as part of their everyday lives from childhood. They take digital devices for granted.

A continued online presence is a characteristic they have. They inhabit virtual communities, and a great part of their free time is spent on the worldwide web. Even relationships may be built on social websites, and many cannot imagine a world without mobile internet or social media.

With this background it is not surprising that social interaction in the classroom is important to them there, as well as in their free time. These relationships can be the generators of learning for them, particularly through team work which must be given particular emphasis in their education.

How can all this be turned to their own good, i.e. to their self-development?



Figure 4: Teens' Cell Phone Use
(Image source: [510 Families](#))

2.4 ACTIVE LEARNING METHODS

Traditional teaching methods tend, not unnaturally, to be centered around the teacher, who transmits knowledge and information to the students in what is generally a one-way communication process.

Learners listen, take notes, and often participate all too passively in the classes. Modern active learning methods are being designed to change this so that students participate much more actively in the overall learning process.

Numerous attempts have been made to introduce these new methods in many countries and schools. However their introduction and application can be a difficult task for schools, for teachers and even for students, not least because they generally sit alongside more traditional methods.

Active learning applies to activities done by students, who also should always reflect on what they are doing. They do not simply receive knowledge passively but actively participate in the learning process. Of course, the transfer of knowledge remains important, but the development of abilities and skills gains a greater significance. Active learning is learner-centered, shifting the emphasis from the teacher and the transfer of the learning materials to the active work of the students with the learning material.

One of the goals of active learning is to ensure that students developing their abilities and skills for lifelong learning.

Active learning methods include the methods of PROBLEM, PROJECT, and RESEARCH-BASED learning as well as the FLIPPED CLASSROOM method. In a later section, the core of these methods will be summarised and the flipped classroom method will be presented in more detail.



2.5 THE CHANGING ROLE OF THE TEACHERS

In the frontal, classical style of teaching, the teacher transmits knowledge to their students, who receive and (hopefully) learn all that knowledge.

At the end of the learning process, the teachers measure - by means of a test - to what extent learners have succeeded in acquiring the learning material, i.e. whether they succeeded in achieving the objectives. The teacher's role is active, while that of the students is much more passive - absorbing information.

"The introduction of active learning methods into the school classrooms has brought about an unambiguous change in the teacher role too. The teacher's earlier distinguished position—in front of the class, or standing in the middle of the class—has also ceased, the educator has rather become a kind of "mobile counsellor," who is learning along with their students and meanwhile labouring to allow greater and greater space to them. For the sake of facilitating active learning, the teacher must become a tutor." (Niemi, Hannele: Active learning, 2005, p. 90)

This new teacher role places teachers in the midst of the learners, though their authority and function are not diminished as a result. It is still very much the teachers who organise and support the learning process. Their role is complex: they stimulate interest, prompt with thought-provoking questions, observe and foster the work of the groups, give help and information, control, offer feedback, guide practice, and evaluate, etc.

The foundation of the learning process is the cooperation between students and teachers.

If you would like to see how a learner-centered class might work, you can start by raising an issue or setting a problem. Then you might divide students into groups, and assign a task which the learners must actively participate in.

Go from group to group, supporting them in their understanding of the problem, and their finding of the solution. However let them arrive at the answer!

If students truly are active members of the learning process, and actively participating in it, then they will gain the desired knowledge through their own work. Carefully moving away from frontal instruction gives students' the autonomy and responsibility for their own learning, and hopefully this will come to the fore.



"I think it's an exaggeration, but that there's a lot of truth in saying that when you go to school, the trauma is that you must stop learning and you must now accept being taught."

— Seymour Papert

Figure 5: Role of Teachers (Image source: College Ready)

2.6 EDUCATION FOR FARMING 4.0

The story with education in agriculture is the same.

IT is being increasingly employed within agriculture to increase production, offer efficiencies and protect the environment. The impact of the different approaches that can be offered through IT and technology can have a significant effect on national economies.

However in agriculture, as in other parts of national economies, there is a shortage of quality manpower and human resource. This is one of the main obstacles to a more widespread adoption of IT solutions in the Hungarian agriculture sector which, according to the Digital Agrarian Strategy (DAS), counts nearly 3,000 "agro-informatics" missing from the sector.



Figure 6: Precision Ag Students
(Image source: [Ellsworth Community College](#))

There is a great need for specialists who are: skilled in IT and agricultural production; able to design applications and operate them; able to educate users and provide counselling.

This brings a new challenge to the education system now, and problems for the future, as it not only requires agrarian engineers and IT professionals, but also the intersection of the two.

The situation of VET schools as providers of that education is made more difficult by the fact that many of these tools are expensive, and without tools it is difficult to solve the practical training problems facing students. Quality skills are also a target need as poorly configured systems can cause damage and lead to poor outcomes.

It is important for teachers in agricultural VET schools to be well-informed and to have up-to-date knowledge, so that they can prepare their students for these new jobs in agriculture. In education, there is a growing requirement to introduce students to the use of innovative and often as yet unknown technologies.

Students must be prepared for a new way of thinking to help to identify the importance and applications of agricultural information for farmers, but also to offer solutions using technological innovations. Students need to see the whole agro-informatics process in a holistic way, not simply a set of individual components. It is important that a student's theoretical and practical training build on and strengthen each other, but this will only be achieved by revising and updating the teaching of technology and solutions.

In preparing teachers for this new challenge, it is clear that they need both agrarian and IT skills. However, it is often the case that for practical tasks schools do not necessarily have the tools that a learner should become acquainted with.

The role of [ICT](#) tools and simulators become an essential. Here are some examples of where IT can come to the rescue:

- Programs for the simulation of farm management systems and feed calculations
- ISOBUS and automatic steering simulators
- Simulating AgroBot operations
- Robot milking simulators
- Educational design programs, e.g. 3D garden planners, CAD programs
- Agricultural chart simulators, e.g. yield maps, traction resistance, moisture maps
- Simulators and educational versions of registration software, e.g. stock records, pesticides logs

Feature films, tutorials and databases on the [web](#) can also play a very important role.

2.7 DIGITAL EDUCATION RESOURCES AND TOOLS



Research results vary in their assessment of whether the use of ICT tools in schools has had a positive impact on student effectiveness.

Some of the experts argue that a greater efficiency in technology-based learning cannot be justified, while others believe that significant development has been achieved with respect to cognitive skills, reading comprehension and mathematics - for example within disadvantaged learning groups.

ICT supported learning can be just as successful used in frontal methods too, as when applied to activity-centred pedagogies involving students. Similarly, practice shows that student motivation and performance can be improved when ICT is used in conjunction with active participation, where the learner also plays a key role alongside the 'knowledge-transferring' teacher.

However there is one very important requirements - that high quality teaching materials, multimedia content, videos, animations and presentations are used in the support of these lessons. This begs the question, where can such resources be found?

There are two possible options:

SEARCH AND REUSE 	CREATE 
<p>There are a substantial amount of high quality Open Educational Resources (OER) available on the net. In this module you will be guided through some platforms where you can find valuable learning materials.</p> <p>We also refer you to websites that offer OERs in different categories, to help you find your way.</p>	<p>There are a huge number of applications you can use when creating digital material for your classes.</p> <p>We have tested and selected ones that we think are easy to learn and use, and which are of great help from a pedagogical point of view.</p> <p>In this module you will find tutorials for key applications, along with advice on the pedagogical application and relevant, based on our own teaching experience.</p>

Whether you collect or create the content for your lessons, you need to make it accessible for your students. To assist you in this process, we are going to suggest some ways for **PUBLISHING** learning materials.

No matter which road you choose, you will always have to consider licencing and rights. An essential factor to learn about is:



This module will talk about how to make sure that you can re-use a material, respecting the rights of the author. It is equally important when you are the author, as you will have to specify what rights you want to keep when publishing your content.

The searching and sorting of teaching materials is an important pedagogical issue, a task that often presents a serious professional challenge for the teacher since the aim is to offer the most suitable resources for the age of their students.

First, let us introduce and get acquainted with the concept of Open Educational Content

2.8 OPEN EDUCATIONAL RESOURCES (OERS)

2.8.1 THE IDEA OF 'OPENNESS'

*"If you have an apple and I have an apple and we exchange apples then you and I will still each have one apple. **But if you have an idea and I have an idea and we exchange these ideas, then each of us will have two ideas.**" (George Bernard Shaw)*

To open or to close? Should we facilitate and encourage access to resources – for example, to land, water, medicine, information, ideas, ... - or should we limit access in order to protect potentially legitimate interests - for example, ownership rights, patents, the right to privacy, or the ownership of an idea?

It is an old issue that possibly acquires new and different thinking in today's digital and globalised world. Nowadays anyone who has a computer and internet access can make gigabytes of music, texts, films and programmes available to everyone without geographical, time and economic constraints (apart from connection costs), not to mention the possibility that everyone can now publish their own ideas, their own photographs, their own films and make them available to everyone. (Pierfranco Ravotto, AICA)

Definition

Open educational resources are **digitized materials offered freely and openly** for educators, students and self-learners to use and reuse for teaching, learning and research.

The end-user should be able not only to use or read the resource but also **to adapt it, build upon it** and thereby **reuse it**, provided that the original creator is attributed for their work. (OECD/CERI)

2.8.2 OPENING UP EDUCATION

As a part of the Digital Agenda for Europe, the '[Opening up Education](#)' initiative focuses on three main areas:

- creating opportunities for organizations, teachers and learners to innovate
- increased use of Open Educational Resources (OER), ensuring that educational materials produced with public funding are available to all
- better ICT infrastructure and connectivity in schools.

"The education landscape is changing dramatically, from school to university and beyond: open technology-based education will soon be a 'must have', not just a 'good-to-have', for all ages. We need to do more to ensure that young people especially are equipped with the digital skills they need for their future. It's not enough to understand how to use an app or program; we need youngsters who can create their own programs. Opening up Education is about opening minds to new learning methods so that our people are more employable, creative, innovative and entrepreneurial,"



(Androulla Vassiliou, Commissioner for Education, Culture, Multilingualism and Youth, 2013)

2.9 CREATIVE COMMONS

Creative Commons (CC) is a non-profit organization, founded in 2001 and aimed at defining the spectrum of possibilities between full copyright - **all rights reserved** - and the public domain - **no rights reserved**. The CC licenses help to keep the copyright while inviting certain uses of the work of the author - a **"some rights reserved"** copyright.



The Creative Commons platform <https://creativecommons.org/> provides an easy-to-use tool to help the sharing of content under one of the standard CC licenses. Click "Share your work", and follow the steps to decide the level of permissions for further use of your creative work, e.g. by answering questions such as "Allow commercial uses of your work?". At the end of the process you can download a digital picture of the selected license, or make a copy of the code. This can be embedded into any **web-based publication**.

CC Search, the Creative Commons search tool, lets you pick a range of general sources and media types that you may want to search for. The CC Search tool automatically filters your search to find Creative Commons licensed resources that you can share, use, and remix.





2.9.1 CC LICENSE TYPES

Each license type is labeled with an icons and abbreviation.

By clicking on the name, you can get detailed descriptions of each license.

1. CC BY	Attribution 4.0 International	
2. CC BY SA	Attribution-ShareAlike 3.0 Unported	
3. CC BY ND	Attribution-NoDerivatives 4.0 International (CC BY-ND 4.0)	
4. CC BY NC	Attribution-NonCommercial 4.0 International (CC BY-NC 4.0)	

5. CC BY NC SA	Attribution-NonCommercial-ShareAlike International (CC BY-NC-SA 4.0) 4.0	
6. CC BY NC ND	Attribution-NonCommercial-NoDerivatives International (CC BY-NC-ND 4.0) 4.0	

“Use Creative Commons tools to help share your work. Our free, easy-to-use copyright licenses provide [a simple, standardized way to give your permission to share and use your creative work](#)— on conditions of your choice. You can adopt one of our licenses by [sharing on a platform](#), or choosing a license above.”

You can read about the six main license types [here](#).

2.10 OPEN EDUCATIONAL REPOSITORIES

Open educational resources (OER) are freely accessible, openly licensed text, media, and other digital assets that are useful for teaching, learning, and assessing as well as for research purposes.

Educational repositories are [online](#) libraries for storing, managing, and sharing digital learning resources. The learning resource can be a quiz, a presentation, an image, a video, or any other kind of document or file or learning materials for educational use.

To publish learning element to a repository, the owner of the objects should provide [metadata](#) to classify and organize the learning elements and make them readily searchable for others.

The learning materials should be classified according to their pedagogical aims. Usually the registered users can also review and rate the learning materials in order to ensure their quality and pedagogical value.

As an exercise find some examples of Educational Repositories and OERs where agriculture-related resources are available.

2.10.1 OPENLEARN

The Open University's (UK) website is particularly useful, with hundreds of free and open educational resources for learners and educators.

The resources cover several subjects: Arts and History, Business and Management, Education, Health and Lifestyle, IT and Computing, Mathematics and Statistics, Modern Languages, Science and Nature, Society, Study Skills, Technology ... but also Agriculture.

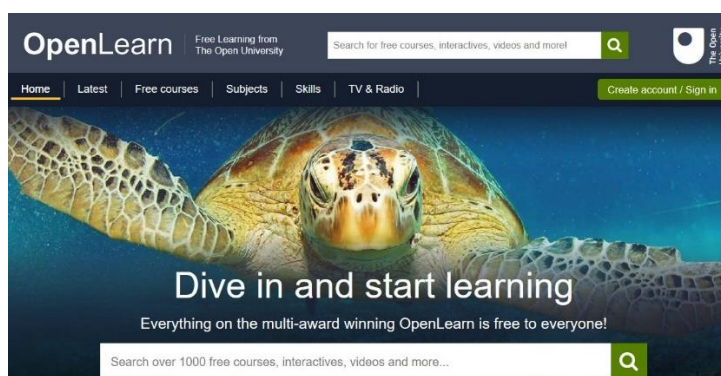

2.10.2 MERLOT

The Merlot [Multimedia](#) Educational Resource for Learning and [Online](#) Teaching is one of the major international repositories. MERLOT is a program at the California State University, working in partnership with higher education institutions, professional societies, and industry.

Search for the keyword 'agriculture' and more than a thousand OERs appear including [online](#) courses, textbooks, collections, animations, presentations, reference materials, case studies, etc.

The screenshot shows the MERLOT search results for 'agriculture'. The page displays 1-24 of 1,034 results. The results are listed in a grid with the following items:

- Sustainable Agriculture**: This site has good information on sustainable agriculture practices. There are 5 modules with this site with activities... see more. Material Type: Online Course. Author: Center for Integrated Agricultural Systems (CIAS) at the University of Wisconsin-Madison. Date Created: oktober 16, 2005. Date Modified: augustus 1, 2018. Editor Review: ★★★★★. User Rating: ★★.
- Practical Agriculture**: This is a digitized text from 1899 made accessible through an online reading platform. The science of agriculture may be... see more. Material Type: Open (Access) Textbook. Author: C. C. James. Date Created: július 14, 2011. Date Modified: július 26, 2018. Editor Review: ★★★★★. User Rating: ★★★★★.
- Agriculture in the Classroom**: This homepage offers links to About AITC, Featured State, State Programs, National Conference, Kids' Corner, and Teacher... see more. Material Type: Collection. Author: US Department of Agriculture. Date Created: május 16, 2009. Date Modified: augustus 20, 2018. Editor Review: ★★★★★. User Rating: ★★★★★.
- Genetic Engineering in Medicine, Agriculture, and Law**: UCLA Course Description Genetic Engineering in Medicine, Agriculture, & Law is a class that examines the historical and... see more. Material Type: Online Course. Author: Bob Goldberg. Date Created: november 5, 2011. Date Modified: február 7, 2012. Editor Review: ★★★★★. User Rating: ★★★★★.
- Georgia Agriculture Education**: Reference Material. Author: unknown.

2.10.3 AGRICULTURAL REPOSITORIES

Fortunately, there are now some specialist agrarian repositories, where free to use resources are available. See the following [links](#):

<p>National Agricultural Library of the United States</p>	<p>One of the world's largest and most accessible agricultural information collections</p>	
<p>FAO Capacity Development</p>	<p>FAO's capacity building portal provides access to almost 600 learning resources, lists over 65 learning services offered by the Organization, and contains a database of funding sources for fellowships. FAO's array of e-learning resources and programmes to date has reached more than 100 000 people.</p>	
<p>Organic Eprints</p>	<p>Organic Eprints is an international open access archive for papers and projects related to research in organic food and farming.</p>	

<p>Turkish Agricultural Learning Objects Repository (TrAgLor)</p>	<p>A multilingual, discipline specific, and IEEE LOM Draft Standard compatible learning objects and learning objects metadata repository. TrAgLor primarily stores digital learning objects produced for agriculture, veterinary, food, environmental and forestry sciences as well as all other related basic and applied sciences such as biology, botany, zoology, genetics and bioinformatics etc.</p>	
---	--	---

2.10.4 LRE - LEARNING RESOURCE EXCHANGE

The Learning Resource Exchange (LRE) from the European Schoolnet (EUN) is a service that enables schools to find educational content from many different countries and providers. The evolution of the LRE has been supported by Ministries of Education in Europe and a number of European Commission funded projects such as ASPECT, CELEBRATE, CALIBRATE and MELT.

Anyone is allowed to browse content in the LRE repositories and teachers who register can also use LRE social tagging tools, rate LRE content, save their favourite resources and share [links](#) to these resources with the

2.10.5 TED – ED

The award-winning education platform that serves millions of teachers and students worldwide. URL: <https://ed.ted.com/Teachers Pay Teachers>

2.10.6 TEACHERS PAY TEACHERS (TPT)

A community of millions of educators who come together to share their work, their insights, and their inspiration with one another. TpT is an open marketplace where teachers share, sell, and buy original educational resources.

In order to support an effective search among the hundreds of learning elements, the authors have to fill out several metadata (like age group, subject, teaching goals, etc.) in accordance with the pedagogical aim of the content.

All Categories SEARCH Log In Join Us Cart

You Selected:

Grades
12th x

Prices
Free x

Sort by: Rating View: showing 1-52 of 14,996 results

- Grades**
- PreK
 - K
 - 1st
 - 2nd
 - 3rd
 - 4th
 - 5th
 - 6th
 - 7th
 - 8th
 - 9th
 - 10th
 - 11th
 - 12th
- Other
- Not Grade Specific
 - Higher Education
 - Adult Education
 - Homeschool
 - Staff
- Subjects**
- Arts & Music >
 - English Language Arts >
 - Foreign Language >
 - Holidays/Seasonal >
 - Math >
 - Science >
 - Social Studies - History >

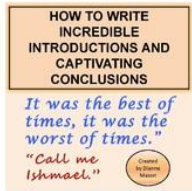

How to Write Incredible Introductions and Captivating Conclusions **FREE**

by Dianne Mason

165 ratings ★★★★★ 4.0

Digital Download PDF (352.39 KB)

When writing informational texts, students need to know how to introduce a topic and how to write a concluding statement that supports the information presented in the writing. This handout is

Subjects: Writing-Expository, English, Writing-Essays

Grades: 10th, 11th, 12th, Higher Education, Adult Education, Homeschool

Types: Handouts

+ Wish List

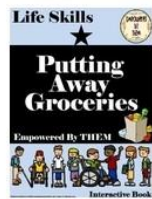

Putting Away Groceries Activity Book **FREE**

by Empowered By THEM

137 ratings ★★★★★ 4.0

Digital Download PDF (669.13 KB)

3 page activity book you can laminate and add velcro to showing where to put groceries away after shopping (refrigerator, freezer, or pantry). You can see one put together here:

Subjects: Special Education, Life Skills, Cooking

Grades: 9th, 10th, 11th, 12th, Adult Education

Types: Activities, Fun Stuff, Printables

+ Wish List



Tone Words in Categories! **FREE**

by Angie Kratzer

91 ratings ★★★★★ 4.0

Digital Download PDF (200.33 KB)

Do your students have trouble getting past "positive" and "negative" in describing tone? This 200-word tone list, grouped into categories, helps students with the nuance of tone. From sixth grade through AP

Subjects: English Language Arts, English, ELA Test Prep

Grades: 9th, 10th, 11th, 12th, Higher Education, Homeschool

Types: Handouts, Word Walls, Scaffolded Notes

+ Wish List



What is DNA and how does it work? - Animation **FREE**

2.10.7 TELU

TELU is a collection of free online micro-learning courses ("Micro-Lessons") designed to help busy educators use technology to support their teaching and learning.

2.10.8 OPEN PROFESSIONALS EDUCATION NETWORK

Another helpful guide when you look for an OER is the Open Professionals Education Network:



Looking for images on a given topic, you can choose Photo/Image Search to access a list of web pages to browse.



- [General Search](#)
- [Photo/Image Search](#)
- [Video Search](#)
- [Audio/Music Search](#)

2.3 Flickr



Flickr

2.4 Google Images



Google Images
Be sure to scroll down in adv
If you want content for comm

2.5 Pixabay



Pixabay
Note, that Pixabay images ar
the original author. While Pix
professional images Pixabay

2.6 Open Clip Art Library



Open Clip Art Library
Note, that Open Clip Art Libr
attribution to the original autl

The **Google Images** link guides you to a page where you can perform a detailed search, based on key words, image size, or even colour. You can try it by clicking on the picture below:



Advanced Image Search

Find images with...	To do this in the search box.
all these words: <input type="text"/>	Type the important words: winter hoarfrost
this exact word or phrase: <input type="text"/>	Put exact words in quotes: "frost flower"
any of these words: <input type="text"/>	Type OR between all the words you want: trees OR weeds OR grasses
none of these words: <input type="text"/>	Put a minus sign just before words that you don't want: -windows

Then narrow your results by...

image size: <input type="text" value="any size"/>	Find images in any size you need.
aspect ratio: <input type="text" value="any aspect ratio"/>	Specify the shape of images.
colours in the image: <input checked="" type="radio"/> any colour <input type="radio"/> full colour <input type="radio"/> black & white <input type="radio"/> transparent <input type="radio"/> this colour: <input style="width: 20px; height: 15px; background-color: red;" type="color"/>	Find images in your preferred colours.
type of image: <input type="text" value="any type"/>	Limit the kind of images that you find.
region: <input type="text" value="any region"/>	Find images published in a particular region.
site or domain: <input type="text"/>	Search one site (like sfmona.org) or limit your results to a domain like .edu, .org or .gov
SafeSearch: <input type="text" value="Show most relevant results"/>	Tell SafeSearch whether to filter sexually explicit content.
file type: <input type="text" value="any format"/>	Find images in the format that you prefer.
usage rights: <input type="text" value="not filtered by licence"/>	Find images that you are free to use.

[Advanced Search](#)

2.11 DIGITAL CONTENT CREATION

Today a large number of free ICT and Web 2.0 tools are available on the Internet.

They can be easy to use, most do not require high-level IT skills, and they can be well integrated into the learning process. Web 2.0 is a collection of online services that are primarily based on a community, where users collectively share content or share information with each other.

These online tools and teaching materials are not a substitute for traditional teaching methods but may be complementary to teaching activities. It is important to note that ICT tools are only of use if they help to improve the learning process.

Such tools include:

- Video and animation editors
- Social Media and Content Sharing (Image, Video Sharing) Personal websites (personal home pages)
- Collaborative Tools Virtual classroom Mindmaps
- Blogs
- Image resources

The Web 2.0 tools available on the Internet are many. In the following sections we'll show you some easy-to-use apps.



2.12 TOOLS FOR CREATING DIFFERENT TYPES OF EDUCATIONAL VIDEOS

For teachers, mastering a new method of teaching is always accompanied by many planning and reasoning activities.

Breaking away from old habits, and trying something completely new means leaving one's comfort zone. Additionally, students are not always enthusiastic about changes either!

However as teachers, parents and in the past as students we have all often felt an intrinsic need for change of pedagogical thinking, in the processes of teaching & learning, and in the theory of teaching (didactics). It is necessary to constantly analyse and recreate our frameworks for teaching, by considering new aspects or assessing ones that have been ignored for a long time

Technology can be of great use in this change. For example, the production and use of a video can expand possibilities. We can insert [links](#), and add extra literature for those students who would like to deal with the subject in more detail. We can bring the subject closer to the expectations of today's students with visual and [hypertext](#) thinking through use of images and animations in our explanations. With some editing tools, we can readily integrate self-checking questions directly into the video.

Video production is as simple today as preparing a presentation, and it is worth learning how to do so.

2.12.1 PREPARATION

Having selected the appropriate learning content, prepare a script. This will pay dividends.

In it, note down what the video should show and how things should be explained. The script need not be followed prescriptively, but thinking over the process beforehand will make the job easier. In a manner similar to planning a lesson, plan how much time will be dedicated to the different sections in the video and consider what other supplementary materials (images, ready-made videos, e.g. for experiments in Physics or Chemistry, infographics, diagrams etc.) might be needed.

Collect and prepare supplementary materials, as this work will make the overall task easier and the time taken to produce the video shortened.

Making a video for the first time and with limited experience can be a lengthy process. All preparation can result in significant time savings, so it is worth taking the planning and preparation stage seriously.

In this section some useful applications are presented in detail. They make it possible for anyone to create attractive animations and videos without any specific prior knowledge.

2.12.2 TURNING IMAGES INTO VIDEO IN MINUTES - ANIMOTO

Animoto is used to create "slideshow videos". You may search for free images on the net, but you can also upload your own images or videos, into which you can insert music, etc.



2.12.3 ATTRACTIVE PRESENTATION – SWAY

Sway is a new, free app within Microsoft Office with can be used to readily create interactive reports, personal stories, newsletters and presentations. These may be created with or without pre-defined templates, so any work can be made to look unique. Importantly, users need not be designers to create interactive, attractive presentations.

With Sway it does not take long to create a colourful presentation that can easily be shared without registering or downloading anything. The program is free with a Microsoft Account, and more design elements and content types are accessible if it is used as part of an Office 365 subscription.

To start using it, register at: <https://sway.com/>

The following tutorial is one among the many available on the Internet.



2.12.4 PEDAGOGICAL APPLICATIONS

Using Sway, a simple Power Point presentation that might be considered boring by students can be made more interesting, colourful and interactive, as well as potentially saving potential preparation time.

Even **students can master** its usage, so it can be used as a mechanism for checking how well they have mastered the learning material, i.e. ask them to create Sway presentations of their own on a specific topic.

2.12.5 SIMPLE VIDEO MAKER – BITEABLE



2.12.6 AWESOME VIDEOS – POWTOON

This [online](http://www.powtoon.com/) application, accessible at: <http://www.powtoon.com/>, makes it easy create animations for any subject.

Short animations can help to **motivate** students, raising their interest in a specific topic. It is generally well-known that the content of a message greatly influences how easy it is to remember it.

If we match visuals – images, illustrations, or even simple icons - to our thoughts, it helps make memorizing and the processing of information much easier as our **visual memory** is stronger. We are less effective in recalling speech or written text.

Animation is much more than showing images one after the other, and is very suitable for visual storytelling.

Students understand such messages more easily and they are increasingly likely to react positively to a more human way of transferring messages. Stories activate the brain, so they will not only understand, but will be able to "experience" the learning material by holding their attention.

The process of creating an animation consists of five steps: (i) planning, (ii) adding the soundtrack, (iii) adding visuals, (iv) checking, and (v) publishing.

The following tutorials will hopefully help with mastering the usage of this really useful application:

<https://www.powtoon.com/tutorials/>

2.12.7 SCREEN VIDEO - SCREENCAST-O-MATIC

There are several free applications that are suitable for capturing a screen: Screencast-o-matic is a useful one.

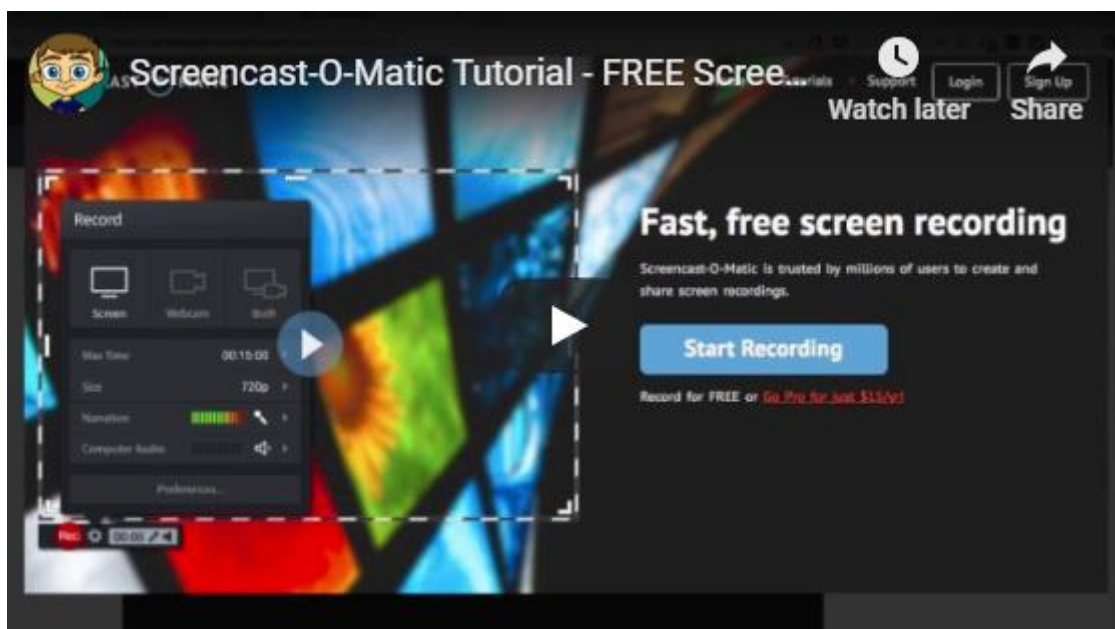

2.12.8 VIDEO EDITOR - OPENSHOT

This [free software](#) is easy to use and comes in handy when you want to create a new video by cutting other videos, inserting soundtracks etc.



2.12.9 MAKING VIDEOS INTERACTIVE WITH H5P

With the help of [h5p](#) you can insert several types of interactive elements (such as quiz questions) into a video, and much more ...

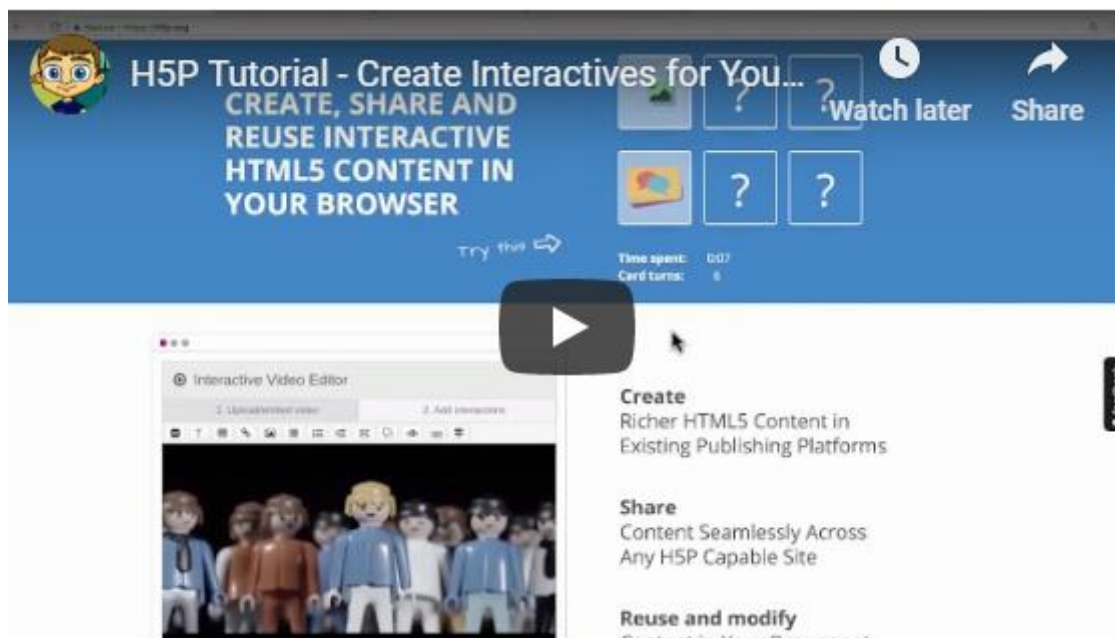

2.13 COLLABORATIVE LEARNING WITH CONCEPT MAPS

Thought maps, mind maps, or concept maps can be created for different reasons.

They can be used for brainstorming a project, or - with respect to a particular subject - they can be a great way to produce a summary from which to learn about a topic. They can even be used in conjunction with a video.

When creating a mind map [online](#), the procedure is the same as that used on paper. You pick a primary concept, add connected concept categories, and continue to add subcategories. The difference comes with the flexibility of [online](#) format. The 'workspace' is infinite, but can be quickly navigated with spaces between swapped between concepts if we change our mind. Compare this with having to redraw on paper!

In the [bubbl.us](#) system we can readily add colours and sizes to categories, helping to reinforce the implicit connection between thoughts. In addition to hierarchical relations we can also highlight different types of connections. For example using different arrows between concepts to indicate connections which are not obvious [links](#).

This program gives us an opportunity to develop a visual construction of a mind map without registration. layouts can be readily changed by the click of a button, and also we can attach [links](#) to concepts. Attaching pictures is also possible, but this is a premium-only feature. After finishing we can share a completed map or download it in picture format. If you register then you can log in and save it for later use or redevelopment.

2.13.1 PEDAGOGICAL USE

Concept maps fit well with the preparation of flipped classroom lessons, and of videos and their processing. We can make a map about our plans and connections, or to plan the steps of a flipped lesson. We can use maps for brainstorming, and can make maps to help to organize the materials for a video. They are useful as a 'starting point' and overall picture to help the processing.

Concept maps can also act as an error checking interface. In flipped classrooms, for example, they can be used with videos with an attached 'term list'. Students can then be asked to collect the definitions of the terms in the list from the video, or even in class, and [link](#) them together as a concept map.

From the resulting map teachers can see how much the student has understood from the video, or even if they have watched the video. For further ideas visit <http://www.mindmapping.com/>. You may also try an alternative free mind mapping tool: [mindmeister.com](#)

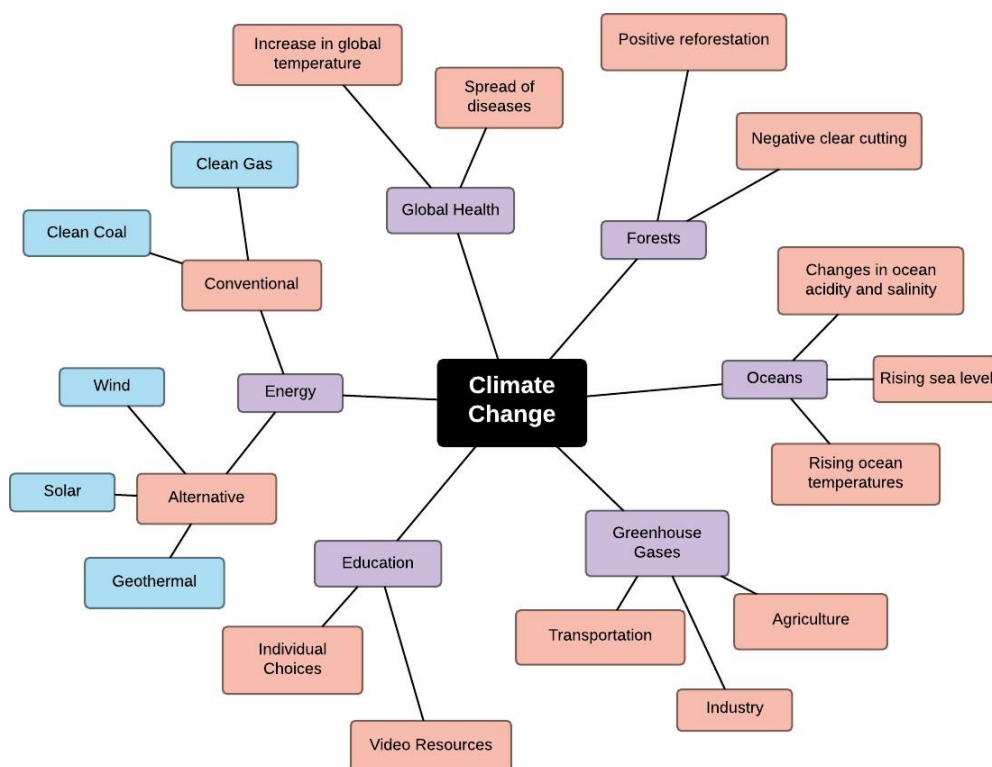

Figure 7: Climate change mind map (Image source: Lucidchart)

2.14 PRACTICING ONLINE – LEARNINGAPPS

At the **LearningApps** (www.learningapps.org) page you can find various tools (so called blocks) that can help to motivate students to watch a video, or to process information covered in a video.

The page offers customizable games that help with understanding, memorizing, or checking the mastery of the learning material. You have the opportunity to create matching activities, crosswords, word searches, etc. You can also pause videos to insert questions or games within it, all of which helps to maintain motivation, attention, and even understanding.

If you want to make many such blocks for a topic, it is advisable to arrange them in a matrix so that students find everything in one place that relates to that topic.

Here is an example for a matrix prepared for students studying the topic of the human brain: <https://learningapps.org/display?v=piema7guj16>.

Students can also create blocks for themselves - a useful exercise that helps to deepen their knowledge of a topic.

A major benefit of the example page above is that the teacher does not need to produce all content them self. Collections can be built up, tagged and saved as public blocks from which it is relatively easy to create a platform for students to practice a given topic.

After logging in, the page works as a virtual classroom, so if you do not currently have a content sharing application, you can use this platform for your flipped lessons.

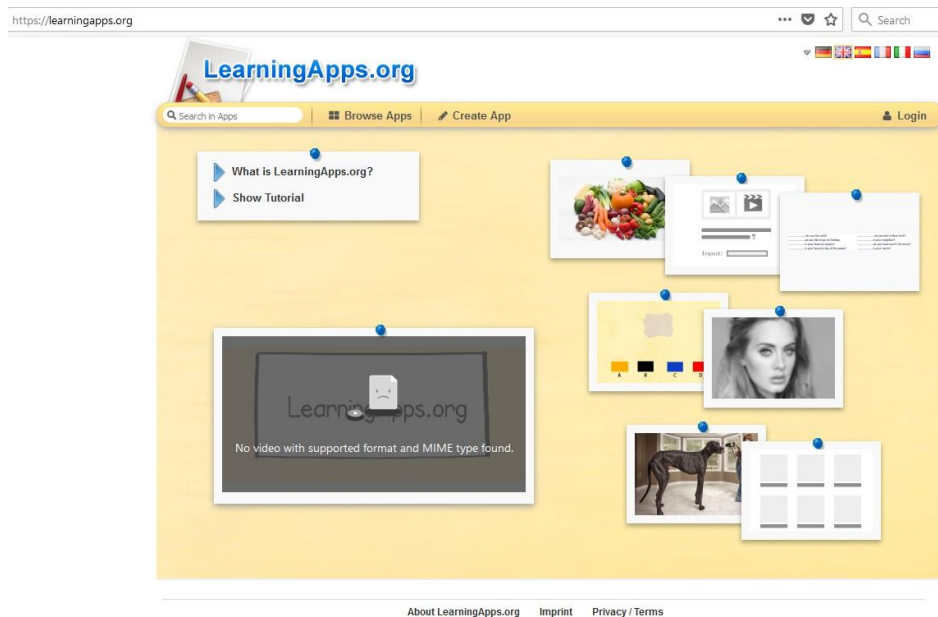

2.15 SOCIAL MEDIA IN TEACHING

2.15.1 SYMBALOO

Symbaloo, a digital bookmark, is a good place to start looking at social media and we will refer to it as a starting point. The 'webmix' prepared here will serve as a fast access starting point to other applications.

In a similar fashion to that of the tiles in Windows, Symbaloo stores its collection of links in visual form. It is accessible at <http://www.symbaloo.com>, where an example of this 'webmix' is presented along with information about the program and the first steps for use. After login you can begin to create a webmix immediately.

The program is a digital bookmark, so you can collect and organize all your useful web pages into one topic, and then access them with a single click. So, for example, you can create a 'webmix' related to the Flipped Classroom model, where you save links to videos and articles about the flipped method, interesting facts, etc. You can create your own webmix but you can also share them like this: <http://www.symbaloo.com/mix/fc-ikteszkozok>

This was a webmix prepared to enable quick access to applications presented in this module. Clicking on "update webmix" will ensure you are seeing the latest version, and allow you to make edits and additions or to delete links. If comments are enabled you can make such changes based on the comments of the students.

On the top navigation bar you can find the 'Share' icon.

Before being able to send a webmix to your students, or to make it public, you have to 'approve' your webmix to make it visible within the internal gallery of Symbaloo. If you approve it, you will get a web address allowing

your webmix to be shared on Facebook, Twitter or whatever social media system you make use of.

You can give a name to your new webmix, and by clicking 'Add' you can start editing. The middle section of the webmix is fixed - it is a Google browser, where you can set various filters (maps, images, etc.) and you can browse among your webmix files or even among other users webmixes.

When on an empty tile, clicking on 'Create' allows you to define the URL (web address) of a web page you want to add.

You can specify whether that page should be opened in a separate page or embedded (for example to watch a video).

If the system knows of the webpage, it automatically offers a logo and a name for it. However, you can edit both, and have the name appear on the tile as well. You can modify the background colour, and even add a new logo or edit the existing one. You can either choose an icon for the logo, or upload a picture from your computer. Once all settings are complete you can 'Save' the tile.

Be careful: there is no auto-save here so be sure to click on the Save button.

If you don't know exactly which web pages you want to use when collecting materials for a given topic, you can use the Search and Browse functions. When searching, you have to provide a keyword, and the program will offer related tiles from existing public webmixes. However in the Browse function you have to choose a category first, and then browse among the tiles to select the ones you want to attach to your own webmix.



Figure 8: Symbaloo tutorial

PEDAGOGICAL APPLICATIONS

You can make your job that bit easier by being organized, and this program is a very useful tool to do exactly that.

You can create separate webmixes for your various subjects, and organize all related web sites and pages. This way you have everything in one place and can easily access all things that connect to the topics in question - articles, YouTube videos, blogs, events, etc.

The program offers unlimited possibilities for your students as well. You can share all collections with them, but you can also assign students tasks, for example investigating the internet and collecting web pages relevant to the topic under discussion. A webmix prepared for students helps them to develop a clear overview about what is relevant to a topic. If your students have their own personal web pages or blogs, vlogs, Symbaloo allows them to collate everything in one place to be accessed by a single click.

The program also acts as a visual organizer. Tiles can be customized, which helps with understanding their relationships and structure, shows their connections, and gives a clear overview. The webmix related to this current module is set up to do exactly that. On the left hand side there are applications similar to Symbaloo, but with more functionality (evaluations, setting rules, etc.). There are applications for generating ideas and brainstorming, and across the top there are programs used to create videos.

At the bottom there are applications that can be used during video making but usable by students when processing the learning content. On the right hand side there are websites that make watching a video more interesting, or help with class activities related to processing a video.

Applications with a red background are those that will be covered in later sections of this module. In the absence of Moodle or other virtual classroom, you can make use of this system for sharing content.

2.15.2 PINTEREST

On the left side of the webmix starting point there is a collection of applications that can also be used for idea collection and ordering, but but also for functions more than just bookmarking.

An application similar to Symbaloo is Pinterest - a social site used to save and organize selected websites 'pinned' onto thematic tables.

The most important difference between Pinterest and Symbaloo is that while the latter makes it possible to save web page for the subject (by using titles and labels to indicate the exact direction of navigation after opening), Pinterest records this together with an image which makes it visually easier to search and systemize. For example, if you are working on a cooking or decorating task with your students, it is more appropriate to choose Pinterest for your collection because it can readily manage the collection with a few clicks to save the recipes and ideas, but it can also add images and subtitles for clarity.

To save your ideas and websites, first register with the system.

At www.pinterest.hu first you need to supply your e-mail address and give a password, followed by some minimal additional information (username, gender, age). You can also register as an organisation if that is more appropriate. E-mail registration is two-step, it is necessary to validate the registration also by e-mail. If you wish to skip this process, you can access the application through other social sites (e.g. Facebook).

After registering and logging in you are offered help. You are also given the opportunity to choose from your areas of interest or to search to find the sides you would like to study.

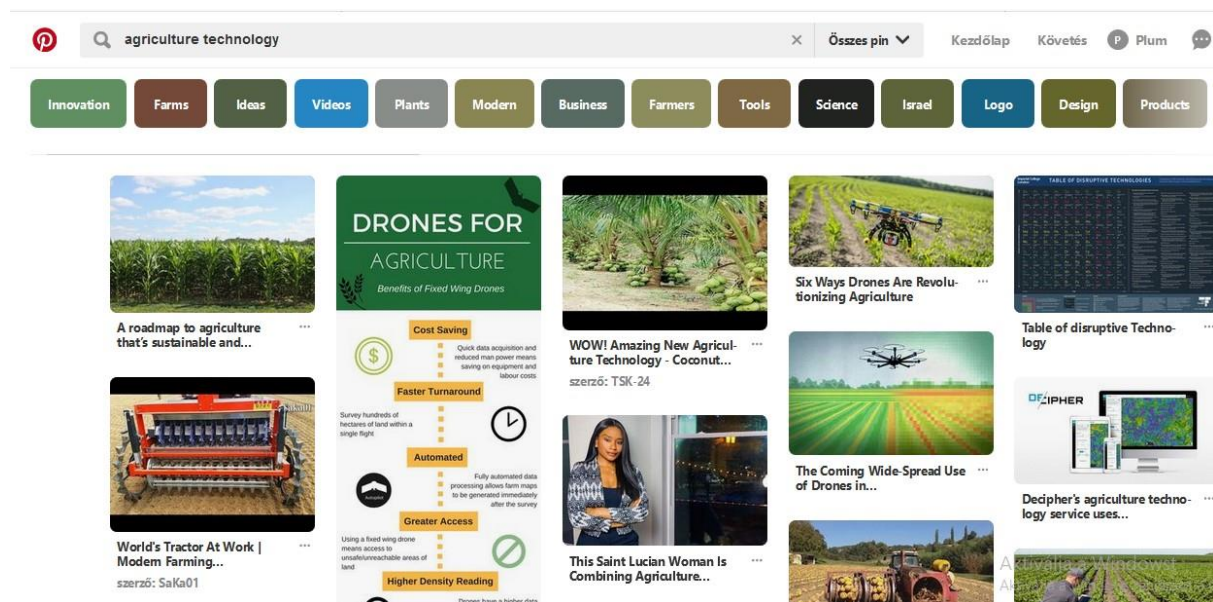

Pinterest can be used in these cases when you want to save visual elements grouped around a topic. Even if you are simply collecting images for a particular lesson or subject, or just wanting to prepare visual works (e.g. infographics) for your students, Pinterest can make your work that bit easier.

You can also set tasks for your students that that require them to collect materials about a topic.

Similar to Symbaloo, you can also use Pinterest as a virtual classroom. Tables can be set to be available to students for a particular class or activity. Material stored on Pinterest can be added to. If you upload a video to the table (e.g. through Youtube), then you can add task to the table in the classroom, or add content through collaborative work.

2.15.3 ONLINE NOTICE BOARD - LINOIT

This program provides several functions that help with the organization of brainstorming sessions, or discussions of ideas and evaluations in the classroom.

LinoIt can be considered as a 'cork board'. The program can be used without registration, but the registration process doesn't take much time and is worth doing. Once in the application you are presented with an organizer interface where you can check the various 'canvases' you might use.

You can see the tasks marked for use and can check your groups for activities. In the menu bar at the top right corner you can modify your settings by clicking on 'Preferences', and set parameters such as username, password, profile image, time zone, or the language of the application.

There are also various searching options on the menu bar.

Canvases created by yourself are found in the 'My canvases' section, and you can always create a new one here by clicking "create a new canvas".

The new screen should be first customized with a name and a background - anything from cork board or, if you do not like any of the options, an image uploaded from your computer. You also need to fix the visibility settings of the canvas, choosing from the following three options: (i) for personal use only, (ii) anyone may see the notes, or (iii) anyone may pin a new note onto the canvas.

Settings can always be changed at a later time.

If you wish your students to be able to post to the canvas, then it is recommended to create a group and put the canvas within the group (this will be discussed later). Finally, you can agree to share your canvas among others recommended by Lino. You can set an e-mail posting, and create an RSS for your canvases. To save settings click on "create canvas".

On loading a canvas, you are presented with a large work surface.

The lower left corner of the screen shows the main menu and offers the option to navigate to previous canvases. If the menu bar is in the way, it can be minimized and re-opened if and when necessary. The 'notes' at the upper right corner are the key to operating the program. Through these you can express opinions and arguments, adding text, image, or even video to ideas, etc. To edit any text, you can use the working surface in many ways, and choose icons to differentiate or colour any notes. On a shared surface, an unlimited number of users are allowed to work simultaneously thus enabling the students to comment quickly and anonymously when providing feedback, opinion, and ideas.

LinoIt is excellent for online collaboration among students.

Similar to the collation systems presented earlier, you can use its pages as simple digital bookmarks, but extend this with the potential of adding text beside the links, e.g. for those who are cooperating with us or visiting our cork board.

The collecting board allows you to launch a brainstorming session around a topic, or to encourage your newly-formed group to create rules (which can be recorded for later use). Your groups and/or your collaborating students can produce introductory photos and videos that can also be uploaded to a 'note'. The number of options is infinite

Surfaces are often used in classes for project or group assessment. For example, a teacher may start by making notes, or presenting some questions relating to an evaluation, or even add their own responses (on separated notes). This can be shared with the students who are asked to do the same. A useful attribute of the system is that it maintains the anonymity of the posters, though there are ways to know who created a post!

Lino's visualization options are many, and it can also be used as for producing mind maps. For example, when making a video you can add reminders for your to focus on. You can collect sample-videos, tutorials, or use the tables to sketch a summary of the topic that can be incorporated into the video tutorial.

You can request a feedback from Lino about the video. You can add question that students are expected to answer after watching the video. It is recommended not to set factual or data questions but to use open questions that solicit opinions and thoughts. A particular advantage of such as video is that students can do all this without registration, as you can share an e-mail code with them and their response will automatically be posted as notes onto the canvas.

2.16 PUBLISHING DIGITAL CONTENT

The preparation of digital learning content (videos, presentations, etc.) is only the first step in using digital tools in teaching.

The next step is to know **how to share** this content with students. There are many ways to do this, but most of them belong to the group of [web 2.0](#) applications.

2.16.1 SOCIAL SOFTWARE, CONTENT SHARING SITES

"No one knows everything, everyone knows something, all knowledge resides in humanity" (Pierre Levy)

Social software is at the heart of [web 2.0](#). These applications turn the Internet into a platform of common creation, collaboration and communication.

It is instructive to draw up, and maintain, a list of [web](#)-based programs that encourage us to participate in virtual communities, publish materials, share thoughts in videos, documents, images, mind-maps, etc., and in doing so leaving a footprint in the form of digital messages. Examples of social software include **YouTube, Flickr, Picasa, Animoto, Prezi**, etc., though most [web 2.0](#) applications belong to this category.

They all operate in a similar way from a technical point of view. The application runs on a central [server](#), allowing registered visitors to upload, edit, create their own objects (mind-maps, videós, images etc.) - usually providing some description of the object in the process. Users can decide to share the content they create, or to keep it private. Non-registered guests can generally browse public content, though sometimes search is only allowed if a user first registers.

In preparing content on these social platforms it is normal to **send a link** to students so that they can access it without necessarily having to enter the website explicitly.

There is a great advantage in having a **permanent website** where you can collect useful learning materials, and to act as a reference point for students to share and learn from. Here are two [web 2.0](#) applications that offer such as service.

2.16.2 SHARING VIDEOS

Earlier we saw applications that could be used to create videos for a website. These applications included Animoto, Sway and Powtoon. In these systems once we created our videos we just needed to provide the [link](#) for our students to be able to access them.

If you do your own video recording (with some editing, cutting on your computer), then once ready you can upload the results to YouTube - following after a few simple steps. As YouTube is owned by Google, you will need a Google account to log in.

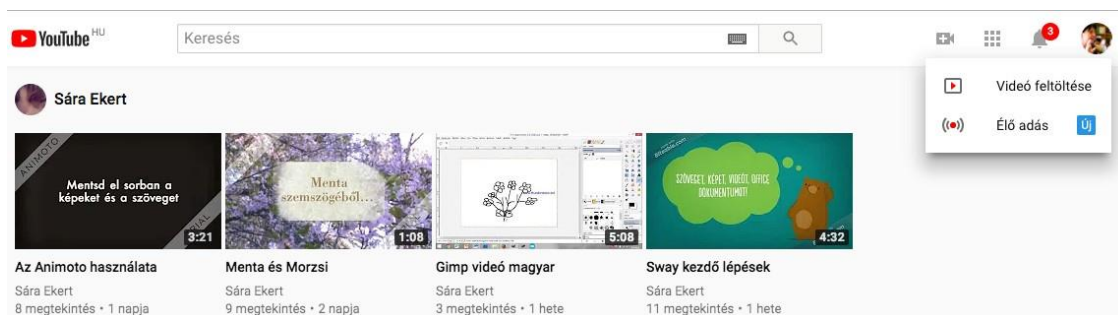

In the right-hand corner click on the small cross: the "Upload video" text appears taking you to the upload platform.

Click on the following link to look at the upload steps:

<https://support.google.com/youtube/answer/57407?co=GENIE.Platform%3DDesktop&hl=en>.

[Links](#) that are too long are impractical, and contain all kinds of characters. **Bitly** (<https://bitly.com/>) shortens [links](#), thus making them friendlier to use.

This is a long [link](#), so it can be shortened: <http://bit.ly/2fAb3MR>

2.16.3 SHARING PRESENTATIONS – SLIDESHARE

The screenshot shows the SlideShare website interface. At the top, there is a search bar with 'smart farming' entered. Below the search bar, there are navigation links for 'Home', 'Explore', 'Presentation Courses', 'PowerPoint Courses', and 'by LinkedIn Learning'. There are also buttons for 'Upload', 'Login', and 'Signup'. The main content area displays a grid of presentation thumbnails. The first row includes three presentations: 'SMART FARMING' by Raj Patel, 'Smart and affordable farming solutions for Africa' by Brussels Briefings, and 'Big Data and Smart Farming' by Sjaak Wolfert. The second row includes 'Development of Smart Farming (based on Arduino)', 'Smart Farming et Big Data en Région Wallonne' by LIÈGE université SPHERES and A lion campus, and 'Agri-IoT: A semantic framework for IoT-enabled Smart Farming Applications' by P-SPHERE URB and Insight.

Slideshare is a content sharing website where, via the *Explore* menu, you can browse among presentations uploaded by others, and even *Search* for specific topics.

At <https://www.slideshare.net/> click on the *Upload* button, and a window appears, where you can "drag and drop" the presentation to be shared, or alternatively select the file from your computer.

If you have not registered here before, you can do so with an existing [LinkedIn](#) account. If you do not have one you can create a new account with the *Signup for an account* button.

Once you have uploaded a presentation, click on *Share* to get an embed code. This can be used on your own website to provide access for students, or it can simply be copied and sent to students directly.

2.16.4 PERSONAL WEB PAGES

Another group of [web 2.0](#) tools are useful for creating personal [web](#) pages, They offer many services, including RSS² feeds which are very useful for customize your own starting pages.

² RSS is a program made for users that checks for [web](#) page – in our case the canvas – and sends information to users if any changes have been made to it. With RSS it is not necessary to continually check pages from time to time. Changes are pushed out when they happen.

Examples of the available 'widgets' include:

- diary and clock
- collection of links to websites (without RSS service) editing and presenting notes or messages calculator
- access to own mailboxes and email simple games
- invitations, etc.

Web 2.0. tools suitable for creating personal web pages with RSS feed include: *Netvibes*, *iGoogle*, *Protopage*, a *Pageflake*, *MyYahoo*, *Microsoft Live* portals.

Protopage is a personal web page, accessible from a PC, tablet or phone. It is useful for collecting relevant news, favourite blogs, bookmarks, reminders and many other things - all in one place. It provides a set of functional 'widgets' that make it easy to subscribe to relevant RSS feeds.

2.16.5 BLOGGING

A blog is basically a website used for publishing diary-style entries.

There are different types of blogs, including **Personal blogs** - where we find posts related to a specific person - which are very popular, but it is common to find **thematic blogs** that contain posts related to a specific topic.

The **microblog** service offers a communication portal to users suitable for exchanging short messages regularly and quickly. Its social function is important also as it is possible to follow posts from friends or people dealing with topics we are interested in.

Blog portals tend to be easy to use, with basic ICT skills being sufficient to create blogs. For example, try out Google Blogger at the following link: www.blogger.com

2.16.6 VIRTUAL CLASSROOM

One huge benefit of **Google Classroom** is that it is available in local languages. The following tutorial shows how it can be used.



Another popular application is **Edmodo**.



Edmodo

Join a Group Login

Teach More. Learn More.

Millions of teachers use Edmodo to engage students, connect with other teachers, and involve parents.

Create your free account

I'm a Teacher I'm a Student I'm a Parent

Focus on teaching, not paperwork.

With intuitive features and unlimited storage, quickly create groups, assign homework, schedule quizzes, manage progress, and more. With everything on one platform, Edmodo is designed to give you complete control over your digital classroom.

3 21ST CENTURY PEDAGOGY

Our society today needs young people who are flexible, creative, and proactive – young people who can solve problems, make decisions, think critically, communicate ideas effectively and work efficiently within teams and groups.

Simply 'knowing knowledge' is no longer enough to succeed in the increasingly complex, fluid, and rapidly evolving world in which we live. In order to optimise life-long learning and potential success it is now widely accepted that young people need to be given opportunities to develop personal capabilities and effective thinking skills as part of their well-rounded education. (Source: [Active learning and teaching methodes, Page1](#)). This implies the need for a more student-centered teaching and learning approach.

Student-centered teaching and learning is based on constructivist learning theory, where learners are active in how they interpret information and in building meaning and knowledge through prior experiences by using observation, problem-solving and processing (Cooper, 1993; Wilson, 1997; Ertmer & Newby, 1993).

The table in the figure below highlights the key differences between students as passive learners (the traditional norm) and having students involved in a more active learning environment:

Characteristics of **Passive** & **Active** Learners

	Passive	Active
Class lectures	Write down what the Instructor says	Decide what is important to write down
Textbook	Read	Read, think, ask questions, try to connect ideas
Assignments, Studying	Reread	Make outlines and study sheets, look for trends and patterns.
Writing, Class Assignments	Carefully follows the professor's instructions	Try to discover the significance of the assignment; look for the principles and concepts it illustrates
Writing term papers	Do what is expected to get a good grade	Try to expand your knowledge and experience with a topic and connect it to the course objective or content

Source: Study and Critical Thinking Skills in College, McWhorther, K.T., 1996. p. 14.

In the following sections, we will learn about some important active learning methods and possibilities.

3.1 PROJECT-BASED LEARNING

'Education is not preparation for life; education is life itself. (Dewey)

Real-world issues motivate students. Project-Based Learning (PBL) is a teaching method in which students gain knowledge and skills by investigating and responding to an engaging question, problem or challenge.

Projects usually start with a problem-initiating, introductory question that motivates students to explore, research, discuss, and collaborate to present their conclusions to a real audience.

PBL applies across disciplines and consistently emphasises active, student-directed learning. PBL gives students an authentic, real-world context for learning, creating a reason for learning to occur. PBL also offers students choice and voice, personalising the learning experience either through their products or in the design process. Students face complex challenges when they complete their formal education; knowing how to solve problems, work collaboratively, and think innovatively are becoming essential skills - not only for their future careers but also for tackling difficult issues in local communities and around the world. (Source: <https://www.edutopia.org/project-based-learning-student-motivation>)

3.1.1 A PROJECT-BASED LEARNING FREE ONLINE COURSE

Within the [Intel® Teach program](#), a [Project-based learning](#) curriculum for teachers was completed.

Project-based approaches are still less widely known and used in education in many countries. Throughout the interactive course, teachers can deepen their understanding through a number of examples and tasks to get to know the new method:

- learn the knowledge needed to design PBL projects,
- learn how individual performance can be measured in projects,
- learn how to guide the learning process during the duration of the projects;
- learn how to develop their students' 21st century skills - such as co-operation, self-management, critical thinking, and information literacy.

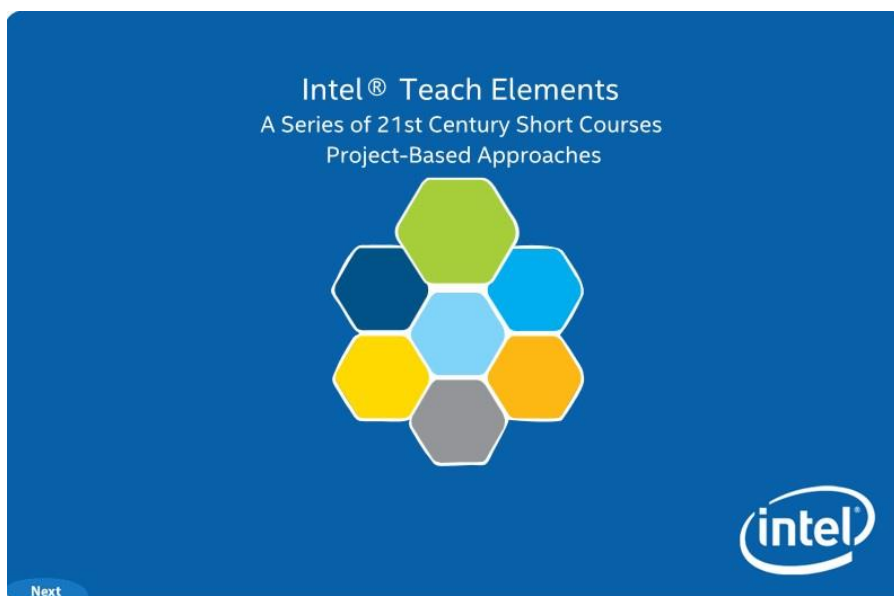

Although the preparation and design of a project requires more work from teachers, research shows that project work is effective for students. In many cases, students are also learning more enthusiastically, where they might have previously been difficult to motivate. The new learning method also develops students' skills given less emphasized in traditional learning (e.g. communication and co-operation, leadership skills, and responsibility).

Training is available free of charge [online](#). It is recommended to all teachers who would like to try out a new method for raising students' interest and developing their 21st century skills.

The Project Based Learning course consists of the following five modules:

- Projects Overview
- Project Design
- Assessment
- Project Planning
- Guiding Learning

Concept and other features of the project-based learning course include:

- everyday tasks and problem solving, research,
- group work, cooperation,
- self-evaluation and evaluation of each other's work, self-management,
- learning reflections,
- education at external locations, involving experts, volunteers,
- presenting project results to the audience.

3.1.2 RESEARCH-BASED LEARNING

Research-based learning builds on students' curiosity and motivation. It is an educational method that models scientific research.

Students need to solve a real-life problem, form groups, ask questions, and find answers to these questions. Students build on their own knowledge based on information available from sources.

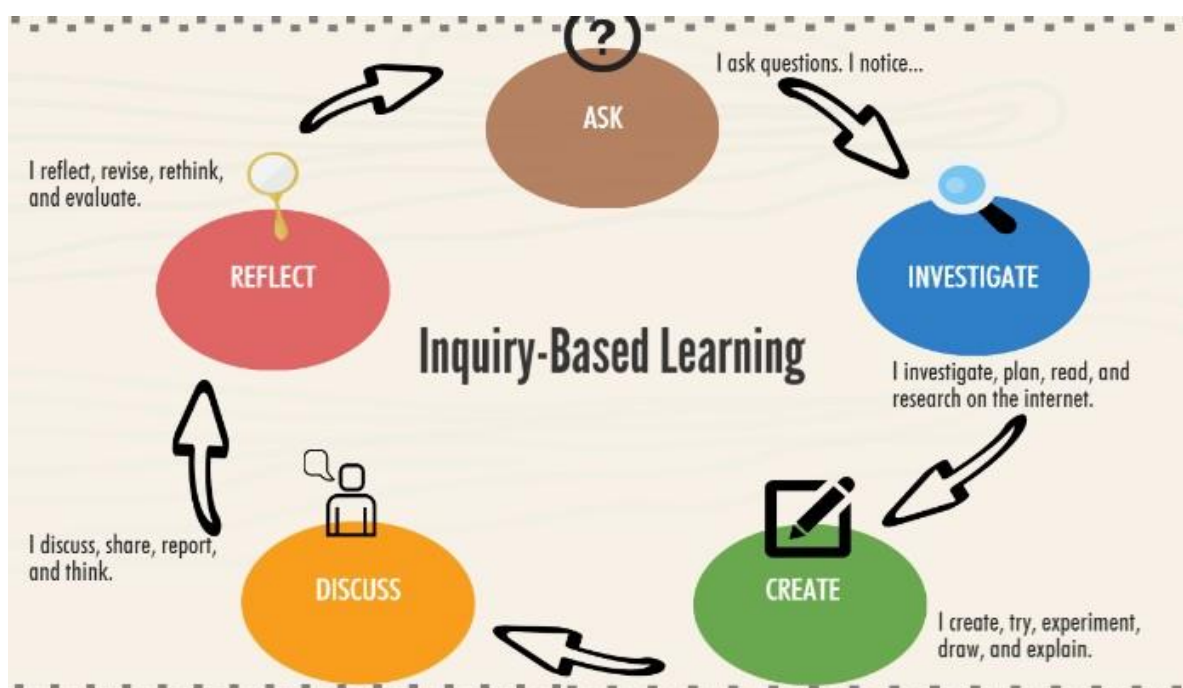

Figure 9: Inquiry Based Research Process (Image source: Atlas)

The basic steps of research-based learning are:

1. To formulate a question or a series of question related to the research topic. This question is also called hypothesis or problem statement.
2. After asking the question, students are encouraged to explore the topic by gathering information from different sources and start research.
3. If students have gathered enough information, they should sort them into categories or sketch the data highlighting important information related to the topic.
4. In order to develop a better understanding of the topic, discuss and analyse the information. The teacher can also direct the discussion and highlight the conclusions of the research work and show how they relate to solving the initial problem
5. Conclusions should be drawn up and re-addressed with respect to the original questions. Student reflections are very important, through which students can compare research results and conclusions with the original questions and list the steps that led to the conclusion.

Advantages of research-based learning:

- Students can control their own learning, in the same way as scientific research works in reality.
- Students are able to identify their own research areas and participate in a practice-oriented learning, where they seek information through scientific research methods.
- This method increases the student's commitment to learning and enhanced critical thinking skills, while creating a culture that evaluates students' own ideas.

3.1.3 PROBLEM-BASED LEARNING

Problem-based learning (PBL) is a student-centred approach.

To start PBL, students are given real life problems then work in groups, trying to understand the problem, gather ideas and look for solutions. In traditional teaching, students would be first taught from pre-determined curricula, then use their knowledge to solve problems. In this PBL method the problem is the start and focus of the learning process, which encourages motivation and learning.

Why use problem-based learning?

- Working in teams.
- Managing projects and holding leadership roles. Oral and written communication.
- Self-awareness and evaluation of group processes. Working independently.
- Critical thinking and analysis. Explaining concepts.
- Self-directed learning.
- Applying course content to real world examples. Researching and information literacy.
- Problem solving across disciplines.

Useful links to learn about Problem-based learning (PBL): Nilson (2010, p. 190) lists the benefits of problem-based learning. A well-designed problem-based project develops the following skills of the students:

- Working in teams.
- Managing projects and holding leadership roles. Oral and written communication.
- Self-awareness and evaluation of group processes. Working independently.
- Critical thinking and analysis. Explaining concepts.
- Self-directed learning.
- Applying course content to real world examples. Researching and information literacy.
- Problem solving across disciplines.

Useful links to learn about Problem-based learning (PBL):

<https://www.maastrichtuniversity.nl/education/why-um/problem-based-learning>

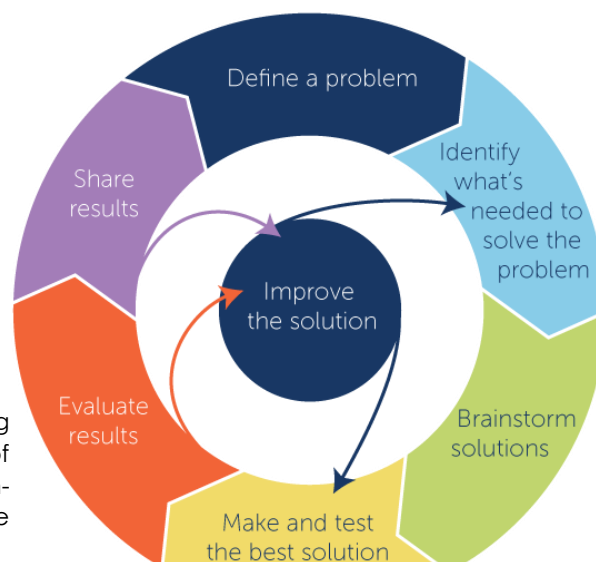

Figure 10: Problem-based learning (Image source: Advancement Courses)

3.2 FLIPPED CLASSROOM

The Flipped Classroom (FC) is a **student-centred** model aimed at increasing student engagement, understanding and retention by reversing the traditional classroom teaching approach.

There are a number of existing definitions for the FC, most of which vary only slightly, but the Flipped Classroom is basically a more student-centered approach to learning whereby **students receive lecture**

materials before class, generally in some digital format, which they should then study before taking part in discussions about their learning in class.

This approach allows students to learn about the topics **outside** of class and at their own pace. Then they can come to class already informed and prepared to engage in discussions on the topic. In this way they can apply the knowledge they have gained through active learning, spending their class time undertaking more active and collaborative activities. In applying this model, a more efficient use of class time is anticipated by focusing on the practical application of knowledge during class.

Regular and structured use of technology in this more student-centred approach is what can differentiate the flipped classroom from a regular classroom where additional, supplementary resources are used.

Though there is a familiar feel to this model, it is not necessarily straight forward to adopt and apply a Flipped Classroom method - though it is not necessarily difficult either. There is a necessity to think about teaching and learning strategies, to consider the learners, their abilities and learning preferences, and the materials needed to support an implementation.

The success of the Flipped Classroom depends on how well the content being studied aligns with the topics of the course. The teacher must ensure that his/her students can study and become familiar with what has to be learned and accomplished before, during and after the class.

An effective and successful flipped classroom needs careful preparation, and well-informed lesson planning. The normal requirements for lesson plans apply equally, if not more so, when applied to Flipped Classroom lessons.

Teachers have to plan their own activities, as well as their students' activities, for three distinct phases (see above):

1. before the class
2. during the class
3. after the class.

Before class:

students learn at own pace:

- ✓ watch video at any time of the day 🕒
- ✓ as many times as needed ⏮ ⏭
- ✓ note down questions or key concepts 📝
- ✓ no more frustration with homework 😊
- ✓ if absent, can catch up fast



teachers create content:

- ✓ supported by technology
- ✓ good tool for motivating students
- ✓ can be re-used
- ✓ if absent, can still deliver the lesson



In the classroom:

Active learning



students

- ✓ apply new knowledge
- ✓ ask questions and get immediate answers
- ✓ better understanding



the teacher

- ✓ can really differentiate
- ✓ decides how much time to spend with each student
- ✓ better classroom management

- ✓ increased interaction (student-teacher, student-student)

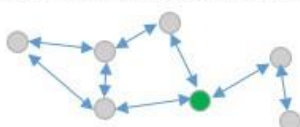

win-win situation

- ✓ students have more control over their own learning process
- ✓ higher order skills are developed
- ✓ better results
- ✓ transparency for parents.

If you are interested in following up on further details of the flipped classroom method, you can download a book (in English or Spanish) on the overall methodology and its application from the following [link](#):

[Flipped Classroom in Practice - http://flip-it.hu](http://flip-it.hu)

3.3 GAMIFICATION IN EDUCATION

Nowadays, it is often said "make learning fun", to better involve students in learning.

Several educational games appeared, and there could be a long argue about their advantages and disadvantages. However, a high-quality educational game is a constructive learning technique, that increases the motivation and engagement of students, provides useful information, identifies real problems that students need to find a solution and teaches students how to think.

Below we present two agricultural-related games.

These games are in English, so besides agricultural knowledge students can also practice English agricultural terms.

3.3.1 JOURNEY 2050

[Journey 2050](#) is a FREE agriculture education program that challenges participants to answer the question: "How can we sustainably feed 9 billion people by the year 2050?"

Journey 2050 takes students into a virtual farm simulation that explores world food sustainability.



Using an inquiry based approach, the program encourages students to make decisions and adjust them as they see their impact on society, the environment and the economy at a local and global scale. The students hear from farmers across the globe.

As the student interacts with each family, they learn about the roles and practices of key management practices in feeding the world, reducing environmental impacts and in improving social performance through greater access to education, medical care and community infrastructure.

The journey to feeding the world has started. Journey 2050 can be completed in 6 hours, though you can selectively pick and choose the topics you want to learn about! Real-farm families will guide you through your journey. Remember, every decision you make impacts our world's sustainability – learn to balance social, economic and environmental factors at a local and global scale.

3.3.2 TOP CROP – FARMING FOR THE FUTURE

The goal of *Top Crop* is to introduce students to the complex problems surrounding the growing of food for an increasing population, while ensuring that sustainable practices are used to protect the environment.

During this ten-round experience, students can make choices that impact on how successful their farm will be.

Players need to strike a balance between deploying new technologies to maximize their crop yields, while keeping long-term sustainability goals in mind. When purchasing the technologies to use on the farm, students must be sure to read the descriptions of the technologies. Some technologies are automatically applied to the field, while some require students to take particular actions to receive the benefit from the technology.



3.4 ONLINE TOOLS FOR LEARNING ENGLISH

There is a huge amount of information and professional materials available on the Internet for the study of English.

There are now many dictionaries and translation tools available - for example Google Translate, or the Google Translate plug-in for Google Chrome which can be used to translate [web](#) site in situ. These tools may not provide a perfect translation, but they make it easier for those who do not have enough language skills to understand the content. Youtube and TED videos can also display English subtitles, along many other language subtitles options. They may not be perfect, but they are generally quite usable.

If you want to improve your language skills, there are also many [online](#) options of comprehensive language courses which you can study to develop your writing, grammar and communication skills.

Here are some representative examples.

3.4.1 FREE ONLINE LANGUAGES COURSES.

PERFECTLY SPOKEN

[Perfectly Spoken](#) is a free [online](#) English course. A 10-minute test can be taken to establish your language proficiency. Afterwards you can select a course appropriate to the results achieved - from A1 (a starting level) to C1 (advanced level). There are 5 levels in total.

The course is led by teachers who deliver the course via video. They read the words, explain the tasks and support practice of them with the students.

Each lesson ends with a short self-assessment.

An interesting feature of the course is that you can take part in live practice lessons on the Facebook page of Perfectly Spoken.



<https://perfectlyspoken.com/>

BRITISH COUNCIL

The British Council offers many free [online](#) learning opportunities for adults, teenagers and children. It is possible to study [online](#) or on mobile, learning through tasks, games, video and audio.

The first step is to complete a level test consisting of 25 questions. Following this you undertake the tasks appropriate to the level achieved.

HU: <https://www.britishcouncil.hu/angoltanfolyam/online>

MK: <https://www.britishcouncil.mk/english/mooc>

3.4.2 PRACTISING GRAMMAR

ENGLISH GRAMMAR

Here you can find many and varied tasks to develop your writing and communication skills. The English Grammar pages include:

- downloadable exercises
- downloadable guides
- online exercises
- videos

<https://www.englishgrammar.org/>

LISTENING

[Oxford Online English](#) has a number of Listening Lessons, which can be used to practice listening comprehension. In addition, other types of free tasks are available under [Free lessons](#), for example:

- grammar
- developing vocabulary
- Business English pronunciation
- speaking



PRACTICING SPEAKING IN ENGLISH

Live communication (speech) is one of the most important elements of language learning. The best way to learn is to take lessons from a language teacher whose mother tongue is that which you are trying to learn, though this is not always possible. Nowadays it is common practice to use, as a substitute, some kind of chat software to learn the language along with a teacher supporting online study. It is also possible, and generally free, to look for a conversation partner with whom we can practice that language. There are also many search pages that support this. Here are some examples:

[CONVERSATION EXCHANGE](#)

On this [search page](#) you can specify what kind of native conversation partner you are looking for and what language your partner wants to learn.

In the case below, the partner speaks English and wants to practice Hungarian. Through these options, the site offers a list of potential partners who can speak English and want to learn Hungarian, so they can help each other.



Practice your second language with native speakers

You just need to have the necessary courage to get in touch and to start communicating.

The screenshot shows the website's search interface. At the top, there is a navigation bar with the site logo, a home icon, and menu items for SEARCH, RESOURCES, and ABOUT. On the right side of the navigation bar, there are links for LOG IN, REGISTER, NEWS, and HELP. Below the navigation bar, there are two tabs: 'Search' and 'Results'. The main content area is titled 'Describe your language partner' and contains a form with the following fields:

- Speaks:** A dropdown menu with 'English' selected.
- Learning:** A dropdown menu with 'Hungarian' selected.
- Country:** A dropdown menu with '- All -' selected.
- Town:** An empty text input field.
- Type of Exchange:** Three checkboxes:
 - Face to face conversation
 - Correspondence (Pen-Pal)
 - Using a chat software ?

At the bottom of the form, there are two buttons: 'Search' and 'Reset Form'.

BUSSU

On this site you have to register, select the target language and choose from among the speech partners. This site has 80 million users, so there is every likelihood that you will find the right partner for your needs.



3.4.3 SUMMARY

Nowadays there is every opportunity to be able to learn a language from the comfort of our own home as there is a significant body of teaching materials and tools to support this.

However, it is important that you are able to choose the material that suits you best and allows you to plan your learning. The sites and content must fit with your available time, with what you want to achieve and, of course, fully and comprehensively support you in achieving your goal.

MODULE 1 GLOSSARY

A

ANDRAGOGY - Learning strategies, speciality and the training legality focused on adults.

ASYNCHRONOUS LEARNING - Learning facilitated by media -- such as e-mail and discussion forums -- to support working relationships among learners and teachers, when participants cannot be on-line at the same time.

B

BLENDED LEARNING - a mixture of various learning strategies and delivery methods that can optimize the learning experience of the user. Classroom training sessions, Computer-Based Training (CBT) via a CD-ROM, Web-Based Training (WBT) can be combined to train learners. WBT may be delivered on demand, or at a specific time to involve an instructor and other students.

BLOG - originally called "Web Log" or binary-log, this is means of knowledge sharing on the web. It is a website where the owner (author) publishes personal messages, similar to a daily diary, and other people may reflect upon the entries, or make comments on the messages. Users can post a chronological, up-to-date e-journal entry of their thoughts. This is generally an open forum communication tool but it can perform a crucial function for an organization or company. There are three basic varieties: those that post links to other sources, those that compile news and articles, and those that provide a forum for opinions and commentary.

C

CBT - an abbreviation for Computer Based Training, where the student uses special computer programs to make the learning process more effective and/or efficient.

CDS - an acronym for Content Delivery System. Content types handled include web objects, downloadable objects (media files, software, documents), applications, real time media streams, and other components from the Internet.

CLIENT - an application, or system, that accesses another computer system through a network to use its services.

COMPATIBILITY - The ability of hardware and software systems to work together effectively.

COMPETENCE - a combination of knowledge, skills and behavior utilized to improve performance. It is the state or quality of being adequately or well qualified, having the ability to perform a specific role or a specific job.

COMPUTER SCIENCE - the study of the theoretical foundations of information and computation, and of practical techniques for their implementation and application in computer systems.

CONSTRUCTIVISM - a theory of knowledge which argues that humans generate knowledge and meaning from their experiences. For example, Piaget's theory of learning has had wide ranging impact on learning theories and teaching methods in education and is an underlying theme of many education reform movements.

CURSOR - a small icon on the screen showing the actual position of mouse, or pointing device, or the actual place inside the text where the next letter will be displayed. Its shape will vary when using the mouse to show the nature of the action being carried out.

E

E-LEARNING - Learning/teaching methods which use computer based technologies and the Internet to improve the quality of the education.

E-PORTFOLIO - also known as digital portfolio, this is a collection of electronic evidence assembled and managed by a user, usually on the Web. Such electronic evidence may include inputted text, electronic files, images, multimedia, blog entries, and hyperlinks. These are demonstrations of the user's abilities and platforms for self-expression. If online, they can be maintained dynamically over time.

F

FORMAL LEARNING - learning in traditional schools. Learning progress based on a predetermine curricula, admission, leaving and proceed conditions. State certificates confirm participation and the fulfillment of requirements.

H

HYPERLINK - an active link in a text (source), and a reference to another document (target). It is usually marked with a different color, or an underline, and may point to a whole document or to a specific element within a document.

HYPERMEDIA - a logical extension of the term Hypertext in which graphics, audio, video, plain text and Hyperlinks intertwine to create a generally non-linear medium of information.

HYPertext - a text displayed on a computer or other electronic device with references (Hyperlinks) to other text that the reader can immediately access, usually by a mouse click or key press sequence.

I

ICON - a graphic symbol (usually a simple picture) that denotes a program, or a command, in order to access a specific service quickly in a graphical user interface.

ICT - acronym for Information and Communication Technologies.

INSTRUCTOR - an e-learning developer, who creates learning objects and tasks, plans the training, and is responsible for the e-learning curriculum content and quality. Usually takes part in the training, and helps the tutors' with their work.

INTERACTIVE BOARD - electronic version of a traditional classroom board. With its built-in software, teachers and lecturers can develop sightful, interactive and illustrative curriculums. Can provide Internet connection and a projector.

IPOD - a portable media player marketed by Apple Inc.

K

KNOWLEDGE MANAGEMENT - the process of capturing, organizing, and storing digital information used by individuals and groups within an organization and making it available to others. The information is collected in a central or distributed electronic environment to help the members of the group to share their knowledge with each other.

L

LCMS - an acronym for Learning Content Management System -- a software application (or set of applications) that manages the creation, storage, use, and reuse of learning content. It often stores content in granular forms such as learning objects.

LEARNING OBJECT - a reusable, media-independent collection of information used as a modular building block for e-learning content. It is described with metadata and stored in a data repository, such as an LCMS.

LEARNING OBJECTIVES - synonyms: aims, purposes, goals. The LOs express the intentions of the instructor, describe what he/she want to achieve within the module. They are clear concepts to express the direction of the module, they are descriptions of the most important competences the module will develop. Broad statements that will include many subordinate competences.

All the applied tools (learning elements, course components, methods, coaching) to deliver the module, should promote the participants to achieve the LOs. The teaching effectiveness of the instructors' will be evaluated against the objectives.

LINK - an element of an electronic source of information - signed by a special color or underlined text - that branches from one site page to an other after clicking on it.

LLL - Lifelong learning. An idea that learning can, and does, occur beyond the formal structure of an educational institution and occurs throughout one's lifetime.

LMS - learning management system. Software that automates the administration of training. It registers users, tracks courses in a catalog, records data from learners; and provides reports to management. It is typically designed to handle courses by multiple publishers and providers. It usually doesn't include its

own authoring capabilities; instead, it focuses on managing courses created by a variety of other sources.

M

MOODLE - an open source Course Management System (Modular Object-Oriented Dynamic Learning Environment) originally developed by Martin Dougiamas. It is used by thousands of educational institutions around the world to provide an organized interface for e-learning, or learning over the Internet.

It allows educators to create online courses, which students can access as a virtual classroom. Typically its home page will include a list of participants (including the teacher and students), a calendar with a course schedule and list of assignments. Other features may include online quizzes, forums - where students can post comments and ask questions - glossaries of terms, and links to other Web resources.

Official website: <http://www.moodle.org>.

MOUSE - in computing this is a pointing (input) device that functions by detecting two-dimensional motion relative to its supporting surface. Physically, it consists of an object held under one of the user's hands, with one or more buttons.

MULTIMEDIA - several media in one system. It conveys message through several channels at the same time and it is able to integrate several media (texts, audio elements, pictures, videos, animations) into a communication system.

O

OFFLINE - describes a system which is, at the moment, not connected (generally electrically) to a network.

ONLINE - the state in which a computer is connected to another computer or server via a network. A computer communicating with another computer.

P

PODCAST - a digital recording of a radio broadcast or similar program, made available on the Internet for downloading to a personal audio player. Originally derived from a combination of "broadcasting" and "iPod™," the word was declared "word of the year" when it was added to the dictionary at the end of 2005.

PORTAL - a dynamic website that acts as a doorway to the Internet or a portion of the Internet, targeted towards one particular subject, and related to the subject, it provides several functions for the visitor.

S

SCORM - an acronym for Sharable Content Object Reference Model: a set of specifications that, when applied to course content, produces small, reusable learning objects. Courseware elements following

this standard can be easily merged with other compliant elements to produce a highly modular repository of training materials.

SERVER - a computer with a special service function on a network, generally to receive and connect incoming information traffic.

SOCIAL CONSTRUCTIVISM - a sociological theory of knowledge that applies the general philosophical constructionism into social settings, wherein groups construct knowledge for one another, collaboratively creating a small culture of shared artifacts with shared meanings. (Source: wikipedia)

SYNCHRONOUS LEARNING - a real time learning event in which all of the participants are logged on at the same time and have the ability to communicate with each other.

T

TACIT KNOWLEDGE - knowledge that people carry in their minds and, therefore, difficult to identify. Often, people are not aware of the knowledge they possess or how it can be valuable to others.

TUTOR - he or she helps the student to navigate, to fulfill the assignments in an online learning environment by using online communication and collaboration tools like e-mail, forum, chat, webinar. He/she follows the learning progress of the students and evaluate their performance.

V

VLE - acronym for the digital version of the traditional classroom (Virtual Learning Environment), with electronic curricula, digital learning materials, communication facilities and interactive elements. It supports the learning process and the teachers' work (curriculum writing, storing, follow up students' development, controlling and evaluation).

W

WBT - acronym for Web-Based Training. Delivery of educational content via a Web browser over the public Internet, a private intranet, or an extranet. Web-based training often provides links to other learning resources such as references, email, bulletin boards, and discussion groups. It also may include a facilitator who can provide course guidelines, manage discussion boards, deliver lectures, and so forth. When used with a facilitator, it offers some advantages of instructor-led training while also retaining the advantages of computer-based training.

WEB 2.0 - the term is commonly associated with Internet applications that facilitate interactive information sharing, interoperability, user-centered design, and collaboration on the World Wide Web. Such applications serve functionalities for web-based communities, hosted services, social-networking, video-sharing, include wikis, blogs, mashups, and folksonomies. They enables the users to interact with other users or to change website content, in contrast to non-interactive websites where users are limited to the passive viewing of information that is provided to them.

WEB CONFERENCE - a meeting of participants from disparate geographic locations that's held in a virtual environment on the World Wide Web, with communication taking place via text, audio, video, or a combination of those methods.

WEBCAST (Web + broadcast) - a broadcast of video signals that's digitized and streamed on the World Wide Web, and which may also be made available for download. (verb) To digitize and stream a broadcast on the World Wide Web.

WEBINAR (Web + seminar) - a synchronous online learning event in which a presenter and audience members communicate via text chat or audio about concepts often illustrated via online slides and/or an electronic whiteboard. These events are often archived as well for asynchronous, on-demand access.

EUROPEAN STRATEGIES AND INITIATIVES IN E-AGRICULTURE

Module 2

4 WHAT IS E-AGRICULTURE?

E-agriculture is an emerging field focusing on improving agricultural and rural development through information and communication processes. It covers the design, development, evaluation and application of innovative ways of using information and communication technologies (ICT) in rural areas with a focus on agriculture.



Figure 11: Source: FAO e-Agriculture Strategy Guide

Agriculture of the future will be digitally integrated at all stages of production and distribution. The main objective of implementing digital agriculture is to improve decision making for farmers, agribusiness, policy-makers and researchers. In order to achieve the basis of a digital agriculture system, accurate and reliable agriculture information is needed (Xu, 2012, P.1, E. Toppuli 2017).

4.1 WHY E-AGRICULTURE IS IMPORTANT?

The UN's Food and Agriculture Organisation (FAO) forecasts show that the world's population could grow by 2.3 billion by 2050 and reach 9.1 billion by 2050. At the global level, agricultural production and consumption will be 60% higher by 2050 than they are today. This must be achieved despite the limited availability of arable land, the growing need for fresh water and the effects of climate change.

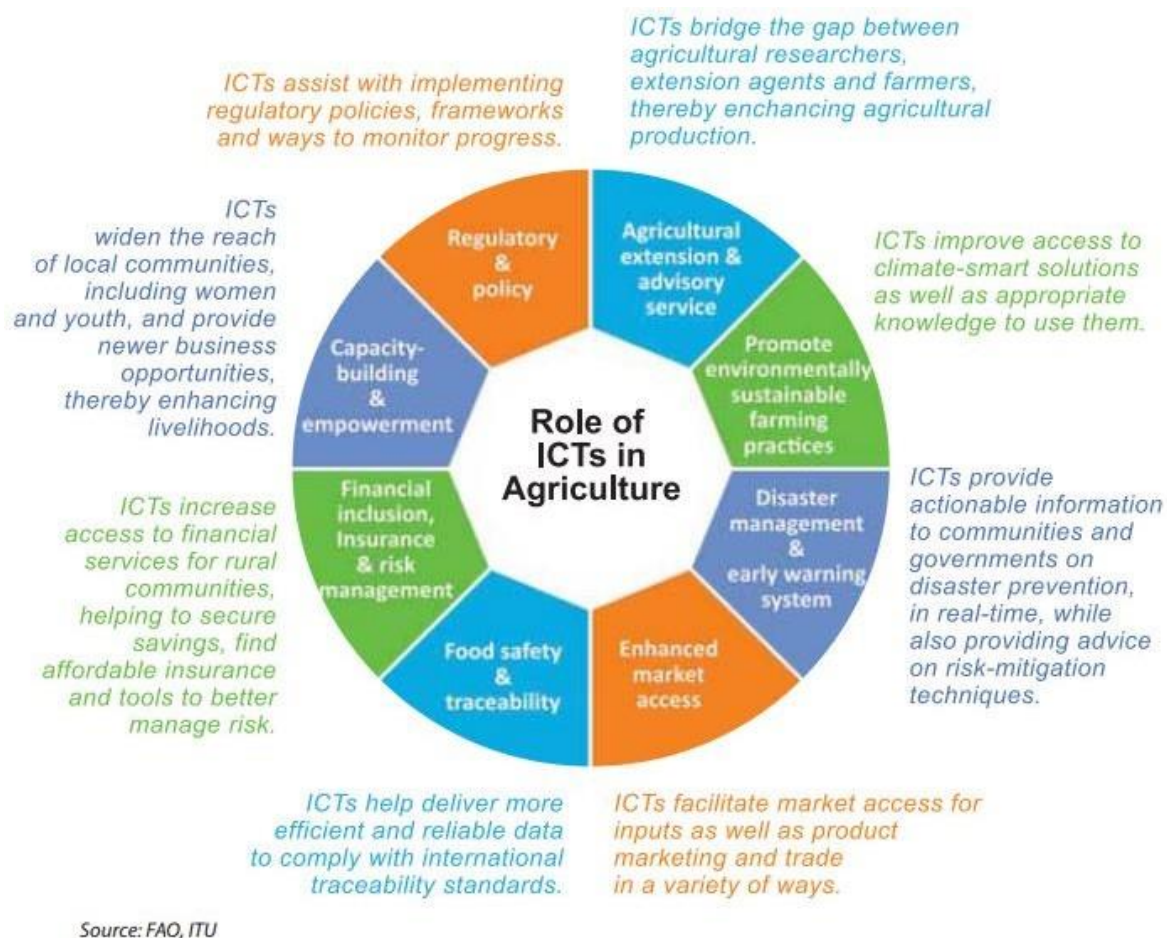

Figure 12: Source: FAO e-Agriculture Strategy Guide

Innovative approaches - including information and communication technologies (ICTs) - are needed throughout the agricultural sector to increase productivity, conserve natural resources and make sustainable and efficient use of inputs. [E-agriculture](#) is one of the lines of action set out in the Declaration and Action Plan of the World Summit on the Information Society (WSIS).

4.1.1 STATUS OF E-AGRICULTURE IN THE REGION

How e-agriculture is developed and managed can vary by the different continents and regions of the globe, even countries within a region can have their specifics in the use of ICTs in agriculture.

The [FAO](#) Regional Office for Europe and Central Asia has published a status report on the E- Agriculture implementation within selected [FAO](#) member countries in the region.

The publication is a follow-up to the Regional Workshop on National e-Agriculture Strategies in Europe and Central Asia, organized by [FAO](#) and GAK - a non-profit organization of St Istvan University in Gödöllő, Hungary.

The publication contains country profiles, regional summaries and a collection of good practices and lessons learnt in the use of ICTs.

As a continuation to the regional effort, there is work in the pipeline to develop an [online](#) platform called the 'Regional [E-agriculture](#) Observatory', which - among other functions - enables queries to be run against an aggregated database of regional e-agriculture indicators, to provide a unified e-ARI (e-agriculture readiness) index: <http://www.agrowebcee.net/awhu/e-agriculture-strategy/ecaobserver/>

4.1.2 PLETHORA OF DEFINITIONS AND SIMILAR CONCEPTS

One frequently encounters terms such as [E-agriculture](#), [Digital Agriculture](#) or Digital Farming, [ICT4AG](#) (or ICTs for Agri), [Precision Agriculture](#), [Agriculture 4.0](#), [Smart Farming](#) etc in the professional domain of AgriTeach 4.0, that often refer to similar, or even the same, topics. We attempt to provide simple definitions in the module [glossary](#) for each of the terms, though we do not rank their importance or attempt to depict them in some overall framework.

The AgriTeach 4.0 project does attempt to deal with all essential topics and subjects in '[Smart Farming](#)' that are relevant for students and teachers in the vocational agricultural education .

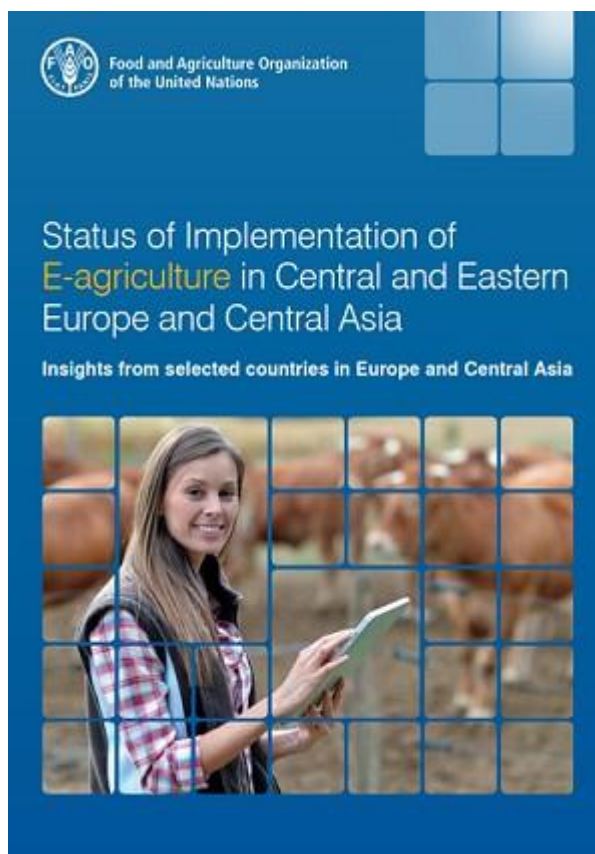

5 EU POLICY FOR DEVELOPMENT OF INNOVATION AND ICT

The Digital Agenda presented by the European Commission ([EC](#)) is one of the seven pillars of the Europe 2020 strategy, which sets goals for [EU](#) growth by 2020.

The Digital Agenda proposes to make better use of the potential of [ICT](#) to foster innovation, economic growth and progress. As a part of the Digital Agenda, the Digital Single Market of the [EU](#) ([DSM](#)) is one of the key priorities of the [EC](#).

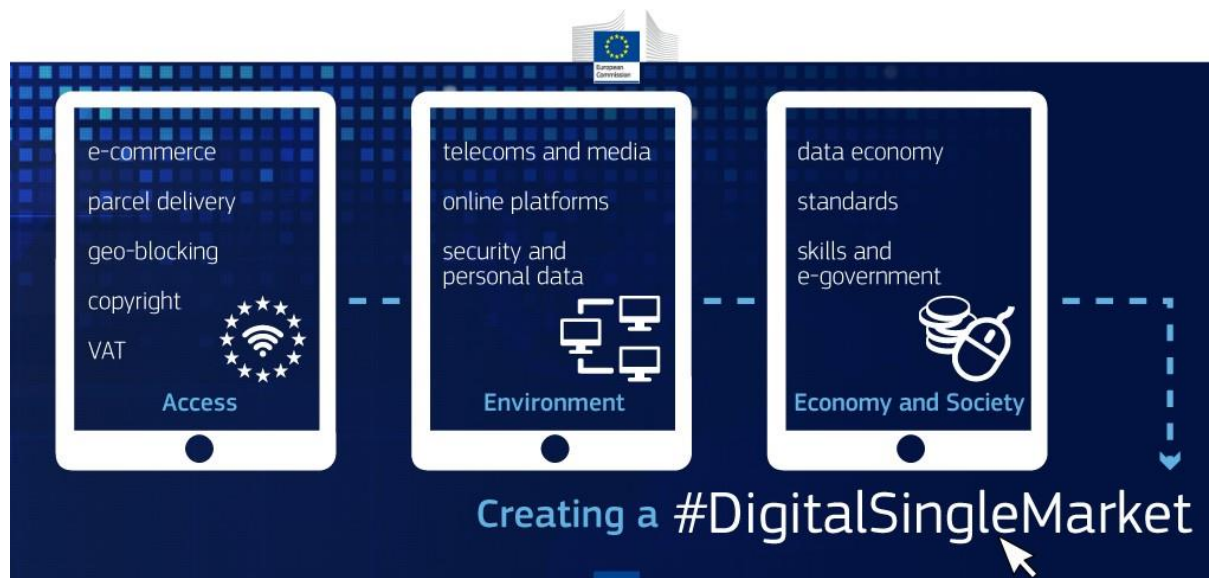

The main policy context of e-agriculture in the [EU](#) is also determined at the top level by the [DSM](#) Strategy.

One of the objectives of the [DSM](#) package is to bridge the digital divide between urban and rural areas and to provide high-speed / ultra-fast broadband across the [EU](#) by 2020.

The Digital Single Market also offers many other opportunities for agriculture and the food value chain - all the way to the consumer - to become smarter, more efficient, more circular and more connected.

Source: <http://ec.europa.eu/programmes/horizon2020/en/news/digitising-agriculture-and-food-value-chains>

Digitising European Industry [COM(2016)180] "...any industry in Europe, big or small, wherever situated and in any sector can fully benefit from digital innovations to upgrade its products, improve its processes and adapt its business models to the digital change."

The [Cork 2.0](#) declaration (point 7) states: " Rural businesses, including farmers and foresters, of all type and sizes must have access to appropriate technology, state-of-the-art connectivity, as well as new management tools to deliver economic, social and environmental benefits"

https://ec.europa.eu/agriculture/events/rural-development-2016_en



Various forms of available sources of funding can help launch an agricultural innovation project, e.g. the European rural development policy under the [CAP](#), the [EU's](#) Horizon 2020 research and innovation program ([H2020](#)), or the European Innovation Partnership program ([EIP](#)).

5.1 EIP-AGRI

[EIP-AGRI](#) is the abbreviation for the 'European Innovation Partnership for Agricultural productivity and Sustainability', launched in 2012 to contribute to the European Union's strategy 'Europe 2020' for smart, sustainable and inclusive growth. An interactive approach, it is one of the five main objectives of the strategy.

The [EIP-AGRI](#) plays a role in integrating different funding streams so that they can synergistically contribute towards a common goal and result. Rural Development programmes in particular support common Operational Groups ([OGs](#)) and Innovation Support Services within a country or region.

The main steps of implementing a successful [EIP-Agri](#) project will include:

1. Elaborate the Idea

In EIP-AGRI projects the problem being addressed, and the need for some innovation solution, must come directly from the farm and farmer. It should be practical, reasonable and the hoped-for solution also applicable to similar use cases of other farmers. In other words, the idea always needs to tackle a concrete issue that farmers currently face - a realn (practical) problem or opportunity which may lead to an innovation.

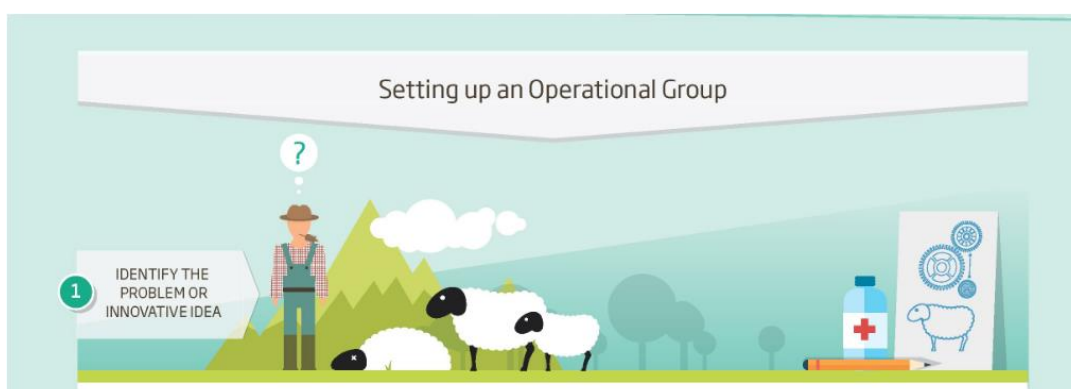

2. Setting up a team.

OGs (operational groups) are composed of individuals who work together in a project to turn innovative ideas into real solutions for the field. OGs bring together partners with complementary knowledge and skills. The composition of the group can vary according to the theme and specific objectives of each project. The innovation actors may be farmers, advisers, researchers, businesses, NGOs and others at EU level and within the RDPs. An OG is composed of those key actors who are in the best position to realise the project's goals, and who will share the implementation experiences and disseminate the outcomes to a wider audience. Thus the OG approach makes the best use of different types of knowledge (practical, scientific, technical, organisational, etc.) in an interactive way.

3. Plan and implement.



Once the idea and the team are in place, it is time to design the project activities, with a focus on the field, farm tests and experiments. To make sure that all partners understand the project that they are working on together, and how to turn the idea into an innovation, the application needs to contain a clear outline of the different stages of the project.

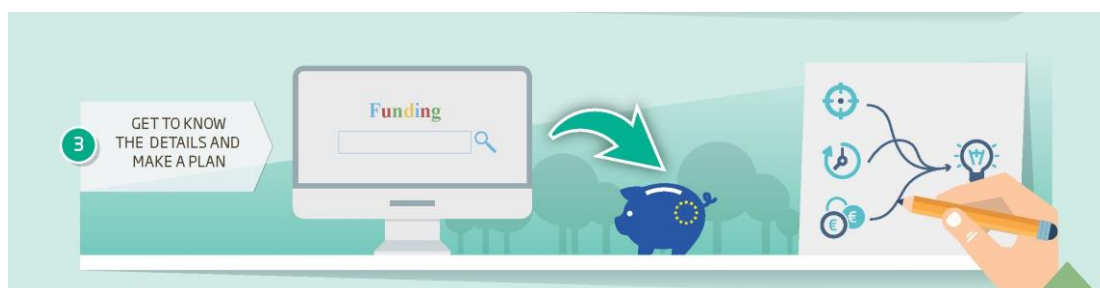

4. Disseminate. Sharing and disseminating project results is a key element of [EIP-AGRI](#) projects. The project should ensure that it puts in place some dissemination mechanism that enables other farmers in Europe with a similar problem find, understand and adopt any results. Every [OG](#) must implement this final step, to spread the knowledge that the group has collected, and to make sure that the results can be used by farmers and foresters across Europe.



More resources: <https://ec.europa.eu/eip/agriculture/>

5.2 H2020

Horizon 2020 is the EU's largest research and innovation program, providing funding of nearly € 80 billion between 2014 and 2020. It finances multi-stakeholder projects and thematic networks with partners from at least three EU countries. These are usually large innovation projects developed by major European consortia.

Its work program 2018-2020, particularly Chapter 9 (Food security, sustainable agriculture and forestry, marine, marine and inland water and bioeconomy) provides details of the actual calls.

http://ec.europa.eu/research/participants/data/ref/h2020/wp/2018-2020/main/h2020-wp1820-food_en.pdf

5.2.1 H2020 PROJECTS RELATED TO DIGITAL AGRICULTURE

Title	Topic	URLs
4D4F	Data Driven Dairy Decision For Farmers (4D4F) aims at developing a network for dairy farmers, dairy technology suppliers, data companies, dairy advisors, veterinarians and researchers to improve the decision making on dairy farms based on data generated by sensors.	https://4d4f.eu/
AGROIT	The project aims to implement an open platform based on open standards to increase efficiency of farming. It will deliver applications and services to various stakeholders: farmers, local communities, state institutions, consulting institutions in farming (government founded and private) and EU institutions.	https://www.agroit.eu
APOLLO	The project aims to develop a market-ready platform of agricultural advisory services focused primarily, but not exclusively, at smallholder farmers in Europe, especially bringing benefits of precision agriculture to farmers through affordable information services, making extensive use of free and open EO data, such as those provided by the EU's Copernicus programme. These services will help farmers to make better decisions by monitoring the growth and health of crops, providing advice on when to irrigate and till their fields and estimating the size of their harvest.	http://apollo-h2020.eu/
BIGDATAEUROPE	The project's main objective is to implement Big Data solutions based on the usage of large volumes and heterogeneous Earth Observation datasets. This should help addressing key Societal Challenges, so the users can focus on the analysis of the extraction of the potential knowledge within the data and not on the processing of the data itself.	https://www.big-data-europe.eu/food/

CAPSELLA	It develops innovative ICT solutions tailored to the needs of all food, field and seed related actors engaging in agrobiodiversity. CAPSELLA has prototyped new open data based products which enhance the processes and viability of agrobiodiversity.	http://www.capsella.eu/
DataBio	The Data-Driven Bioeconomy project focuses on the production of best possible raw materials from agriculture for the bioeconomy industry to produce food, energy and biomaterials taking into account responsibility and sustainability DataBio is controlling and putting to use the innovative ICTs and information flows centered mostly around the use of proximal and remote sensors, in order to provide a streamlined Big Data Infrastructure for data discovery, retrieval, processing and visualizing, in support to decisions in bioeconomy business operations.	https://www.data.bio.eu
FOODIE	The key point of the project is creating a platform hub on the cloud where spatial and non-spatial data related to agricultural sector are available for agri-food stakeholders groups and interoperable. It offers an infrastructure for the building of an interacting and collaborative network; the integration of existing open datasets related to agriculture; data publication and data linking of external agriculture data sources, providing specific and high-value applications and services for the support of planning and decision-making processes.	http://www.foodie-project.eu/
eROSA	The strategic goal of e-ROSA is to provide guidance to EU policies by designing and laying the groundwork for a long-term programme aiming at achieving an e- infrastructure for open science in agriculture that would position Europe as a major global player at the forefront of research and innovation in this area.	http://erosa.aginfra.eu
EU -PLF	Precision Livestock Farming (PLF) offers a range of technologies to continuously monitor farm animals and their immediate environment. The observation data can be translated into key indicators on animal welfare, animal health, productivity and environmental impact. A number of PLF tools have been developed at laboratory levels and as prototypes.	http://www.eu-plf.eu/
ICT -AGRI	Main objective is to strengthen European research within the area of precision farming and to develop a common European research agenda. ICT -AGRI develops international research calls.	http://ict-agri.eu/

IoF2020	The aim is to build a lasting innovation ecosystem that fosters the uptake of IoT technologies. Nineteen use-cases organised around five sectors (arable, dairy, fruits, meat and vegetables) develop, test and demonstrate IoT technologies in an operational farm environment all over Europe.	https://www.iof2020.eu/
ReCAP	It aims to develop an improved remote monitoring of CAP obligations and to supplement the in-field inspections procedures eliminating several burdens. They offer farmers a tool supporting them to comply with regulations imposed by the CAP , providing personalised information for simplifying the interpretation of complex regulations, and early alerts on potential non-conformities.	https://www.recap-h2020.eu/
Smart- AKIS	Smart- AKIS is a European Network mainstreaming Smart Farming Technologies among the European farmer community and bridging the gap between practitioners and research on the identification and delivery of new Smart Farming solutions to fit the farmers' needs.	https://www.smart-akis.com/

More information from key events during 2017 and 2018:

- 2-3 May 2018
<https://ec.europa.eu/programmes/horizon2020/en/news/agriresearch-conference-innovating-future-farming-and-rural-communities>
- 5 February 2018
<http://copernicus.eu/agriworkshop>
- 24 Nov 2017
<http://ict-agri.eu/node/38607>
- 17 Nov 2017
<http://ec.europa.eu/programmes/horizon2020/en/news/digitising-agriculture-and-food-value-chains>
- 29-31 May 2017
<https://ec.europa.eu/jrc/en/event/workshop/iacs-workshop-2017> More resources:
<https://ec.europa.eu/programmes/horizon2020/>

5.3 EARTH OBSERVATION

5.3.1 COPERNICUS PROGRAMME

Copernicus is the Earth observation program of the European Union. It is served by a number of dedicated satellites (the Sentinel family) and various contributing missions (existing commercial and public satellites). The Copernicus services convert this wealth of satellite data into value-added information by processing and analyzing the data.

The information services offered are free and open to all users.

For example, the Copernicus Land Monitoring Service provides geographic information on land cover, land use, land use change over the years, vegetation state or water cycle.

There several different types of Sentinel satellites, typically, each mission consists of two satellites in order to ensure faster data recovery. Every Earth exploration mission must also provide ground operations in addition to the satellites. It is responsible for managing satellites, receiving and processing data, and for making data available.

Copernicus has its ground segment divided into two main parts: The Core Ground Segment and the Collaborative Ground Segment.

The Core Ground Segment enables the systematic retrieval, processing and distribution of all Sentinel satellite data. It includes elements for tracking, managing satellites, and for downloading, processing, and spreading data to users. It also has mechanisms to monitor and control the quality of data products, as well as data

archiving. Infrastructure is "distributed", which means that different centers are in different places but are interconnected and coordinated. Despite the complexity of the system, users are offered a single virtual access point to find and download products.

The main parts of the Core Ground Segment are:

- Flight Operation Segment (FOS) - responsible for all operations of Sentinel satellites, including monitoring and controlling and controlling platform activities,
- ground stations - where data is processed, and outputs are generated almost in real time,
- Processing and Archiving Centers (PAC) - where critical data processing is systematically performed. All data products are archived for online access by users,
- Mission Performance Centers (MPC) - responsible for calibration, validation, quality control and performance evaluation of the entire system, Precise Orbit Determination (POD) - uses GNSS receiver data to provide orbital information needed to generate data products,
- the Copernicus Space Component encryption network (CSC WAN) - allows all products and additional data to be delivered to various ground- based devices and provides end-users with expanded data products.

All acquired program data are systematically processed up to the specified level and according to different time horizons. Outputs are usually available within 3 - 24 hours of satellite data acquisition.

The Collaborative Ground Segment provides additional access to Sentinel data, or to specific data products or distribution channels. It consists of elements funded by third parties (i.e. outside the [ESA](#) / [EU](#) Copernicus program) and provides a framework for international cooperation.

Cooperation elements are expected to deliver specialized solutions that further extend the use of Sentinel missions in different areas:



- data acquisition and quasi-real-time production - this is the situation where local land stations are configured to receive data directly during direct satellite viewing,
- complementary product definition and customization algorithms for regional coverage or specific applications,
- expanding and accessing data supporting the redistribution of major products by creating additional distribution points (e.g. mirror pages), development of innovative tools and applications,
- additional support for calibration / validation activities.

5.3.2 EO DATA SOURCES

SENTINEL-1

Purpose: very precise land and sea monitoring.

Monitoring: sea ice; water and seashores; polar regions; forest stands; agricultural land use (primarily changes), soil deformation, snow cover.

Usage: crisis management; forecasting and monitoring the impact of climate change. Characteristics: work regardless of cloud conditions.

The Sentinel 1 images are supplied by two polar orbiting satellites that operate day and night with synthetic aperture C-band radar to capture images regardless of the weather.



The identical satellites orbit the earth 180 ° and at a height of nearly 700 km and provide a global revision time of six days. The radar of Sentinel-1 can work in four modes.

SENTINEL-2

Purpose: Multispectral high-resolution surface monitoring.

Monitoring: mapping, detection of surface changes, monitoring of geophysical changes.

Usage: monitoring of climate change, surface monitoring, crisis management, security monitoring, spatial planning, agronomic and environmental monitoring, monitoring of water areas, forests and vegetation.



Characteristics: very frequent scanning of the same place, activity is influenced by cloudiness

The satellite carries a multispectral imager with a width of 290 km. The Imager offers a versatile set of 13 spectral ranges, ranging from visible and near-infrared to short-wave infrared, with four spectral bands at 10 meters, six bands at 20 meters, and three bands at 60 meters spatial resolution.

Sentinel 2 image data is hosted by Amazon [Web Services](#) as part of its [Open Data](#) registration. Users can access images from Sentinel-2 on AWS, or alternatively, access Sentinel2Look Viewer, EarthExplorer, or the Copernicus Open Access Hub to download the scenes.

[Space video](#)

http://www.esa.int/Our_Activities/Observing_the_Earth/Copernicus/Sentinels_modernise_Europe_s_agricultural_policy

SENTINEL-3

Purpose: multi-sensor surface monitoring.

Monitoring: topology of water areas, surface sea temperatures, soil colors, watercolors, wind speeds in 10m/s, vegetation state, fires.

Usage: predictions of ocean and seas behavior, weather forecasts, coastal water monitoring, water level monitoring and changes, monitoring of climate change.

Characteristic: partly dependent on the cloud conditions.



LANDSAT

The Landsat program is the longest-running acquisition program for Earth satellite imagery, being active since 1972. The latest Landsat 8 was launched on February 11, 2013.

The images are a unique resource for research and applications in agriculture, cartography, geology, forestry, regional planning, monitoring and education.

Landsat 8 data has eight spectral bands with spatial resolutions of 15 to 60 meters. The temporal resolution is 16 days.



5.3.3 USING COPERNICUS EO SERVICES IN CAP MONITORING

The current legislative framework of the 2013 [CAP](#) will be reformed in 2020 in order to modernize and simplify the [CAP](#). With this upcoming [CAP](#) reform, Earth Observation ([EO](#)) will play an increasingly important role in improving [IACS](#) and its cost-effectiveness.

Based on a proposal by the DG-Agri, a new approach to monitoring the [CAP](#) was introduced in May 2018, where Copernicus Sentinels and other Earth observation missions data now replace the physical need to visit farms for necessary checks for the [EU](#) to issue payments to farmers.



SEN4CAP PROJECT

In conjunction with the national authorities of six selected [EU](#) pilot countries (Czech Republic, Italy, Lithuania, Netherlands, Romania, Spain) the Sen4CAP consortium is currently demonstrating how the Sentinels can be used nationally for the new [CAP](#) monitoring approach. <http://esa-sen4cap.org/>

5.3.3.1 OTHER TOOLS AND TECHNOLOGIES USING [EO](#) DATA

- [IrrisAT](#) - look up [Agritech 4.0. / Technologies](#)



- [Cropsat](#) - look up [Agritech 4.0. / Technologies](#)

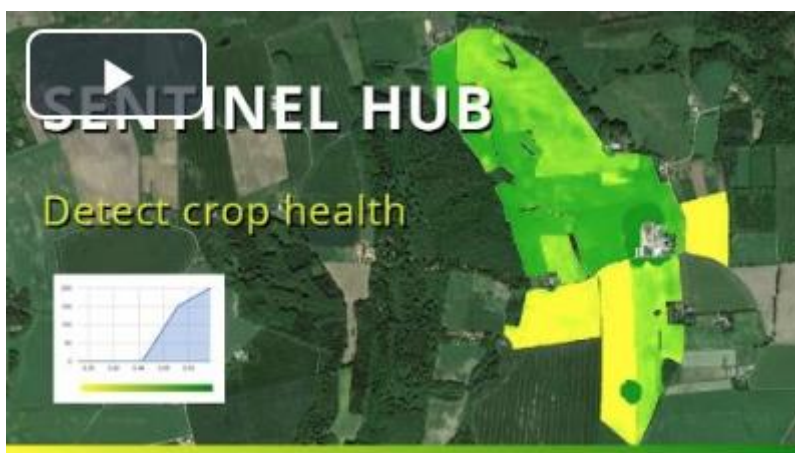

- [KORE](#) - look up [Agritech 4.0. / Technologies](#)
- [Agromonitoring.com](#) - look up [Agritech 4.0. / Technologies](#)
- [Cropio](#)



6 INFORMATION SYSTEMS IN THE COMMON AGRICULTURAL POLICY

The agri-food sector is one of the largest in the [EU](#). Around 44 million jobs in food processing, food retailing and catering depend on agriculture, of which there are currently around 12 million farmers. About half of the [EU](#) territory is farmed. Rural areas make up half of Europe and are inhabited by about 20% of the [EU](#) population.

The Common Agricultural Policy ([CAP](#)) is the agricultural policy of the European Union. It operates a complex system of agricultural subsidies and other support programs. [CAP](#) was introduced in 1962 and has undergone several changes. The [CAP](#) has a budget of over € 50 billion a year, making it the most expensive program in the European Union. The [CAP](#) accounted for 37.8 percent of the [EU](#) budget from 2014 to 2020, compared with almost 71 percent in 1984.

The [CAP](#) aims to sustainably improve the productivity of European agriculture while ensuring a fair standard of living for farmers in the [EU](#). It strengthens the competitiveness and sustainability of agriculture in Europe through a range of measures such as direct payments, market measures and rural development.

Most of the [CAP](#) budget is managed and controlled through its Integrated Administration and Control System ([IACS](#)) to protect the [CAP](#)'s financial resources and assist farmers in making their declarations.

The [CAP](#) budget is used in three different, but interrelated, areas therefore funds need to be allocated in a coherent way:

- **Income support** for farmers and support for sustainable agricultural practices: Farmers receive direct payments provided they comply with food safety, environmental protection, animal health and animal welfare standards. Direct payments are fully funded by the [EU](#) and account for 70% of the total [CAP](#) budget. Thirty per cent of direct payments depend on adhering to sustainable agricultural practices that improve soil quality, biodiversity and the environment, e.g. diversification of crops, maintenance of permanent grassland or conservation of organic land on farms.
- **Rural development** measures: to help farmers modernize their farms and become more competitive while protecting the environment, diversifying agricultural and non-agricultural activities, and contributing to the vitality of rural communities. These payments are co-financed by the Member States, and amounting to around 20% of the total [CAP](#) contribution. Projects typically last more than a year.
- **Market support** measures: These payments finance, for example, market support measures such as export subsidies to food companies, and help when unfavorable weather conditions destabilize the markets. These account for less than 10% of the overall [CAP](#) budget.

Agricultural Information Systems (AIS) - according to [EU](#) standards - fall in the following two general categories:

1. Primary Information Systems,
 - a. Agricultural Statistics
 - b. Farm Accountancy Data Network ([FADN](#)) for the monitoring of financial processes and income position of farms
 - c. Market Information System for providing market trend data for producers and government
 - d. Bulk of systems used in the allocation of support, including, in particular, the essentially 'technical' Integrated Administration and Control System ([IACS](#)) used for in the administration of [EU](#) for the posting and monitoring of payments.
2. Secondary information systems that typically use the databases of primary systems. They are designed to meet the specific information needs of certain 'narrower' areas, including ICTs for [AKIS](#) and farm advisory services.

6.1 THE INTEGRATED ADMINISTRATION AND CONTROL SYSTEM

Member States must take the necessary measures to ensure that transactions financed under the European Agricultural Guarantee Fund of the [CAP](#) are actually carried out and executed correctly, and to prevent and manage irregularities. To this end, Member States should operate an integrated administration and control system ([IACS](#)) for all direct payments.

The [IACS](#) consists of interconnected digital databases and subsystems that receive and process claims and application and related data.

1. A unique identification system for farmers.
Registration is a precondition of granting support from the funds administered by the Paying Agency. The central registration system shall manage the registration process, data updates (change management), legal succession, authorizations and delegation of authority. One central farmer registry interfaces with other connected services.



Figure 13: Source: mepar.hu

2. An identification system covering all agricultural areas called "Land Parcel Identification System" ([LPIS](#)).
A Land Parcel Identification System ([LPIS](#)) is an IT system based on aerial or satellite photographs recording all agricultural parcels in the Member States. It is a key control mechanism under the Common Agricultural Policy ([CAP](#)) designed to verify eligibility for area-based subsidies. Close to half of the payment errors were area-related. The system also increasingly plays a role in checking compliance with various environmental obligations. Example screenshot of Hungarian [LPIS](#) browser, displaying [GIS](#) layers and metadata of the so called physical blocks:
3. An identification system for payment entitlements.
In order to receive direct payments, each year farmers have to submit a unified claim (aid application) listing all the agricultural parcels on their holding. Farmers can have their payments reduced if they do not comply with the rules of the specific schemes they applied for, and generally with cross compliance issues, keeping the land under good agricultural condition, food safety, animal health and welfare and environmental protection and other rules.

4. A system for identification and registration of animals.
For individual bovine animals the system includes the following elements:
 - a. double eartags for each animal with an individual number
 - b. maintaining a register on each holding (farm, market, etc.)
 - c. bovine-passports
 - d. a computerised database at national level with a future voluntary [interoperability](#) of bovine databases.

To enhance food safety and better safeguard animal health in the [EU from 18 July 2019](#), bovine animals will be allowed to be identified using two means of the identifications: conventional ear tag and **an electronic identifier**.

The fulfilment of the criteria for receiving aid is assessed through administrative controls and through checks carried out on-the-spot.

Several countries in the process of [EU](#) accession are already at advanced stages of information systems development, which are typically considered as modules of the national [IACS](#), while some other countries in the region have started e-agriculture projects with functionalities similar to [IACS](#).

More resources:

- [IACS: https://ec.europa.eu/agriculture/direct-support/iacs_en](https://ec.europa.eu/agriculture/direct-support/iacs_en)
- [LPIS: https://publications.europa.eu/en/publication-detail/-/publication/11049e0e-9a82-11e6-9bca-01aa75ed71a1/language-en](https://publications.europa.eu/en/publication-detail/-/publication/11049e0e-9a82-11e6-9bca-01aa75ed71a1/language-en) Direct payments: https://ec.europa.eu/agriculture/direct-support/direct-payments_en
- Bovine register. https://ec.europa.eu/food/animals/identification/bovine_en

6.2 OTHER CAP RELATED INFORMATION SYSTEMS

6.2.1 FARM ACCOUNTANCY DATA NETWORK ([FADN](#))

The [FADN](#) is a system for conducting surveys that are carried out each year to collect accounting data from sample farms with the aim of monitoring the income and operations of agricultural holdings in the [EU](#). The [FADN](#) is an important source of information for understanding the impact of [CAP](#) measures on different types of farms.

Main features of [FADN](#):

- It informs on the economic situation of farmers; Most data is based on accountancy records; Data is confidential;
- Participation is voluntary;
- It samples 80 000 farms annually from a total of 5 million observed farms in the EU.

[FADN](#) data is used in: agricultural policy ([EU](#) and national) development; economic research; extension services and as input for other statistics. Observations are requested according to three criteria:

1. region
2. economic size
3. type of farming

therefore farms are selected in the sample to guarantee its representativeness.

Based on the economic size of farm, the type of farming activity and geographical location (region) of the farm, the [FADN](#) typology can determine and generate results that place each individual farm into its respective group. Such farm classification can be important in e- agriculture solutions which have services tailored to the special needs of the users. For example the farm advisory system / one stop shop

solution demonstrated in chapter 5.2. uses such farm typology mechanism to create a profile of the farmer user.

Activity groups: http://ec.europa.eu/agriculture/rica/detailtf_en.cfm?TF=TF14&Version=11990

The results of [FADN](#) data is not only usable for policy makers, but their publication - in addition to the aforementioned opportunities of farm typology for [ICT](#) services and developers - can bring benefit for farmers by, for example, bench-marking data lines, comparing their own performance with the average of the sample, positioning within the upper and lower segment etc. [FADN](#) data results can also be a basis for evaluation of business plans, often requested to be attached to rural development project proposals. These are a very useful tool in assisting the preparation of aid applications.

6.2.2 MARKET PRICE INFORMATION SYSTEM

The European Commission closely follows pricing situations and market trends for agricultural commodities and food, and publishes various reports during the year. The information is published on their website: https://ec.europa.eu/agriculture/markets-and-prices_en

The Price Dashboard provides a monthly summary of commodity price data for the most representative food products and consumer prices at [EU](#) level and worldwide.

https://ec.europa.eu/agriculture/sites/agriculture/files/markets-and-prices/price-monitoring/dashboard/food04-2018_en.pdf

6.2.3 EUROSTAT

Agricultural statistics cover topics such as:

- information on the structure of farms, orchards and vineyards; agricultural production;
- economic accounts for agriculture; agriculture and the environment.

More resources: <http://ec.europa.eu/eurostat/web/agriculture/overview>

<http://ec.europa.eu/eurostat/web/agri-environmental-indicators/indicators>

7 STRATEGIC MANAGEMENT OF E-AGRICULTURE

The establishment of a national e-agricultural strategy is an important step for any country that wants to use [ICT](#) for agriculture.

An e-agricultural strategy can provide crucial support for rationalizing resources (financially and humanely), making better use of [ICT](#) opportunities and tackling challenges in the agricultural sector. The strategic approach can help prevent e-agriculture projects from being isolated and generate efficiency gains through synergies inside and outside the sector.

This chapter introduces the key elements of information management for a successful national e-agriculture and then presents briefly a focused handbook that outlines in more detail how strategy can be developed to achieve this goal.

More resource: <http://www.fao.org/e-agriculture/e-agriculture-strategies>



7.1 STANDARDS

[E-agriculture](#) standards and [interoperability](#) components are needed to enable consistent and accurate collection and exchange of agricultural information across geographic and agricultural sector boundaries. Without these components, agricultural information would be susceptible to misinterpretation and difficult to share, due to incompatibilities in data structures and terminologies.

Components	Description	Examples
Data structure standards	These standards govern the way agricultural data sets are stored, using consistent data structures. Data can then be presented with consistency in software applications, to ensure information is neither misinterpreted nor overlooked.	FAO's Agricultural Information Management Standards (AIMS) supports standards, technology and good practices for open access and open data in the agricultural domain; Geospatial and sensor data; Metadata standards, such as Meaningful Bibliographic Metadata (M2B); Data set compatibility for cross-platform sharing; and Open data access.
Content quality standards	These standards govern the way that agricultural content is controlled for quality and accuracy.	Although not a government standard, the GSMA's <i>mAgri Guidelines for creating agricultural VAS content</i> are a relevant example; and Direct2Farm content management guidelines.
Common terminologies	These enable information that is communicated electronically to make use of a common language across e-agriculture platforms for consistency. A localized thesaurus of agricultural terminologies is critical for localization and portability of content across a country/region.	Agricultural terminology standards, such as AGROVOC.
Secure messaging standards (where necessary)	These are for the secure transmission and delivery of messages and the appropriate authentication of the message receiver, to ensure that information is securely transmitted and delivered to the correct recipient.	Security standards; Network and Interoperability standards; Cloud security standards. For example, ITU-T X Series and Y Series recommendations.

Service interoperability	These define the requirements necessary to conduct various services - such as transactions, information search - across platforms.	Platform-level interconnectivity; and Inter-Cloud interoperability . Financial services interoperability . For example, ITU-T X Series and Y Series recommendations.
--------------------------	--	--

From the e-Agriculture Strategy Guide.

7.1.1 USING METADATA DESCRIPTIONS FOR AGRICULTURE

[Metadata](#) can be used to describe the content and properties of a digital object, such as a document, an image, video, audio, website, database, etc.

The most widely known and used metadata schemes include: the Dublin Core (DC); the [Metadata Object Description Schema \(MODS\)](#); Virtual Open Access Agriculture and Aquaculture Repository [Metadata Application Profile \(VOA3R AP\)](#); and the AGROVOC thesaurus.

DUBLIN CORE

The Dublin Core (DC) is a metadata format that was primarily created for the sake of simple and general [web](#) resources descriptions by authors themselves. The original set of 15 metadata elements was extended and refined within the Open Archive Initiative – Protocol for [Metadata Harvesting \(OAIPMH\)](#) (Open Archive Initiative, 2008). The DC elements describe the most important data and properties of a document (Dublin Core [Metadata Initiative](#), 2010).



2000: Growing the vocabulary

Elements	Refinements	Encodings	Types
1. Identifier	Abstract	Is referenced by	Box
2. Title	Access rights	Is replaced by	DCMIType
3. Creator	Alternative	Is required by	DDC
4. Contributor	Audience	Issued	IMT
5. Publisher	Available	Is version of	ISO3166
6. Subject	Bibliographic citation	License	ISO639-2
7. Description	Conforms to	Mediator	LCC
8. Coverage	Created	Medium	LCSH
9. Format	Date accepted	Modified	MESH
10. Type	Date copyrighted	Provenance	Period
11. Date	Date submitted	References	Point
12. Relation	Education level	Replaces	RFC1766
13. Source	Extent	Requires	RFC3066
14. Rights	Has format	Rights holder	TGN
15. Language	Has part	Spatial	UDC
	Has version	Table of contents	URI
	Is format of	Temporal	W3CTDF
	Is part of	Valid	

Figure 14: source: HLWIKI International

One of the most suitable metadata formats for agriculture is the VOA3R AP. It is partially based on the DC but combined with the AGROVOC thesaurus. As a result, an effective description, availability and automatic data exchange between and among local and central repositories can be attained.

THE AGRICULTURAL INFORMATION MANAGEMENT STANDARDS (AIMS) PLATFORM

[AIMS](#) is a platform for accessing and discussing standards for information management in agriculture, of for tools and methods that connect information professionals worldwide to build a global community of practice.

[AIMS](#) supports a number of projects and initiatives relevant to semantics that: facilitate the provision and exchange of qualitative and interoperable datasets; improve knowledge sharing and reuse; create new collaborative [links](#) in the semantic (in agriculture and beyond) ecosystem; and contributes to sustainable agricultural development.

The strategies developed, promoted and supported by the [AIMS](#) community - to support effective data, information and [knowledge management](#) and exchange - focus on:

- descriptive metadata with open-defined and formatted semantics to support use cases beyond bibliographic indexing;
- open vocabularies, concept systems and other knowledge organization systems (KOS) - example see below AGROVOC;
- Semantic Web models and tools, including linked open data (LOD);
- recommendations and best practices for (meta)data publishing and usage, such as AgMES;
- open (and widely used and globally significant) standards and techniques to facilitate mixing and matching data from different distributed infrastructures and resources.

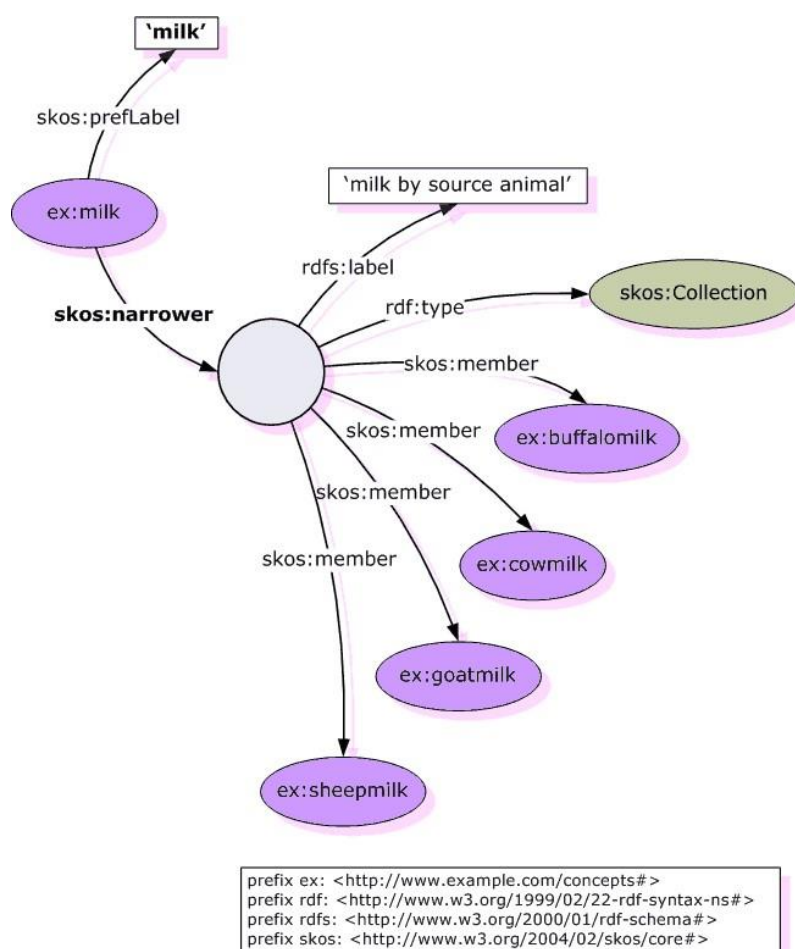

Figure 15: Source: FAO AIMS

THE AGRICULTURAL METADATA ELEMENT SET (AGMES)

AgMES aims to capture issues of semantic standards in agriculture in terms of description, resource discovery, [interoperability](#) and data exchange for different types of information resources.

AgMES as a namespace (an abstract container that holds a logical grouping of unique identifiers) should include agriculture specific extensions for terms and refinements from established standard metadata namespaces such as Dublin Core, AGLS, etc.

It can be used to attach metadata to document-like information objects, such as publications, articles, books, websites, papers, etc. in the field of agriculture in conjunction with the above-mentioned standard namespaces.

AGROVOC VOCABULARY

AGROVOC is a controlled vocabulary covering all areas of interest of the Food and Agriculture Organization (FAO) of the United Nations, including food, nutrition, agriculture, fisheries, forestry, environment etc. It is published by FAO and edited by a community of experts and editors comprising librarians, terminologists, information managers and software developers.

The vocabulary consists of over 35,000 concepts with up to 40,000 terms in 29 different languages - of different coverage (see SKOSMOS). AGROVOC is made available by FAO as an RDF/SKOS-XL concept scheme - which is a data model for structured controlled vocabularies - and published as a [linked data](#) set aligned to 18 other vocabularies.

The AGROVOC thesaurus schema employs three levels of representation:

1. concepts represent abstract meanings and are often identified by URIs, e.g. corn as a cereal is identified by "Concept12332",
2. terms are language-specific forms e.g. corn, maïs, or maize
3. terms integrating special variants, such as spelling variants, singular or plural forms, e.g. hen, hens, cow or cows.

This is how the abstract concepts/terms and the concrete meanings are related. The AGROVOC is therefore suitable for the description of research papers, information or news in the agrarian sector - Agricultural Information Management Standards.

<http://aims.fao.org/activity/blog/agrovoc-thesaurus-some-use-cases>

AGRIS

FAO - AGRIS (International Information System for the Agricultural Science and Technology) is a free of charge service that provides access and visibility to bibliographic data on research papers, reports, [multimedia](#) material, grey literature and other content types in agricultural and related sciences.

AGRIS is using AGROVOC vocabulary.

Watch this video about Open Agris application.



7.2 OPEN DATA

Open data is data that can be freely used, reused (modified) and redistributed (shared) by anyone (Open Knowledge International).



Key features of open data:

- Availability and access: The data must be available as a whole with no more than a reasonable reproduction effort, preferably by downloading over the Internet. The data must also be available in a convenient and modifiable form.
- Reuse and redistribution: The data must be provided under conditions that allow for reuse and redistribution, including intermixing with other data sets.
- Universal Participation: Everyone must be able to use, reuse and redistribute - there should be no discrimination between fields of action or between individuals or groups. For example, "non-commercial" restrictions that would prevent "commercial" use or restrictions on use for specific purposes (e.g. education only) are not allowed (Open Knowledge International).

For data to be considered open, it must be:

- accessible, which usually means published on the internet
- available in a machine-readable format
- with a license that allows anyone to access, use and share them - commercial and non-commercial.

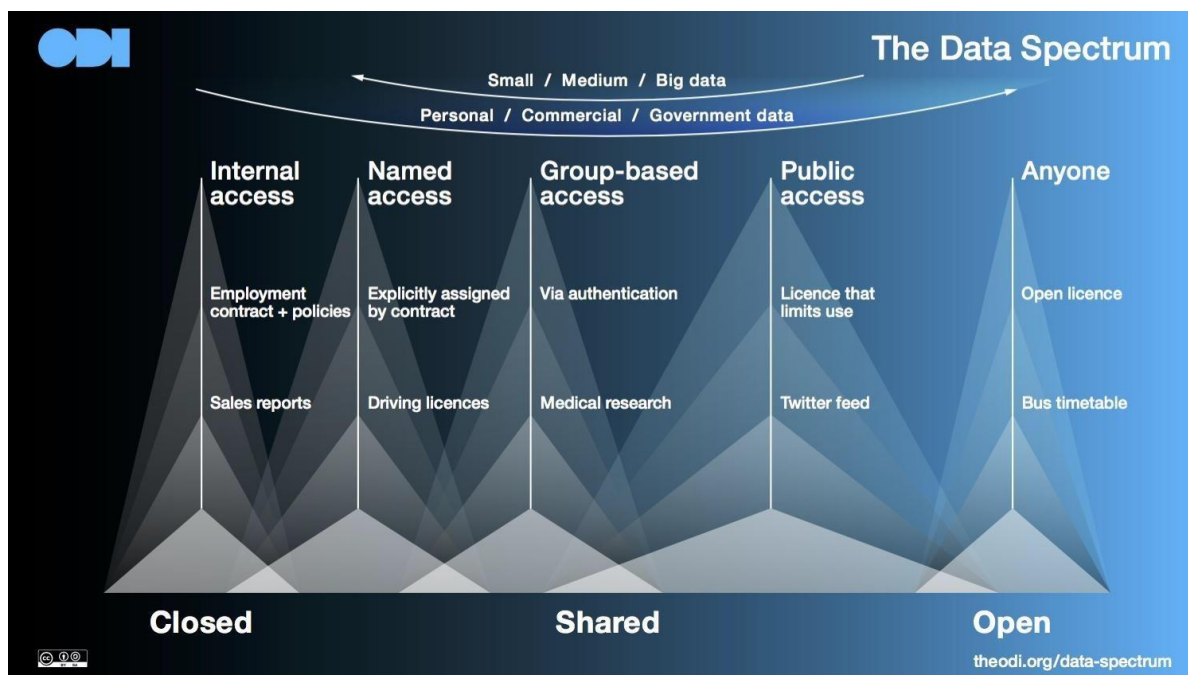

Figure 16: The Data Spectrum by the ODI licensed under CC BY

The data spectrum in the figure above, developed by The [Open Data](#) Institute (ODI), illustrates the degree of openness of data and helps users to understand the language of the data (the [ODI](#)).

Many individuals and organizations collect a wide range of different types of data to perform their tasks. The government is particularly important in this regard, both because of the quantity and centrality of the data it collects, and because most of this government data is public data by law and therefore can be made open and usable for others (Open Knowledge International).

There are many types of [open data](#) that have potential uses and applications:

- Culture: Data on cultural works and artifacts - such as titles and authors - generally collected and kept by galleries, libraries, archives and museums
- Science: data produced in scientific research, from astronomy to zoology
- Finance: data such as government accounts (expenditure and revenue) and information about financial markets (equities, stocks, bonds, etc.) Statistics: data produced by statistical offices, such as the census and the main socio-economic indicators
- Weather: many types of information to understand and predict weather and climate
- Environment: Information related to the natural environment, such as the presence and level of pollutants, the quality of rivers and seas (Open Knowledge International).

7.2.1 FAIR DATA

In 2016, a Nature article "FAIR Guiding Principles for Scientific Data Management and Stewardship" launched the FAIR concept.

FAIR stands for Findable, Accessible, Interoperable, Re-usable principles.

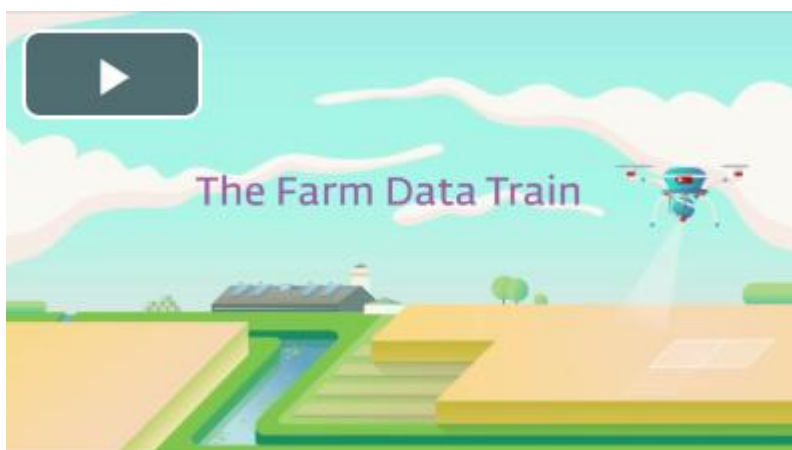

The principles of FAIR Data serve as an international guideline for high quality data management. In the FAIR principles, we use the term "(meta) data" in cases where the principle should apply to both metadata and data.

Although [Open Data](#) and FAIR Data are different, they can be overlapping concepts; FAIR data does not automatically mean that it needs to be accessible - for example, sensitive data may have access restrictions.

7.2.2 LINKED OPEN DATA

[Linked Open Data \(LOD\)](#) is a highly efficient blend of [Linked Data](#) and [Open Data](#), being both [linked](#) and open source at the same time. The benefits of [linked open data](#)

[LOD](#) can connect isolated systems with different formats and reduce the obstacles between different sources. It can support the extension of data schemes and updates of the separate data sets without problems of [interoperability](#). It also makes searching complex data easier and more efficient.

The video shows datasets that have been published in the [Linked Data](#) format.



Figure 17: <https://youtu.be/TXFYSWuEOOw>

7.2.3 FIVE STARS OF OPEN DATA

Linked Open Data five star system

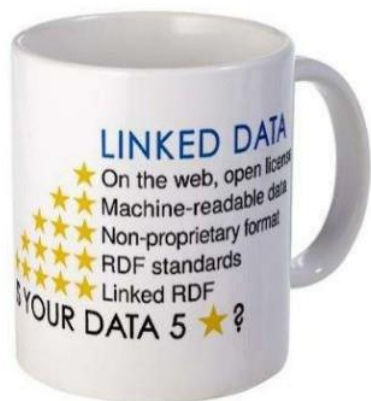

★	Available on the web (whatever format), but with an open license
★★	Available as machine-readable structured data (e.g. excel instead of image scan of a table)
★★★	as (2) plus non-proprietary format (e.g. CSV instead of excel)
★★★★	All the above plus, Use open standards from W3C (RDF and SPARQL) to identify things, so that people can point at your stuff
★★★★★	All the above, plus: Link your data to other people's data to provide context

www.w3.org/designissues/linkeddata.html

Figure 18: Source: <https://www.w3.org/DesignIssues/LinkedData.html>

To score the maximum five stars, data must (1) be available on the [Web](#) under an open licence, (2) be in the form of structured data, (3) be in a non-proprietary file format, (4) use URIs as its identifiers (see also [RDF](#)), (5) include [links](#) to other data sources (see [linked data](#)). To score 3 stars, it must satisfy all of (1)-(3), etc.

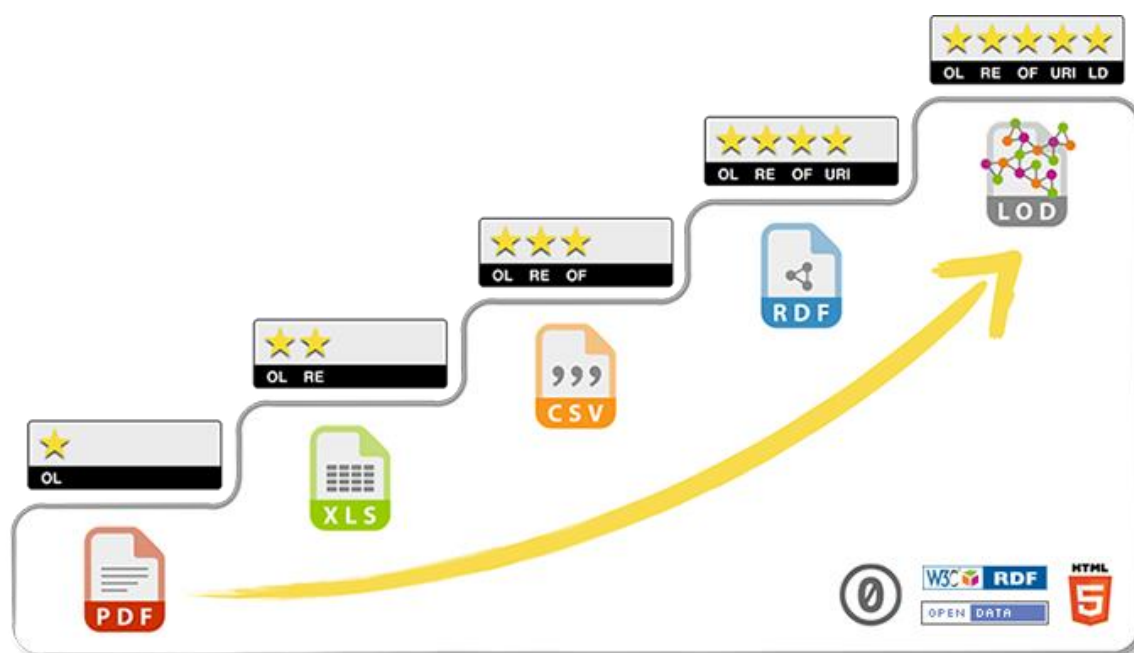

More resources:

- <https://ontotext.com/knowledgehub/fundamentals/linked-data-linked-open-data>
- <https://ontotext.com/knowledgehub/fundamentals/five-star-linked-open-data/>
- <https://lod-cloud.net>
- <https://www.w3.org/DesignIssues/LinkedData.html>
- <http://aims.fao.org/activity/blog/what-and-why-fair-data-easier-said-implemented>
- <http://agrotagger.iitk.ac.in/>

7.3 INTEROPERABILITY

The most commonly used definition of [interoperability](#) is: 'the ability of a system or a product to work with other systems or products without special effort on the part of the user'.

For agricultural context, the [CIARD](#) community (Coherence in Information for Agricultural Research for Development) defined [interoperability](#) for agricultural data as "a feature of datasets ... whereby data can be easily retrieved, processed, reused, and re-packaged ('operated') by other systems."

[Interoperability](#) can be achieved at different levels, for example so called Foundational (such as transmission protocols), Structural (defining formats and syntax of data exchange) and Semantic [Interoperability](#).

Semantic [interoperability](#) which provides [interoperability](#) at the highest level, implies the ability of two or more systems or elements to exchange information and to use the information that has been exchanged. Semantic [interoperability](#) uses both the structuring of the data exchange and the encoding of the data including vocabulary, so that the systems can interpret the data.

At a structural [interoperability](#) level machines understand what different elements are (and their mutual structural relationship), but with semantic [interoperability](#), they also understand the meaning of these elements and can process them with semantic-capable tools to effect advanced deductions.

7.3.1 SEMANTICS FOR INTEROPERABILITY OF AGRICULTURAL DATA

[Interoperability](#), the ability of reusing the data produced by others in your own information system, or vice versa, largely depends on how well and explicitly the 'meaning' of the data is described - semantic [interoperability](#).

There are three initiatives within the [AGRISEMANTICS platform](#) for [interoperability](#) between terminologies in agriculture:

1. Agrisemantics working group within the Research Data Alliance develops a set of recommendations for components supporting semantics.
2. GACS Working Group, a project with [FAO](#), CABI, NAL, working to identify a set of concepts common to their three thesauri ("concept schemes", in [SKOS](#) term). The output is a concept scheme in BETA VERSION.
3. GACS working group is forming a new working group under the umbrella of GODAN. Goal of the group is to enable semantic [interoperability](#) of agricultural data, building on the experience of the previous edition of the GACS working group.

7.3.2 CIARD RING

The [CIARD](#) Routemap to Information Nodes and Gateways ([RING](#)) is a project implemented within the Coherence in Information for Agricultural Research for Development ([CIARD](#)) initiative and is led by the Global [Forum](#) on Agricultural Research ([GFAR](#)).



an infrastructure for
interoperability of agricultural
research information services

The [RING](#) is a global directory of datasets and data services for the agri-food sector. It is the principal tool created through the [CIARD](#) initiative to allow information providers to register their services and datasets in various categories and so facilitate the discovery of sources of agriculture-related information across the world.

The [RING](#) aims to provide an infrastructure to improve the accessibility of the outputs of agricultural research and of information relevant to ARD management.

Functions of the [RING](#)

- to provide a map of accessible information sources with instructions on how they can be used effectively; to provide a dataset sharing platform for the agri-food sector;
- to federate metadata from existing sources whenever possible and alternatively allow for manual submission and curation; to provide examples of services that show good practices on implementing "interoperability";
- to clarify the level and mode of interoperability of information sources;

More info about the [RING](#):

<http://ring.ciard.net/sites/default/files/RING-handbook-updated-2017-09-10.pdf>

7.3.3 FARM MACHINES

One of the biggest problems farmers face is the [interoperability](#) of farming equipment due to different digital standards. This lack of [interoperability](#) is not only obstructing the adoption of new [IoT](#) (Internet of Things) technologies and slowing down their growth in Europe, it also inhibits the gain of production efficiency through [smart farming](#) methods. The IOF2020 project aims to integrate different machine communication standards to unlock the potential of efficient machine-to-machine communication and data sharing between machines and management information systems.

7.3.4 ABOUT APIS, [WEB SERVICES](#)

An application programming interface (API) is a set of protocols for building software. A [Web](#) API is an application programming interface for either a [web server](#) or a [web](#) browser.

Good examples:

- IrriSAT - <http://www.agriteach.hu/en/content/irrisat>
- Agro Api - <http://www.agriteach.hu/en/content/agro-api>

7.3.5 FILE LEVEL INTEROPERABILITY - FILE FORMATS AND CONVERSIONS

Many information systems enable the download of user defined data in different file formats, and also several make it possible for the users to upload files from their own computer to the same or other [online](#) systems. Often file formats used are not the same, so there is a need to convert the data from one file format to the other, in order to make data usable from one system to the other.

Most typical file formats used in agricultural digital applications:

- TXT - this is the simple plain text file format, usually to be opened by Notepad under Windows
- CSV - TXT file with values - representing columns in a table - separated by commas (or semicolons), often used to download or upload tabular data
- XLS - similar tabular (spreadsheet) data like CSV, but Microsoft's own Office format, with added complexity
- PDF - typically used to represent printed, finalized, submitted version of some process, or also for filling out offline e-forms
- HTML - usually these are the content pages of the world wide web, can be directly edited and generated by plain html editors or rich text editors and rendered by Content Management Systems (CMS)
- XML - Extensible Markup Language (XML) is a text format that mainly serves the exchange of a wide variety of data on the Web and elsewhere, for instance in web services, M2M communication, e-Government submissions, etc. It is a tag-based structure (similar to html) with extensible nested elements and attributes.
- XSD - is an XML Schema that describes the structure of an XML document, often used in e-Government services to publish the basic structure and rules of documents and forms.
- SHP - The shapefile format is a popular geospatial vector data format for geographic information system (GIS) software. KML - XML format for Google Maps or Earth, used to display geographic data.
- JSON (JavaScript Object Notation) is a lightweight data-interchange format that is easy for humans to read and write, and for machines to parse and generate, based on a subset of JavaScript Programming Language.
- RDF - It is a standard model for data interchange on the Web having features that facilitate data mapping even if the merged schemas are different, it also supports changing schemas over time without requiring connected schemas and user applications to be changed.

<http://www.fao.org/docs/eims/upload/297074/IECProceedings-main-doc.pdf>

7.4 THE GUIDE

The [FAO](#) and [ITU](#) jointly prepared the [e-agriculture strategy guide and toolkit](#) to provide a methodology and a set of tools to assist countries in developing a national e-agriculture vision, action plan and implementation strategy.

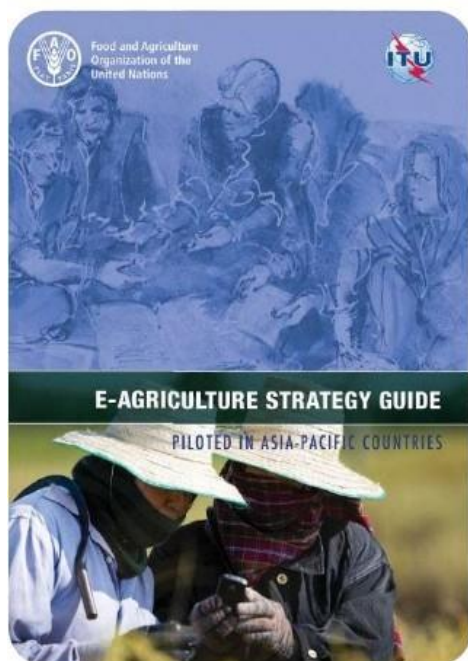

FAO-ITU

E-agriculture Strategy Guide

Available online!

<http://www.fao.org/3/a-i5564e.pdf>

7.4.1 THE STRUCTURE OF THE GUIDE:

PART 1: A NATIONAL E-AGRICULTURE VISION THAT RESPONDS TO AGRICULTURAL AND DEVELOPMENT GOALS

This part develops a national e-agriculture vision that responds to agricultural and development goals. It explains why a national approach to e-agriculture is needed, what a national e-agriculture plan will need to achieve, and how it will be done.

- **Why:** This is the strategic context for e-agriculture, encompassing the agricultural sector growth and demographics, the existing agriculture extension systems, the existing agriculture services, information flow and transaction streams in agricultural value chains, and the resulting implications for e-agriculture.
- **What:** This is the role e-agriculture will play in the achievement of agriculture – sector goals. It serves as a high level message for policy-makers and answers the question of “where does our country want to go with agriculture, and how will e-agriculture help us get there.”
- **How:** This gives the various e-agriculture components – or building blocks – that must be in place to realize the national e-agriculture vision.



PART 2: A NATIONAL E-AGRICULTURE ACTION PLAN THAT REFLECTS COUNTRY PRIORITIES

This part lays out an e-agriculture action plan that reflects country priorities and the e-agriculture context. It structures activities over the medium term, while building a foundation for the long term.

PART 3: A PLAN TO MONITOR IMPLEMENTATION AND MANAGE ASSOCIATED RISKS

This part establishes a plan to monitor implementation and manage associated risks. It shows the progress and the results of implementation and helps in securing long-term support and investment.

8 AGRICULTURAL KNOWLEDGE AND INNOVATION SYSTEMS

The concept of [AKIS](#) was originally defined as the Agricultural Knowledge and Information Systems. The term referred to "a set of agricultural organizations and/or persons, and the [links](#) and interactions between them, engaged in the generation, transformation, transmission, storage, retrieval, integration, diffusion and utilization of knowledge and information, with the purpose of working synergistically to support decision making, problem solving and innovation in agriculture" (Röling and Engel, 1991).

Changing support for agricultural innovations

1980s:

Research institutions

strengthening research supply by providing infrastructure, capacity, management, policy support at national level

1990s:

Links among research, extension, education

still focused on research supply, but more attention to links between research, education and extension and to identifying farmers demand for new technologies (AKIS concept)

AKIS: Agricultural Knowledge and Information System

More recently:

National Agricultural Innovation System concept

Figure 19:Source: FAO

More recently the [AKIS](#) concept has evolved as it has acquired a second meaning (innovation) and the [AKIS](#) was opened up to other public tasks and to the wider support of innovation (Klerkx and Leeuwis, 2009).

Such innovation system is based on a network of organizations, enterprises and individuals focused on bringing new products, new processes and new forms of organization into social and economic use. The system includes interactions with institutions and policies that affect their behaviour and performance.

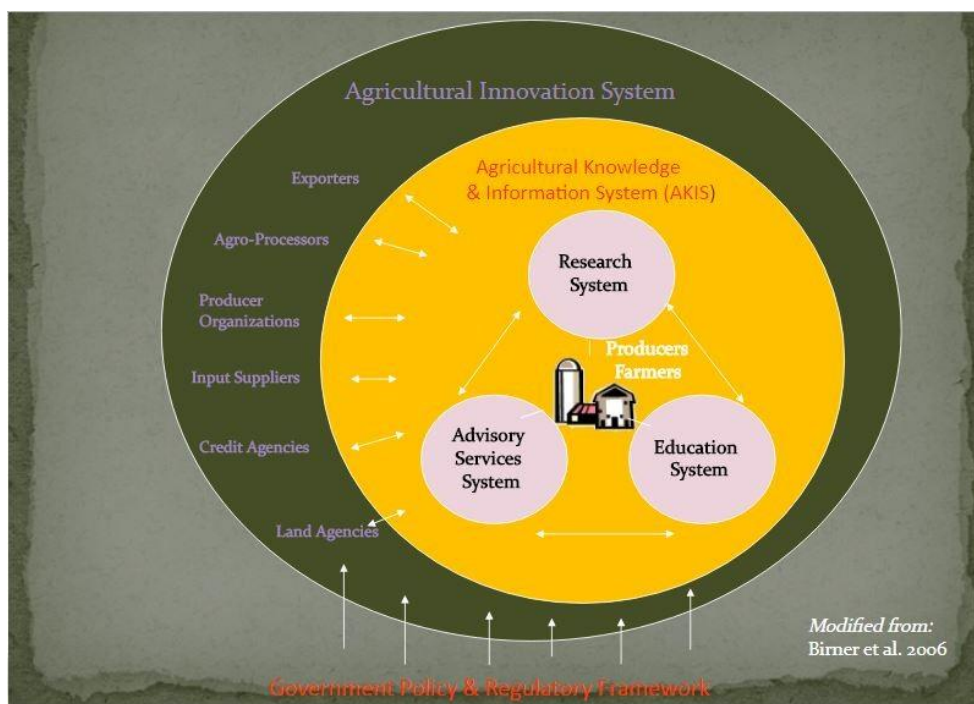

Figure 20: Source: FAO

8.1.1 THE PRO AKIS PROJECT

Prospects for Farmers' Support : Advisory Services in European [AKIS](#) (PRO [AKIS](#))

PRO [AKIS](#) had the following objectives:

- Develop a conceptual framework for the assessment of AKIS
- Provide an inventory of the AKIS institutions & interactions in the EU-27 as a searchable database Using case studies, investigate challenges around:
 - small-scale farmers' access to relevant & reliable knowledge
 - bridging scientific research topics & farmers' demands
 - offering appropriate support for diverse rural actors that form networks around innovations in agriculture & rural areas
- Reveal successes, strengths & weaknesses of the specific knowledge systems through comparative analyses & assessments of these case studies
- Develop policy recommendations for strengthening European agricultural innovation systems

The Inventory of [AKIS](#) in Europe is available from the [EU ProAKIS](#) project

- Results: http://proakis.webarchive.hutton.ac.uk/sites/www.proakis.eu/files/AKIS_characterisation_briefing_final.pdf
- Country reports are useful documents that offer insights into [AKIS](#) for the member states: <http://proakis.webarchive.hutton.ac.uk/inventory/country-reports-%E2%80%93-inventory-akis-and-advisory-services-eu-27>
- Further reading: https://ec.europa.eu/research/scar/pdf/akis-3_end_report.pdf

8.2 FARM ADVISORY SERVICE IN THE EU

Rural development policy supports farmers in the use of advisory services and helps Member States set up new farm advisory services where necessary.

The 2003 [CAP](#) reform introduced the Cross Compliance Mechanism, which provides direct payments for compliance with basic environmental, food safety, animal and plant health and animal welfare standards by farmers, and the preservation of good agricultural and environmental land conditions ([GAEC](#)).

Video about cross compliance checks:



The introduction of this mechanism resulted in an obligation for Member States to set up an agricultural advisory system to help farmers better understand and comply with [EU](#) environmental, human and animal health, animal welfare and [GAEC](#). In this context the national authorities had a duty to offer advice to their farmers under an [FAS](#) (Farm Advisory System), using, where appropriate, certain priority criteria (Council Regulation 73/2009).

The farm advisory system covers the whole organization and the various public and / or private operators who provide farm management services to a farmer in a Member State (see Article 12 of the Council Regulation).

The existence of a national [FAS](#) guarantees that every farmer can seek and obtain advice, at least as regards the essential cross compliance requirements in the areas of environment, public health, animal and plant health, animal welfare and [GAEC](#). An operating consultancy assesses the specific situation of the farmer and gives appropriate advice.

Therefore it is not optional for a member state to decide whether to have such system in place or not, but in fact it is rather obligatory by the law for each member country to set up and operate a national Farm Advisory System.

However, how this network is set up and managed, differs largely country by country.

8.2.1 EUFRAS

[EUFRAS](#) is a European network and representative association of public and private rural and agricultural extension services which is aligned to the global representative body for advisory services [GFRAS](#) with associations set up in many other continents.

8.2.2 SEASN

South Eastern Europe Advisory Service Network – SEASN is an association of agricultural advisory services, agricultural chambers, agricultural institutes, faculties and non-governmental organisations, operating on the territory of its members: Austria, Bulgaria, Croatia, Hungary, Kosovo, Macedonia, Montenegro, Romania, Serbia and Slovenia.

<http://seasn.eu>

More resources:

- https://ec.europa.eu/agriculture/direct-support/cross-compliance/farm-advisory-system_hu
- https://ec.europa.eu/eip/agriculture/sites/agri-eip/files/20180426_ws_latvia_pres03_akis_inge_van_oost.pdf
- <https://ec.europa.eu/eip/agriculture/en/event/eip-agri-workshop-enabling-farmers-digital-age>
- <https://ec.europa.eu/eip/agriculture/en/news/knowledge-systems-farmers-eu>

8.3 ICTS IN FARM ADVISORY SERVICES

These are examples of the most frequently used [ICT](#)-supported agri-services in Hungary. The first six include [ICT](#) components used in the provision of the service:

- 32% Farm management software „farmer's diary" (logbook)
- 13% Soil nutrition / fertilization plan
- 9% Land ownership, land use, consolidation 6% Legal regulations monitoring
- 5% e-Claim for land based subsidy
- 2% Plant protection plan and administration
- 2% Technological advice

8.3.1 INTEGRATED ICT-ASSISTED FARM ADVISORY SERVICE - SYSTEM DESIGN

A conceptual model of a farmer's single window, [ICT](#)-assisted farm advisory system was designed for a Western Balkan scenario, and based on [EU](#) experience.

An information system model was developed within an [FAO](#) supported project, based on good and proven practices from [EU](#) countries. The model recommended the set of modules depicted below. Highly and inter-operable, they are able to fully support the members of [AKIS](#) - particularly farmers, advisors and government actors - and raise the effectiveness of their use of financial tools (including grants, subsidies, credit lines, bank guarantees, etc.) for greater efficiency in farming and rural development measures. They help take the financial inclusiveness of farmers to a higher level.

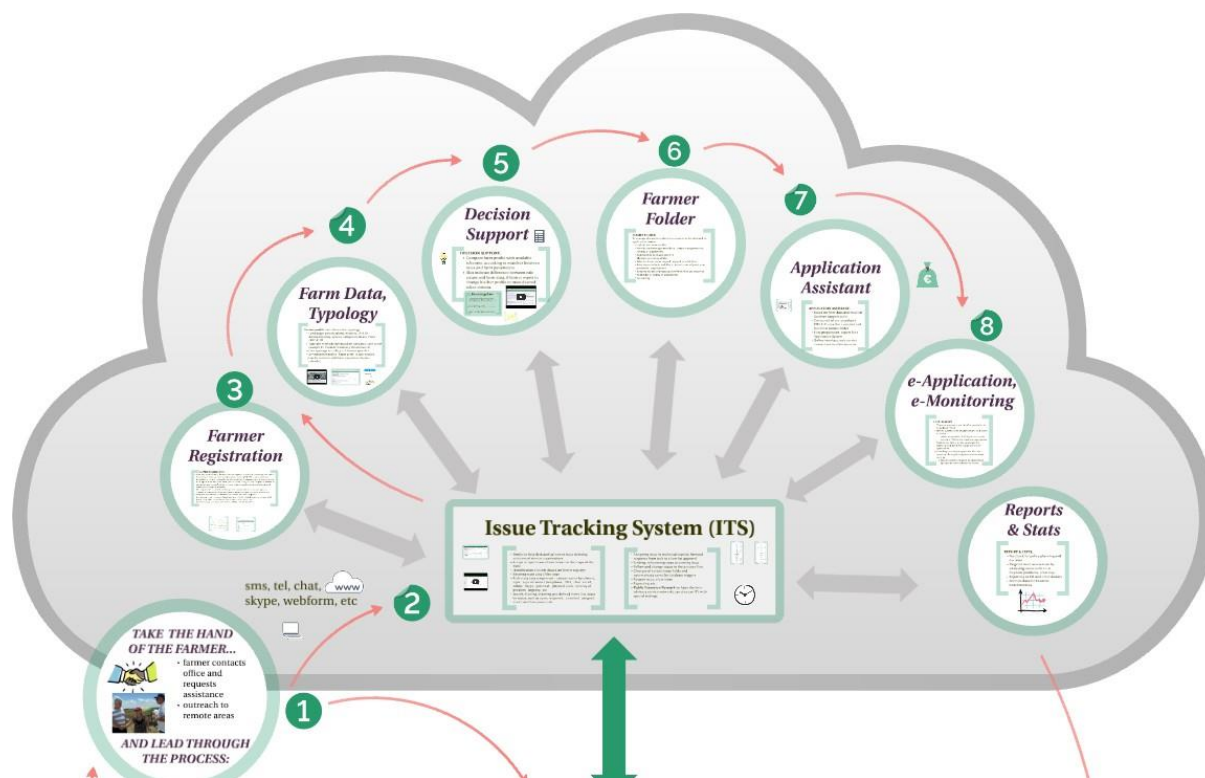

Main modules:

- Issue tracking system
- Client database (farmer register)
- Farmer profile (farm data, farm classification by standard typology) Decision support rule base & document repository
- Farmer folder Application compiler Reporting

8.3.2 ISSUE TRACKING SYSTEM

This central module records, tracks and reports issues and their related communication with clients and experts. It is the centre of the ISP system, assisting with the full life cycle of the process - from the point of first contact between the farmer and service point staff, public extension agents or farm advisers - through to the monitoring and evaluation of the service.

This sub-system can also play a role in serving the data management and administration purposes of the advisory service networks - public and licensed private - communicating with these external services via defined service points.

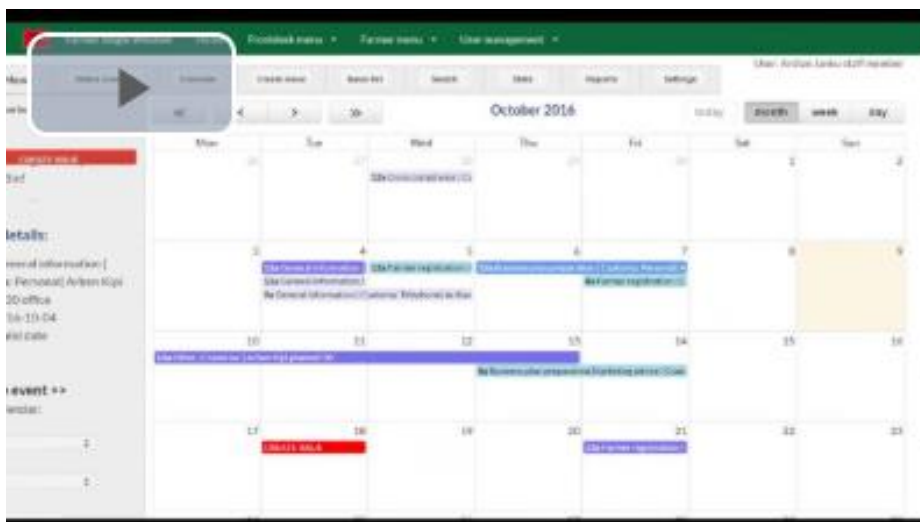

The issue tracking system (ITS, or also known as a Request Management System) is commonly a computer software package that manages and maintains lists of issues, as needed by the organization. Such systems are frequently used in organizations' [client](#) support call centres to create, update, and resolve reported customer issues, or even issues reported by that organization's internal employees. An issue tracking system generally comprises a knowledge base containing information on each customer, resolutions to common problems, and other similar data, and functions in a similar way to a 'bugtracker' (often bugtrackers are capable of being used as an issue tracking system.) A 'ticket' within the issue tracking system is used to create and track a running report on a particular problem, report on its status, and supply other relevant data.

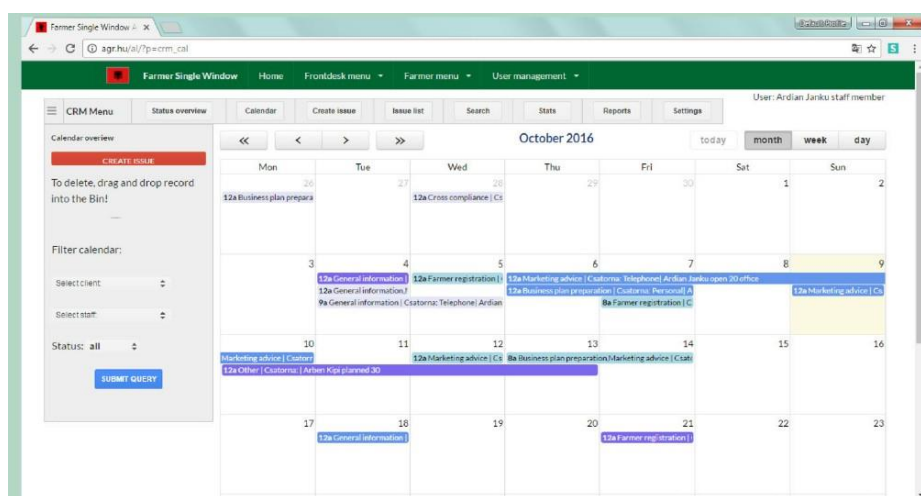

Tickets are commonly created within in a help desk or call centre environment, and almost always have a unique reference number (also known as a case, issue or call log number) which is used to allow the user or help staff to quickly locate, add to or communicate the status of the user's issue or request.

Main functional requirements of the ITS:

- Accept or reject issues (if not related to the functional domain of the system) Identification of a client (based on farmer registry)
- Data entry for an issue, ideally tagged with rich meta data, e.g. categorized by scheme, topic, type of contact (telephone, SMS, chat, email, online, Skype, personal - physical visit), severity of problem, urgency, etc.
- Searching, filtering, ordering, pre-defined views (list issues by status, such as open, reopened, unsolved, assigned to etc.) and free query tools

- Assigning issues to technical experts, and forwarding responses to clients for approval Linking and referencing new issues to existing one
- Tracking and updating statuses within the process flow
- Storing and recording changes to issues, triggering database functions, and generating issue histories (change logs) Reopening issues and closing issues
- Reporting

Public Extension Network - farm advisory service network – experts should have access to the ITS with the necessary user permission settings for their needs.

8.3.3 CLIENT DATABASE / FARMER REGISTER

An official farmer register must be maintained according to national rules of registration, but also meeting [EU CAP](#) requirements. The rules should include: the regulation of the conditions of granting agricultural support from agricultural and rural development funds; and the rights and obligations of both the applicants and the authorities involved in implementing agricultural and rural development support measures.

8.3.4 FARM PROFILE

Based on [EU](#) and national methodologies, farmers are classified according to reference groups (activity type and size) which enables the system to feed back relevant and even personalized information to them. For example:

- Farmer profiles can be generated by matching farm and farmer data with farm typology
- Farm data may include crop production, land usage, parcels, plants, size of area (ha), LPIS ID
- Animal breeding, species, subspecies, heads, flock (RUDA) ID, typology, and methodology, based on standards such as the EU Farm Accountancy Data Network

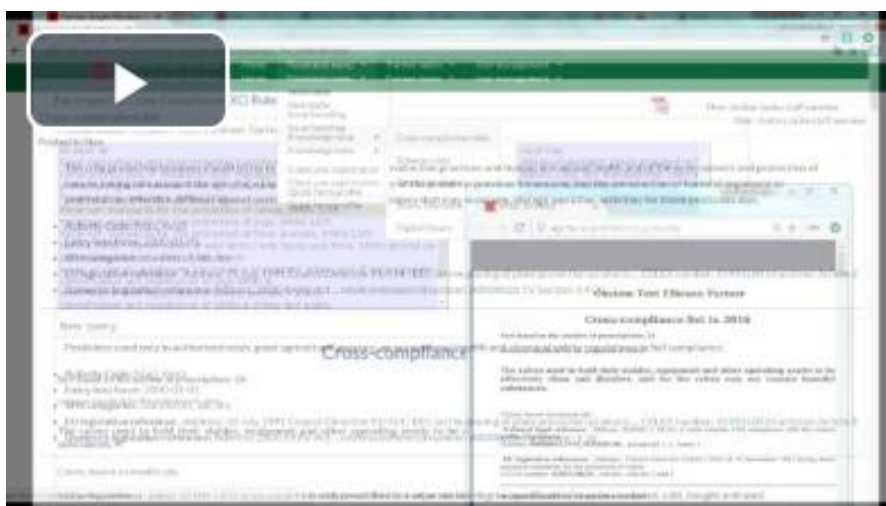

There is no single structure. For example, the structure of Albanian agriculture is very different from the [EU](#) average so it is advisable to use their specific national typology - one has been recently introduced by AUT in JRC study.

Once a profile is produced, it can then be saved as a sort of 'finger print' for that specific user and used within their ITS sessions. Profiles can become quite accurate, particularly if integrated and used in conjunction with specific farm operations, for example a farmer calendar.

Actual farmer crop and livestock data , including details the varieties and amounts (hectares, heads), should be used and compared to European Size Units (EUSU). This data should ideally be updated when changed, though more likely updated annually.



8.3.5 DECISION SUPPORT

This module supports financing functions and opportunities, including the management of grants and other subsidies for investment projects and other agricultural activities. It uses 'matching rules' based on farmer profiles alongside farm typology results, so it depends on accurate farmer profiles (see above) and related knowledge base structures. The system should also be able to list available schemes matching specific parameters, conditions and expectations of the farmer.

Decision Support

DECISION SUPPORT:

- Compare farm profile with available schemes, according to matches between rules and farm parameters.
- Also indicate difference between rule values and farm data, if farmer wants to change his/her profile to meet desired schee criteria.

KnowledgeBase

... ..

8.3.6 KNOWLEDGE BASE

Representation of business rules, i.e. applications criteria, should be described in standard and structured formats (XSD, XSLT, RuleML etc.) to be processed by the relevant IT systems. Business rules can be extracted from scheme regulations and related information contained in guides, forms, annexes, etc.

Types of knowledge base information include:

- Basic and special eligibility criteria, competitiveness rules
- Farm typology feedback, cross compliance rules, financial reference data for business plans, filtered searches Documents (regulations, guides, applications, annexes, forms, etc.), annexes, and links to digital libraries Description of use cases, paths with process diagrams illustrating how to arrange different case types
- Manuals about related procedures (TIN registration, etc.) Catalogues of eligible farm machinery
- Construction norms and rules
- Connections to Advisory Platforms for other information, e.g. marketing, technology, risk forecasts (weather, pests) etc. General functions: categorization, keywords, archiving, update history, full-text search
- Use of FAO AgMES, AGROVOC or EUVOC metadata standards

8.3.7 FARMER FOLDER

In many cases the same documents are required to be attached to different application dossiers, so it is advisable to save scanned copies of such documents to be used in each farmer [client](#)-component of the system, i.e. available for reuse in different applications. The main functional requirements of the Farmer Folder therefore includes:

- Uploading and removing files Providing and managing metadata Simple categorization
- Managing the validity of documents De-activating expired files
- the multiple selection of files
- Selecting files to be copied, and zipped to subfolders
- Attaching selected files to submissions of particular proposals and applications Keeping record of proposals to which files are attached
- Reminders of the expiry of documents versioning

8.3.8 APPLICATION ASSISTANT

This module enables the export of farm and farmer data to different formats and structures. It is used, for example, for interactive PDF application form inputs, for uploading documents to other [online](#) systems, or to provide [online](#) interfaces to other services such as electronic claim submissions. Its main features include:

- Building on farm data and results from decision support tools
- Developing submission packages based on pre-populated PDF X-Forms and files from within the Farmer Folder
- Compiling files for export to e-Application Systems
- Using online interfaces and web service connection to other services

8.3.9 E-APPLICATION:

These components are expected to be provided by [IACS](#) for:

- online submissions of applications and claims to ARDA,
- connections to systems via server-server interfaces (WS) or file level interoperability, enabling the tracking by the applicant of the approval and payment status of applications,
- providing data by the applicant after the approval, and during the implementation stage, e.g. monitoring information or special farm operations to be reported to ARDA.

8.3.10 REPORTS AND STATISTICS

This module provides statistical information, charts, graphs including:

- Feedback for policy planning and decision making
- Targeted needs assessment, e.g. by analysing issues with most frequent problems, error logs. Reporting to the EU and other donors
- Sectoral data for financial benchmarking.

Resources:

- <https://prezi.com/pgcsiidroteb/farmer-single-window-preview/>
- <http://www.fao.org/e-agriculture/blog/icts-and-agricultural-extension-services>
- <http://aewb-ict.net/project-outcomes/>

8.4 THE VERCON MODEL

The Virtual Extension and Research Communication Network ([VERCON](#)) is a conceptual model developed by [FAO](#). Any country can use and adapt it to make effective use of up-to-date information and communication technologies serving the professional needs of research, education and extension communities, thus contributing also to agriculture and rural development in the country.



The model aims at improving access to agricultural information and knowledge sharing, and at supporting [linkages](#) among all the stakeholders, using new Information and Communication Technologies (ICTs) to create greater opportunities for collaborative work.

Since 2000 [FAO](#) has been supporting knowledge and communication systems based on the [VERCON](#) model in several countries throughout five regions: Africa, Asia, Middle East, Latin America, and Central and Eastern Europe.

Source: <http://www.fao.org/nr/research-extension-systems/areas-of-work/tools/vercon/en/>

8.4.1 THE CHALLENGE

Strong [linkages](#) between agricultural research and extension are essential for research to successfully contribute to agricultural and rural development. Similarly, access by small farmers and their organizations to information and knowledge on appropriate agricultural technologies is fundamental

for improving their competitiveness, and their contributions to food security and sustainable development.

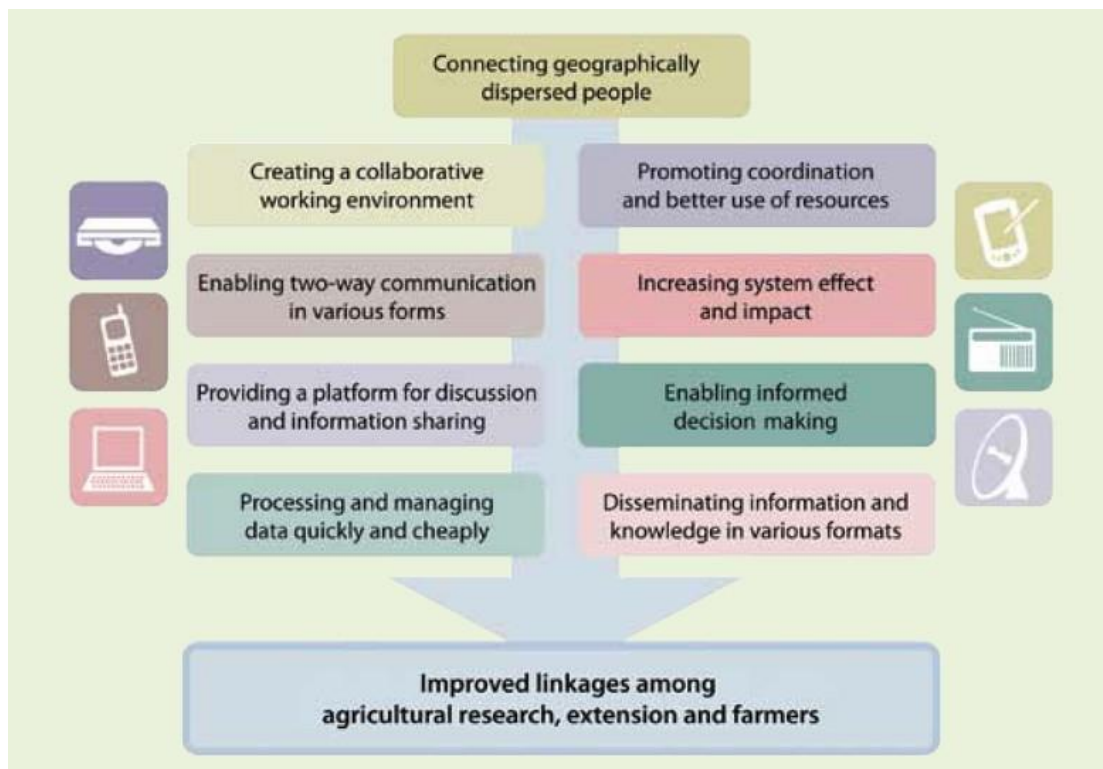

Figure 21: Source: FAO VERCON

Several attempts had been made in the past at improving the [linkages](#) between the research & extension components and the farmers, for example:

- through outreach research and on-farm trials by creating inter-disciplinary committees
- by placing extension staff at research institutes
- by bringing together research and extension under the same administration

However, these efforts proved to be relatively ineffective. The challenge of the [VERCON](#) model is therefore to improve access to agricultural information and enhance communication, knowledge-sharing and lesson learning among and within the human, institutional and social components of agricultural production systems. This will be achieved by creating opportunities for collaborative work, using innovative methods of communication and new information and communication technologies (ICTs), and addressing the needs and priorities of the farmer communities as a major concern.

8.4.2 WHO IS INVOLVED

Sharing knowledge and improving communication and information involves a variety of actors within countries. In addition to the farming community, potential stakeholders of [VERCON](#)-style systems include institutions and individuals in the fields of agricultural research, extension, education and policy, as well as the media, i.e.:

- Extension and advisory services (specialists in various fields) Researchers (staff of agricultural research centres)
- Farmers (social groupings of rural people, grassroots communication networks, youth groups, pioneer farmers, agricultural businesses, male/female/mixed farmers' associations)

- Governmental sectors (staff of Ministry of Agriculture and/or related Ministries) Non governmental sectors (NGOs)
- The private sector (support, input services, traders) The education sector (university researchers)
- Communication professionals and the media (e.g. rural radio stations)

8.4.3 THE APPROACH

The [VERCON](#) approach brings together two fully integrated and inter-dependent dimensions that need to be combined appropriately: the human and the technological.

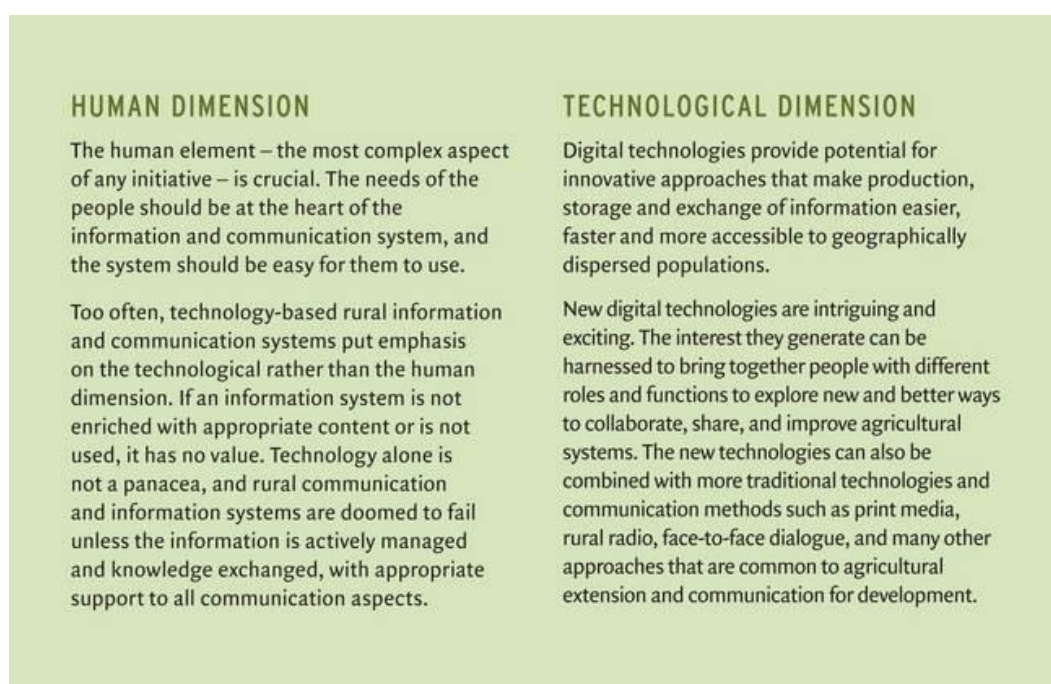

Figure 22: Source: FAO VERCON

The [VERCON](#) process is the glue that holds the system together.

WORKING DIFFERENTLY

Planning, building and maintaining networks require continuous human, financial and management commitments from all stakeholders. The process brings people together to re-think how they currently communicate – and how they could communicate better.

COLLABORATION AND COMMUNICATION

A [VERCON](#)-style system is the outcome of extensive collaboration among agricultural stakeholders who address challenging questions about existing communication processes while seeking to improve their country's agricultural information system. What is unique about the [VERCON](#) model is its ability to bring together people from different institutions, and at different levels within those institutions, to work within a more collaborative, less hierarchical structure.

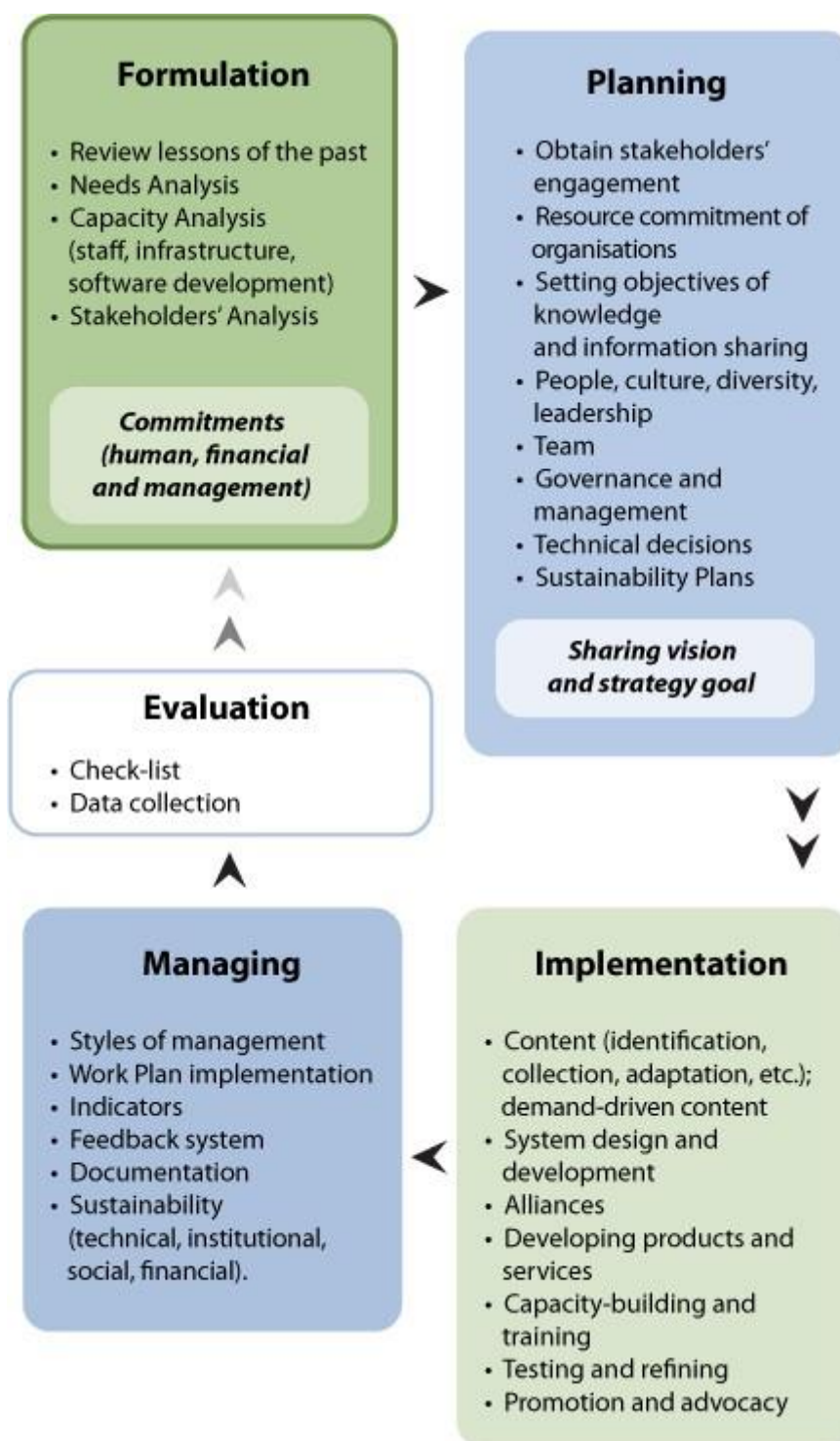

Figure 23: Source: FAO VERCON

FURTHER READING: BUILDING ELECTRONIC COMMUNITIES AND NETWORKS

This [E-learning](#) module is designed to develop the strategic, interpersonal and technical skills needed to build and manage electronic communities and networks (from the series of [e-learning](#) modules developed as part of the Information Management Resource Kit (IMARK)).

http://www.imarkgroup.org/modulelist_en.asp

SUCCESS FACTORS

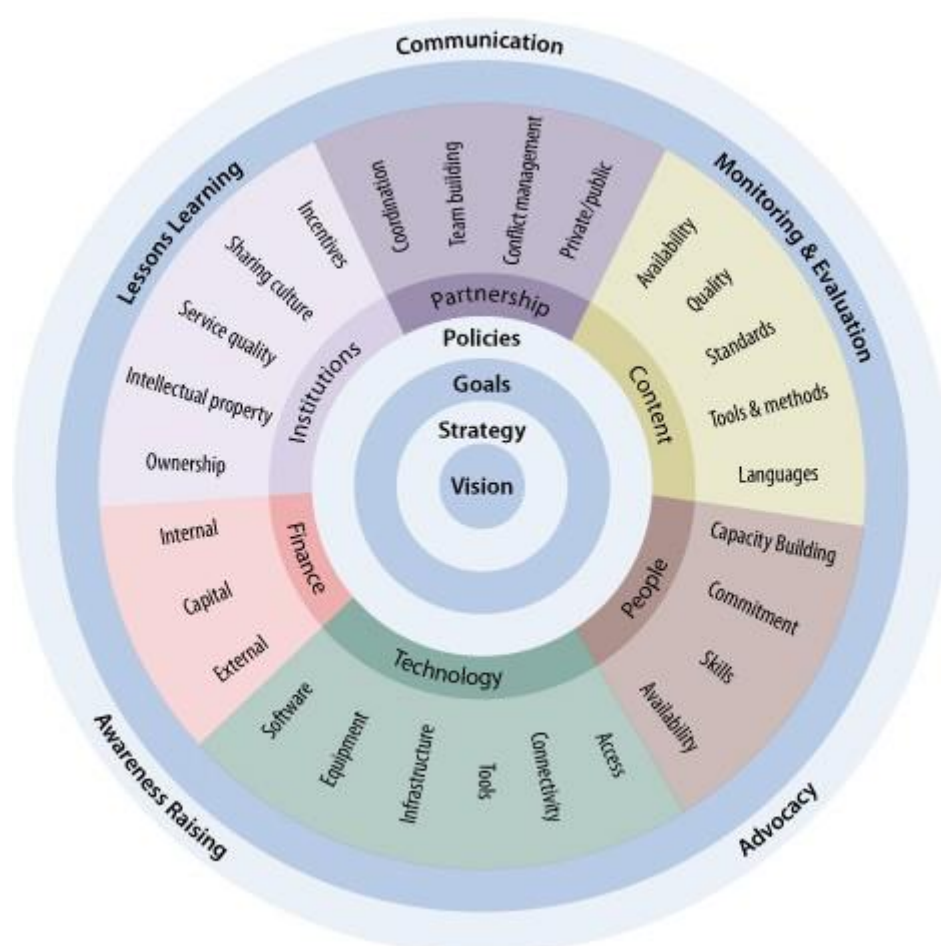

Figure 24: Source: FAO VERCON

Successful implementation of the [VERCON](#) model requires particular attention to be paid to a series of critical factors.

The inner rings show that a common vision and strategy, as well as shared goals and policies, need to be established among network members at the very start of the process. A shared vision and strategy needs to be at the centre of the system to make it work.

The outer rings illustrate the importance of ongoing processes - such as monitoring and evaluation of the information and communication system, and lesson learning - with public support and recommendation of a particular policy, communication and promotion activities guaranteeing support within the network at all levels and commitment from the participating organisations.

In addition to these, other critical factors have been identified in six interrelated categories: people, technology, finance, institutions, partnership and content, as follows:

- **People.**
There should be sufficient human resources with appropriate skills to carry out the requested

tasks, and people need to be committed to the project. Opportunities must be created to develop the capacities of all stakeholders so that they feel comfortable with any proposed changes.

- *Technology.*
Ensuring access to the system by all users is not a challenge, it is a must. A capacity assessment will identify the system's limitations in terms of connectivity, infrastructure and equipment. The system needs to be built in collaboration with the users, and must adopt a realistic approach to technology. The technology should serve the users and not the contrary. If people are not comfortable with the system, they won't use it!
- *Finance.*
As several institutions are usually involved in a [VERCON](#)-style system, the cost of building the network should be shared and respected. The budget will take into account the cost of equipment, travel, repackaging of content, maintenance, organization of meetings at apex and decentralized levels, etc. Funds can originate from various sources: internal, external and partnerships.
- *Institutions.*
Implementing the [VERCON](#) model is part of a process of institutional strengthening, in terms of management, commitment, incentives, knowledge-sharing culture and service quality. Ownership among the partners and within the institutions involved is fundamental, as well as an enabling environment conducive to knowledge sharing. The importance of intellectual property and the issue of individual contributions will also need to be recognized and addressed.
- *Partnership.*
Diverse partners are involved in implementing [VERCON](#). A "win-win" approach will ensure that all partners benefit. Team-building exercises will also stimulate joint problem solving and help the network partners develop their capacity to work together effectively.
- *Content.*
Without content there is no system. Whether digitized or not, a good information management system should be put in place. The system should include the adoption of standards and peer reviews to guarantee the quality of content, as well as tools and methods for searching and retrieving documents. Content will need to be adapted to the local context and different users, in terms of language (national and local languages, level of complexity, illustrations, etc.) and formats (written document, audio, video, image, etc.).

8.4.4 CONCEPTS AT A GLANCE

A better understanding of the virtual communication and knowledge systems implies reviewing a few key concepts. These are notably:

- *ICTs - Information and Communication Technologies.*
The technologies used to handle information and aid communication. These include hardware, software and media for the collection, storage, processing, transmission and presentation of information in any format (i.e. voice, data, text and image): computers, the Internet, CD-ROMs, e-mail, telephone, radio, television, video and digital cameras, etc.
- *New ICTs - New Information and Communication Technologies.*
These are digital and under constant evolution, hence the qualifier 'new'. New ICTs are generally networked via the global Internet and/or telecommunication networks. They can include mobile phones, personal computers, personal data assistants (PDAs), and the Internet and its myriad applications (interactive websites, [online](#) communities, virtual libraries, electronic

publications, electronic mail, [online](#) databases, video conferences).

- *Rural Digital Divide.*
The rural digital divide is the term used to describe the unequal access to Information and Communication Technologies (ICTs) between rural and urban areas. It prevents rural populations from accessing information sources and knowledge available throughout the world.
- *Gender and ICTs.*
Rural women and girls usually have less access than men to information and to new technologies. Without equal access to information, they are at a disadvantage in making informed choices about what to produce and when to sell their products. Lack of information also limits their influence in their communities and their ability to participate in decision-making. On the other hand, if women gain access to information technologies, they can benefit from increased educational opportunities and channels for better networking.

Globalization and new information technologies are transforming the way that production is organized and information shared around the world. These changes could accelerate progress toward gender equality. But unless researchers and policymakers and communities themselves give attention to gender when considering the opportunities and risks, and unless women have a voice in how these new technologies are developed and deployed, the new technologies could very well exacerbate existing inequalities.

Further reading:

- FAO, Gender and ICTs: <ftp://ftp.fao.org/sd/SDW/SDWW/COAIM-paper-final.doc>
- Harnessing ICTs for Advancement of Rural Women: FAO Perspectives and Strategic Actions. See <http://www.un.org/womenwatch/daw/egm/ict2002/reports/Paper%20by%20FAO.PDF>
- Asian Regional Expert Consultation : Rural Woman in Knowledge Society. See <ftp://ftp.fao.org/docrep/fao/006/ad450e/ad450e00.pdf> Dimitra Project, an FAO information and communication project to empower rural populations and increase the visibility of rural women and their contribution to food security and sustainable development. <http://www.fao.org/sd/Dimitra/>
- GenderIT.org: changing the way you see ICT - <http://www.genderit.org/en/index.shtml>
- Information management
This covers the various stages of information treatment: producing, collecting, processing, storing, classifying, and disseminating information; information can be presented in different formats and originate from different sources.
- Knowledge management.
This is the systematic process of finding, selecting, distilling, presenting, organizing and storing information in a way that improves its comprehension.
- *Communication for development (ComDev)*
This approach is based on the premise that successful rural development calls for the conscious and active participation of the intended beneficiaries at every stage of the development process. Rural development cannot take place without changes in attitudes and behaviour among the people concerned. Communication for Development is defined as the planned and systematic use of communication, through inter- personal channels, ICTs, audio-visuals and mass media. It combines participatory communication methods and processes with a variety of tools ranging from local media and traditional social groupings, rural radio, videos and [multimedia](#) modules for training farmers to ICTs. The planned use of communication techniques, activities and media expose people to change and give them a greater say in decisions that affect their lives. See http://www.rdfs.net/themes/communication_en.htm, and <http://www.km4dev.org/>

8.4.5 PLATFORMS RELATED TO THE VERCON MODEL

- *e-Agriculture*
A global initiative supported by different partners, including [FAO](#), to enhance sustainable agricultural development and food security by improving the use of information, communication, and associated technologies in the sector. <http://www.e-agriculture.org/>
- *Technology for Agriculture (TECA)*
Aiming to support the documentation and dissemination of proven technologies, this [web](#)-based initiative for a network of decentralised databases or repositories uses a standard field structure to describe technologies, for easy information exchange between repositories. <http://www.fao.org/teca/>
- *FAO Research and Extension Site*
Illustrate [FAO](#) work to improve national systems by supporting the organization and management of national agricultural research systems, providing assessment, policy advice and assistance to reorienting extension services and facilitating and promoting [FAO](#)'s participation in international initiatives and efforts in agricultural research and extension. <http://www.fao.org/nr/research/res-home/en/>
- *FAO Agricultural Market Information Services*
Market information is crucial to enable farmers and traders to make informed decisions about what to grow, when to harvest, to which markets produce should be sent and whether or not to store it. [FAO](#)'s Marketing Group is active in promoting efficient and sustainable market information services in member countries. <http://www.fao.org/ag/ags/agricultural-marketing-linkages/market-information-services/en/>
- *TISUP*
TISUP is the system of centralized and regular data collection concerning the market of agricultural food products, along with the distribution of the obtained relevant market information to the market participants. The emphasis is on the data and information regarding the prices of agricultural food products in order to ensure a permanent market survey. <http://www.tisup.mps.hr/onama.aspx>
- *SARNISSA* is an [EC](#) funded project aiming to [link](#) individuals throughout Sub Saharan Africa and beyond, on issues related to African aquaculture, building on an existing knowledge resource base and exchange platform – The Aquaculture Compendium. <http://www.sarnissa.org/tiki-index.php?page=About%20the%20project>

8.5 MODULE 2 GLOSSARY

A

AgMES - the Agricultural Metadata Element Set (AgMES) aims to encompass issues of semantic standards in the domain of agriculture with respect to description, resource discovery, interoperability and data exchange for different types of information resources.

AGRICULTURE 4.0 - the slogan 'Agriculture 4.0' draws on the term 'Industry 4.0' and refers to increased integration of IT and communications technology with agricultural production. Using smart, networked systems combining various different types of data from multiple sources promises to increase productivity and efficiency. Another feature is the increase in transparency along the value chain. It is not just agriculture that benefits, but also the environment and downstream economic activities right down to the end consumer. The model for the future is a fully automated and autonomous agriculture.

AIMS - Agricultural Information Management Standards

AKIS - Agricultural Knowledge and Innovation SystemARD

B

BIG DATA - extremely large data sets that may be analysed computationally to reveal patterns, trends, and associations, especially relating to human behaviour and interactions. Data sets can be so big and complex that traditional data-processing application software are inadequate to deal with them

C

CAP – Common Agricultural Policy of the EU

CIARD - Coherence in Information for Agricultural Research for Development (ARD)

CMS - Content Management Systems

CROSS-COMPLIANCE - a principle of CAP where there is a link between receipt of CAP support by farmers in respect of a set of basic rules related to the main public expectations on environment, public and animal health, as well as, animal welfare.

D

DIGITAL AGRICULTURE - Digital Agriculture, or Digital Farming, involves going beyond the mere presence and availability of data to create actionable intelligence and meaningful added value from such data.

DSM - Digital Single Market (Strategy)

E

E-AGRICULTURE - ICT4Ag, or e-agriculture, is the use of Information and Communication Technologies (ICTs) in the agricultural sector. It can encompass all ICTs that are/can be used in the field of agriculture, and which range from older technologies like video, radio and television to computing, internet, remote sensing, mobile and digital broadcasting

EC - European Commission

EIP - European Innovation Partnership

EIP AGRI - European Innovation Partnership for Agricultural productivity and Sustainability (EIP-AGRI)

EO - Earth observation is the gathering of information about the physical, chemical, and biological systems of the planet via remote-sensing technologies. https://en.wikipedia.org/wiki/Earth_observation

ESA - European Space Agency

EU - European Union

EUFRAS - European network and representative association of public and private rural and agricultural extension services

F

FADN - Farm Accountancy Data Network

FAO - Food and Agriculture Organisation

FAS - Farm Advisory System in the EU

G

GAEC - Good agricultural and environmental conditions

GFAR - Global Forum on Agricultural Research

GFRAS - Global Forum for Rural Advisory Services

GIS - Geographic Information System: a system designed to capture, store, manipulate, analyze, manage, and present spatial or geographic data

H

H2020 - Horizon 2020 – the flagship EU Research and Innovation programme

I

IACS - Integrated Administration and Control System

ICT - Information and Communication Technology agriculture, and which range from older technologies like video, radio and television to computing, internet, remote sensing, mobile and digital broadcasting

INTEROPERABILITY - is a capability of a product or system, whose interfaces are completely understood, to work with other products or systems, without any restrictions.

IoT - Internet of things. The Internet of Things (IoT) is the network of physical devices, vehicles, home appliances, and other items embedded with electronics, software, sensors, actuators, and connectivity which enables these things to connect and exchange data, creating opportunities for more direct integration of the physical world into computer-based systems, resulting in efficiency improvements, economic benefits, and reduced human exertions.

ITU - International Telecommunication Union

J

JSON - JavaScript Object Notation is a lightweight data-interchange format that is easy for humans to read and write, and for machines to parse and generate, based on a subset of JavaScript Programming Language.

L

LINKED DATA - in computing, linked data (often capitalized as Linked Data) is a method of publishing structured data so that it can be interlinked and become more useful through semantic queries. It builds upon standard Web technologies, in a way that can be read automatically by computers.

LINKED OPEN DATA (LOD) - linked Open Data defines a vision of globally globally accessible and linked data on the internet based on the RDF standards of the semantic web.

LPIS - Land Parcel Identification System

M

M2M - Machine to machine: direct communication between devices using any communications channel

METADATA - is "data [information] that provides information about other data". Many distinct types of metadata exist, among these descriptive metadata describes a resource for purposes such as discovery and identification. It can include elements such as title, abstract, author, and keywords.

O

ODI - Open Data Institute

OG - Operational Group (in EIP-Agri programme)

OPEN DATA - is data that can be freely used, reused (modified) and redistributed (shared) by anyone (Open Knowledge International).

OWL - Web Ontology Language that is a Semantic Web language designed to represent rich and complex knowledge about things, groups of things, and relations between things.

<https://www.w3.org/OWL/>

P

PA - Precision Agriculture

R

RDF - the Resource Description Format (RDF) is the W3C standard for web data. It allows for data to be linked, anywhere, and to be "grounded" in semantic descriptions of the data. The core RDF data model is very simple: It is a set of triples organized into a RDF Graph. See RDF Concepts.

RDP - Rural Development Programme

RING - Routemap to Information Nodes and Gateways (RING)

S

SEMANTIC WEB - Semantic Web technologies enable people to create data stores on the Web, build vocabularies, and write rules for handling data. Linked data are empowered by technologies such as RDF, SPARQL, OWL, and SKOS.

SKOS - SKOS provides a standard way to represent knowledge organization systems using the Resource Description Framework (RDF).

SMART FARMING - Smart Farming can provide the farmer with added value in the form of better decision making or more efficient exploitation operations and management. Smart Farming applications do not target only large, conventional farming exploitations, but could also be new levers to boost other common or growing trends in agricultural exploitations, such as family farming (small or complex spaces, specific cultures and/or cattle, preservation of high quality or particular varieties,...), organic farming, and enhance a very respected and transparent farming according to European consumer, society and market consciousness. Smart Farming can also provide great benefits in terms of environmental issues, for example, through more efficient use of water, or optimisation of treatments and inputs.

SPARQL - an RDF query language, i.e. a semantic query language for databases, able to retrieve and manipulate data stored in RDF format.

V

VERCON - Virtual Extension and Research Communication Network

X

XML – the Extensible Markup Language

DIGITAL SYSTEMS IN AGRICULTURE 4.0

Module 3

9 DIGITAL SYSTEMS IN AGRICULTURE 4.0

The modernisation of agriculture over the last three decades has progressed exponentially, with developments within the IT sector being one of main drivers of this process.

In an industry that employs well over 40% of the global population, the technologies used in today's agricultural industry is valued at a staggering **\$7.8 trillion**, (AgFunder, 2017). However, according to a McKinsey Report³, the pace of innovation in agriculture is actually much slower than other major industries. The AgFunder Report of 2017 identifies several factors that determine the pace of technological innovation in agriculture:

- a growing global population set to reach nine billion by 2050
- climate change and global warming
- environmental degradation
- changing consumer demands
- limited natural resources
- food waste
- consumer health issues and chronic disease.

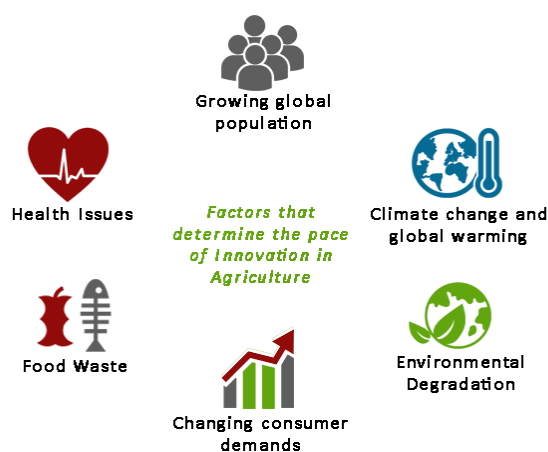

Figure 25: Source: AgFutura

Factors that determine the pace of innovation in Agriculture:

[1] ³ Source: Agritech research

Agro-food innovations today are mainly focused on solving the following challenges:

- food waste
- Co2 emissions
- chemical residues and run-off
- drought
- labour shortages
- health and sugar consumption
- opaque supply chains and distribution inefficiencies
- food safety and traceability
- farm efficiency and profitability
- unsustainable meat production [2].

In 2017 total investments for upstream innovation was **\$4.2 billion** - 24% growth compared to investment in 2016. Within this overall sum, investments in **Farm Management Software, Sensing & Internet of Things (IoT); Farm Robotics, Mechanization & Equipment; Novel Farming Systems Indoor farms** account for 12% of this total (\$504 million).

Categories of Agro-Food technologies:

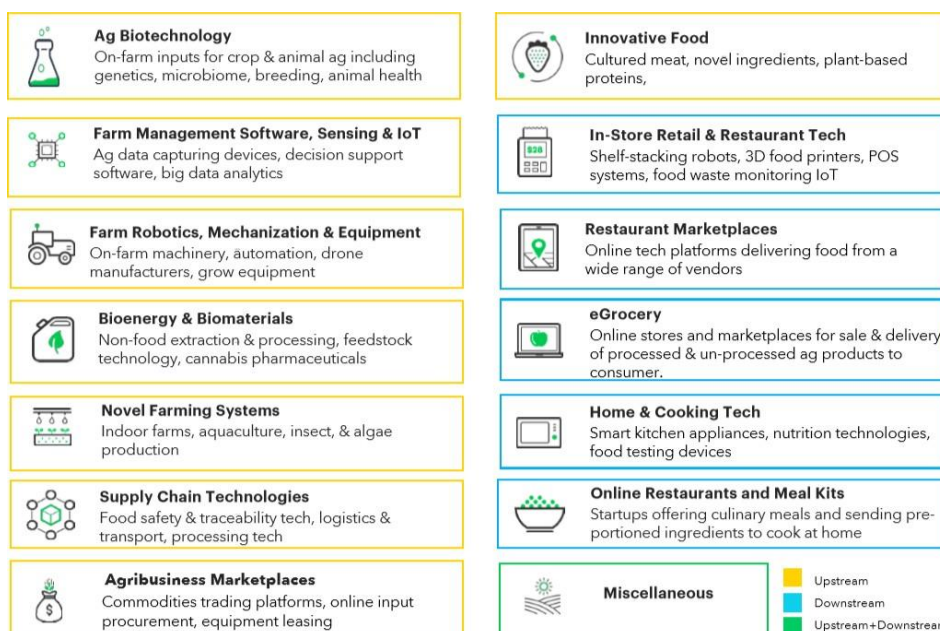

Figure 26: Source: <https://research.agfunder.com/2017/AgFunder-Agrifood-Tech-Investing-Report-2017.pdf>

10 WHAT IS AGRICULTURE 4.0?

The global challenge in finding a way of satisfying the projected demand for food in 2050 has stimulated a wave of new technological advances in the area of agriculture and the food industry.

There is a common agreement among the agricultural society that feeding an extra two billion people by 2050 will require solutions relying heavily on innovative use of **information and communication technologies (ICT)**. A commonly used term for the use of technological advances in the agriculture is '**Agriculture 4.0**' – sometimes considered to be the **fourth agricultural revolution**.

Similar terms often used for this concept of [Agriculture 4.0](#) are '**Smart Agriculture**' and '**Digital Farming**'. According to the [European Machinery Association](#) (CEMA), the term [Agriculture 4.0](#) is analogous to the term 'Industry 4.0', a term used to describe the current trend of automation and data exchange in manufacturing technologies.

[Agriculture 4.0](#) can be described similarly as:

- “the integrated internal and external networking of farming operations”.

The scope of this concept, according to these organizations, includes all digital information that can be generated and utilized from all operators in the farming business model. This will include:

- communications with external partners, such as suppliers and end users
- all data transmissions, processing and analysis⁴.



Figure 27: Connection between different segments in agrifood production (Source: <https://www.world-grain.com/articles/6930-agco-collaborates-to-bring-high-tech-solutions-to-the-industry>)

The European Commission's Digital Transformation Monitor ([EC-DTM](#)) concludes that [Agriculture 4.0](#) represents a process that will have a revolutionary effect on all of agriculture and even the global economy⁵.

[Agriculture 4.0](#) includes a large number of concepts that have become common terms within the IT industry, but which are now being utilized also in the area of agriculture - for example the [IoT](#), [Big](#)

⁴ http://cema-agri.org/sites/default/files/CEMA_Digital%20Farming%20-%20Agriculture%204.0_%2013%2002%202017.pdf

⁵ https://ec.europa.eu/growth/tools-databases/dem/monitor/sites/default/files/DTM_Agriculture%204.0%20IoT%20v1.pdf

Data (BD), and **Artificial Intelligence (AI)** - as well as practices common in IT - cooperation, mobility, open innovation (DTM, 2017).

Definitions

Internet of Things (IoT) - is the network of physical devices, vehicles, home appliances, and other items embedded with electronics, software, sensors, actuators, and connectivity that enables these devices to connect, collect and exchange data.

Big data (BD) - is a term used to refer to [data sets](#) that are too large or complex for traditional [data-processing application software](#) to adequately deal with.

Artificial intelligence (AI) - sometimes-called machine intelligence, is [intelligence](#) demonstrated by [machines](#), in contrast to the natural intelligence displayed by humans and other animals.

All of concepts mentioned above are being adapted within the framework of [Agriculture 4.0](#) to offer some technological advantage, i.e. their purpose is to optimize agricultural production using on reliable data sets generated from 'precision agriculture' tools.

Introducing such digital technologies into the agricultural value chain can also force through modifications to farming business models, for example by additional emphasis on *knowledge gathering, analysis and exchange*⁶. Such 'smart' agriculture, increases the **transparency** along the value chain.

In addition to economic effects, the implications of [Agriculture 4.0](#) can be much further reaching impacting on *social and environmental issues* in the farming industry and in society in general.

10.1 TRENDS IN AGRICULTURE 4.0

General Industry 4.0 trends are transforming the production capabilities of all industries, and agriculture is no exception with trends in Agriculture 4.0. **Connectivity** is the cornerstone of these transformations, with the **IoT**s (Internet of Things) being a key enabling technology and one that is becoming a regular feature of today's agricultural equipment.

The [EC-DTM](#) provides a simple categorisation of the main trends in agricultural digitalisation⁷. Some of the key transformations seen within production methods and tools include the following.

- **Connected tractors** – developments in connectivity and localisation technologies (e.g. **GPS**) have contributed significantly to optimizing the usage of tractors. Driving tractors can be made more efficient through the **optimisation of routes, shortened harvesting and crop treatment**. Many optimizations reduce overall fuel consumption.

Other innovations include various **sensors on tractors**⁸ that enable the implementation of the concepts of **PA. ISO 11783** – a serial control and communications data network (commonly referred to as "**ISO Bus**" or "ISOBUS") for tractors and other large machinery used in agriculture and forestry. It is a communication

⁶https://ec.europa.eu/growth/tools-databases/dem/monitor/sites/default/files/DTM_Agriculture%204.0%20IoT%20v1.pdf

⁷ Reference

⁸ See section 4. "Sensors"

protocol and standard for the agriculture industry, and based on the earlier SAE J1939 protocol (which included CANbus). The ISOBUS standard specifies a serial data network for control and communications on forestry or agricultural tractors. The latest technologies, based on standard protocols in line with ISO 11783, enable managers to handle and interpret the many, accurate data sets acquired (many in real time) during all field operations. Managers not only have enhanced, relevant information for strategic decision making, but also to information that can ease the design and implementation of new concepts specific to their farming needs.



Figure 28: Optimization of tractor routes (Source: http://precisionseedandchemicals.com/precision_fielddview/)

Connected tractors and on a macro level:



Figure 29: Source: <http://www.vantage-ro.com/en/news/5-precision-agriculture-technologies-searched-by-farmers/>

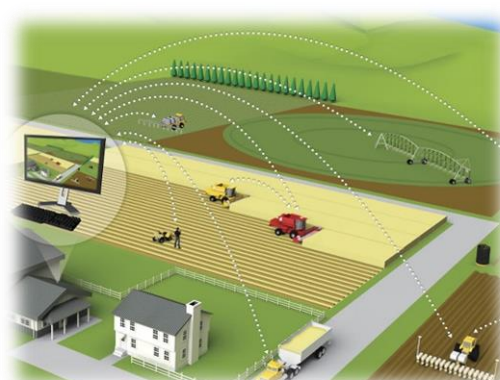

Figure 30: Source: <https://pid.hu/nem-erdekli-tulzottan-az-agrarvallalkozasokat-a-precizios-gazdalkodas>

- **Automation** – a limited, and increasingly expensive, labour force has pushed the agricultural industry to think of ways to increase productivity in all agricultural processes. Innovations in automation are the most effective means of enhancing processes in agriculture.

In the context to automation improvements or adaptations of agricultural machines has been

achieved through 'mechatronic' designs. **Mechatronics engineering** is a multidisciplinary branch of engineering that focuses on the engineering of both electrical and mechanical systems, but can include a combination of robotics, electronics, computer, telecommunications, systems, control, and product engineering. In a mechatronic design process, performances of mechanisms can be improved considerably, or even optimized, through the concurrent and integrated development of precision mechanisms, modern controllers, and advanced information systems.



Figure 31: Tractor Baller Automation (Source: <https://www.youtube.com/watch?v=fpU8MO9Q5c0>)

- **Innovations in measurement tools** – the agricultural industry has developed a raft of new devices that generate data that allows greater precision in, and alternative approaches to, **crop monitoring** and **farm management**.

There are many devices (part of the IoT) that allow the monitoring of entire processes of agricultural production. IoT devices, supported by software systems, can monitor processes from seedling production through crop management (irrigation, plant protection, and plant nutrition) up to post-harvest. These devices and software systems allow primary production to be seamlessly connected and integrated into other phases in the agricultural value chain - such as processing, wholesale, retail and even the final customer (See *Decision support system graphic below*).

In addition to the IoT, progress has also been seen with other tools that provide additional and reliable data that feeds into the **decision support systems (DSS)** used in farm management:

Definition

Decision Support Systems (DSS) are "interactive computer-based systems that help decision makers utilize data and models to solve unstructured problems" (Sprague and Carlson 1982). The goal of such systems is to improve the performance of decision makers while reducing the time and human resources required for analysing complex decisions⁹.

- **Sensors** – these have progressed significantly, both in form and in the places where they can be deployed. Innovation has been particularly rapid in sensors deployed on tractors, in the soil, and in the air.

⁹ https://link.springer.com/chapter/10.1007/978-94-011-2842-1_28

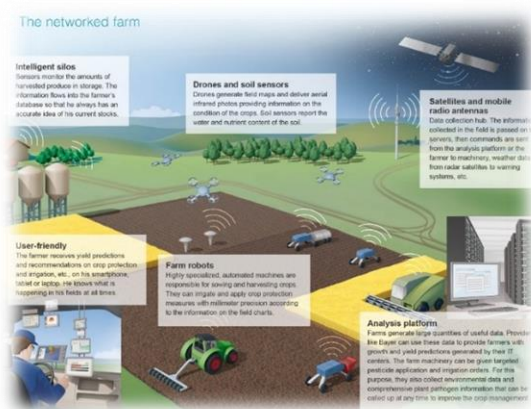

Figure 32: Agriculture Sensors (Source: <https://www.research.bayer.com/en/digital-farming.aspx>)

- **Imagery - UAVs/drones** and unmanned aerial vehicles (basically aircraft piloted by remote control or onboard computers), coupled with readily available satellite imagery, provide high quality data sets and information that can enhance precise support for faster and more effective decision making in areas such as plant vegetation, plant protection, and irrigation.



Figure 33: Drone Imagery (Source: <https://www.research.bayer.com/en/digital-farming.aspx>)

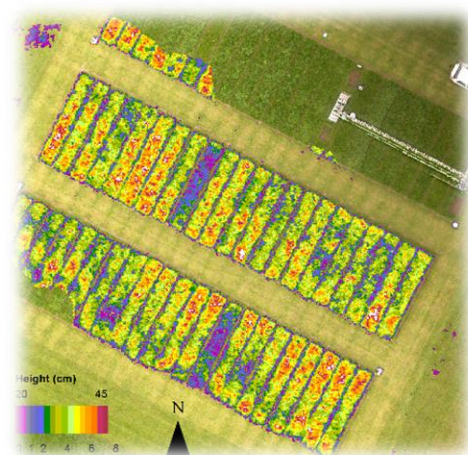

Figure 34: Source: <https://www.zdnet.com/article/data-driven-farming-with-agricultural-drones/>

- **Covering rural areas** – recent developments in **connectivity** have now included coverage of large rural areas, which opens up the deployment of a number of precision agriculture (PA) technologies. Currently available connectivity (including 2G, 3G, 4G digital wireless communications) support the main requirements of commonly available PA solutions.

The challenge at the moment is how to spread this connectivity much wider, to all rural areas¹⁰. There is also the challenge of improving the capacity of connectivity, to enable communications support for more advanced use cases - such as the use of **video**, **full automation** or **augmented reality**. Deploying PA methods in rural areas currently means developing solutions that suit the specific characteristics of the rural environment. This may

¹⁰ <https://www.centerforindustrialdev.com/single-post/2018/03/05/Agriculture-40-Insights-on-the-Next-Revolution>

imply restrictive use where there are factors such as limited access to power, high levels of dust, rainfall, vibration, etc. These factors can significantly delay or restrict the adoption of PA technologies.



Figure 35: Satellite image (Source: <https://www.cursosteledeteccion.com/aplicaciones-de-la-teledeteccion-en-el-ambito-forestal>/<https://www.cursosteledeteccion.com/aplicaciones-de-la-teledeteccion-en-el-ambito-forestal>)

Definition

Connectivity - a generic term for connecting devices to each other in order to transfer data back and forth. It often refers to network connections, which embraces bridges, routers, switches and gateways as well as backbone networks. It may also refer to connecting a home or office to the Internet or connecting a digital camera to a computer or printer

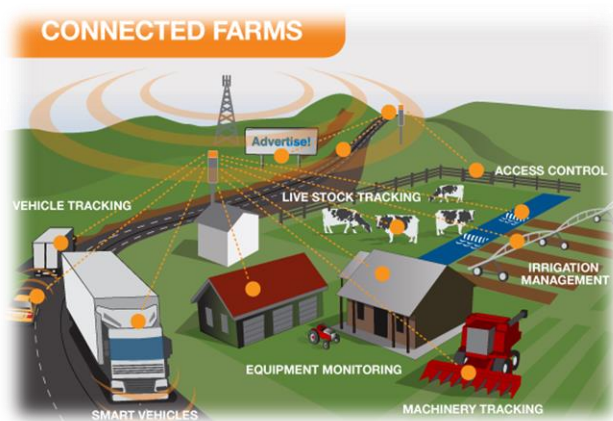

Figure 36: 5G Connectivity and Agriculture 4.0 (Source: <http://www.emfexplained.info/?ID=25916>)

- **Legacy technology** – the development of digital agriculture must progress in line with the development of the environment where the solutions will be deployed. Therefore, innovations and solutions must respect the limitations and capabilities of older machinery, as solutions will involve and/or interact with many **legacy technologies**.

Most of the tractors currently in use in the EU, and indeed globally, date from the pre-digital period, so concepts such as IoT and precision agriculture have to be adapted to this environment. These digital technologies also have to fit with the farmer's habits and with their

mentality. Companies are therefore focusing on developing solution that are easy to understand and use, and in line with the given farming environment. The goal is to provide **'plug and play'** solutions.

Definition

In computing, a legacy system is an older existing method, technology, computer system, or application program, "of, relating to, or being a previous or outdated computer system." Often, referencing to a system as "legacy" means that it paved the way for the standards that would follow it.



Figure 37: Old and the new machinery
(Source: <http://www.tractor-photos.com/picture/number381.asp>)

A more general categorisation of innovative trends in digital agriculture is provided in the report *Agriculture 4.0: The Future of Farming Technology* from the world government summit of February 2018¹¹. There are four key areas where technology is causing disruption in the agricultural industry:

1. the development of radically new technologies
2. the use of new technologies to deliver food produced to consumers
3. increased efficiencies in the food chain, by incorporating cross-industry technologies and applications
4. standardisations of 'plug and play technologies in agricultural machinery.

10.2 CHALLENGES

CEMA - the voice of the Agricultural Machinery Industry in Europe - has identified the following challenges in the development of digital technologies in Agriculture¹².



Trust – Survey results have shown that the main concern among farmers is sharing valuable data with third parties. The issue of data ownership may seem fairly simple and straightforward, but there are many layers to dig through.¹³ Establishing trust presents a serious challenge, especially when considering the fact that agriculture has not been the focus of the IT industry and policy. Farmers have expressed a willingness to share data if there is an obvious benefit for them and if they understand the risks. *Therefore, industry should look at solutions that help to unlock this data by developing rules for, and transparency of, contracts with farmers.*

¹¹<https://www.oliverwyman.com/content/dam/oliver-wyman/v2/publications/2018/February/Oliver-Wyman-Agriculture-4.0.pdf>

¹² http://www.clubofbologna.org/ew/ew_proceedings/2017_S1_3_PPTX_ADAM.pdf

¹³ 'The Dirt on Data Ownership', by Ben Craker (July 2017)



Suitable Infrastructure – [Agriculture 4.0](#) cannot be achieved without the proper infrastructure. The industry needs to solve the challenge of developing and installing proper [ICT](#) infrastructure in all rural areas, as well as providing supporting infrastructure (security, logistics etc.). This is particularly important for more complex precision agriculture solutions based on imagery (filed cameras, satellite etc.)



[Interoperability](#) – there are issues surrounding access to and exchange of data, as well as the overall management of this information over a complex data ecosystem covering the entire agricultural value chain. Worldwide, at this point in time, there are a wide variety of digital solutions covering different segments of the agricultural value chain. Developers and innovators must be aware that these solutions have to be able to communicate with existing solutions on the market, i.e. be compatible with the various legacy systems in use.



Establishing [links](#) with other sectors – Cross sectoral cooperation in developments in [Agriculture 4.0](#) is happening now. Digitalization in agriculture is not just influenced by innovation in [ICT](#), but [ICT](#) does play a significant role as a mediator for connecting edge, or even conventional, technologies and developments in other sectors (such as space technologies, mechanics, medicine, chemistry, environment, etc.) to agricultural process needs.

11 DATA SOURCES

11.1 DATA SOURCES AND DATABASES

Information and communication technologies (ICT) are changing at a rapid pace, and they obviously have an effect on how agriculture is developing. However, as a consequence, information management is becoming an increasingly challenging task for farmers, particularly in terms of the amount of data collected and the complexity of processes at the heart of farming.

Collecting the data from the many **data sources** (e.g. IoT devices, tractors, labour, management, etc.) presents one of the key challenges in digital agriculture. Data sources can differ widely, according to applications or the mechanisms of observation.

Software systems for agriculture can have multiple data sources depending on their purpose or function. Many applications, and most web sites, will rely on data being stored in a **database management system**, and link to these as their primary data sources. Various hardware systems, such as input devices and sensors, may use the environment as the primary data source.

Definitions

In computing a **data source** is the *location of the data* that is being used within a system or application. Typically data is held in a DBMS, where the primary data source is the database, and this can be located locally on a computer disk or remotely on some server (e.g. on the Internet). However, data sources can also be simple files, a data sheet on a spreadsheet, an XML file or even a live data feed from a camera, sensor etc.).

A **database management system** is software system for creating, organising and managing data. The DBMS provides users and programmers with a systematic way to create, retrieve, update and manage data.

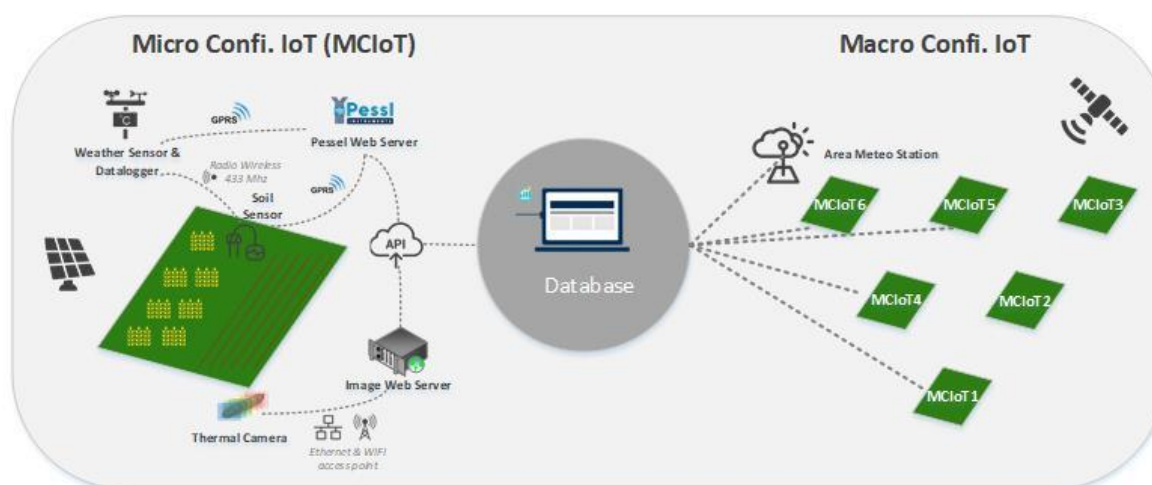

Figure 38: Database management system

Connectivity in Agriculture:

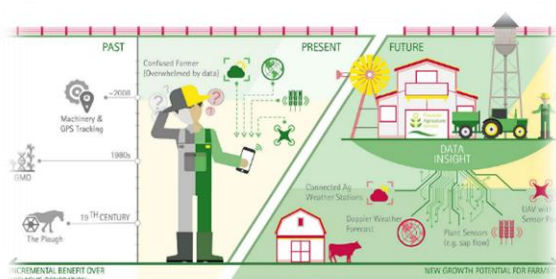

Figure 39: Source:
<https://medium.com/remote-sensing-in-agriculture/digital-technologies-in-agriculture-adoption-value-added-and-overview-d35a1564ff67>

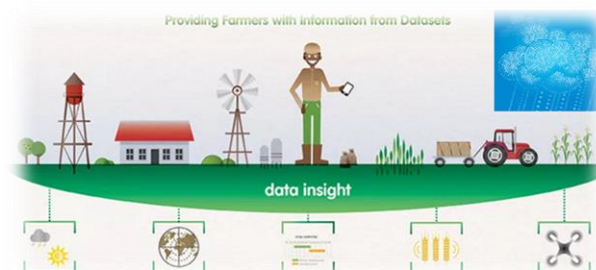

Figure 40: Source:
<http://aims.fao.org/activity/blog/bigness-big-data-building-your-infrastructure-base-agriculture>

11.1.1 THE IMPORTANCE OF DATA FOR THE FARMING BUSINESS

Data and information handling will be one of the key factors for the European farming sector in its drive to become more productive and sustainable, and to remain competitive on the global market.

Within the agricultural value chain as a whole, data is a key component in the production of more, better, and safer food for a growing population, while at the same time reducing the environmental impact. Automated process-data provided by a wide range of ICT devices is at the very heart of the drive towards information-led agricultural production. For example:

- IoT devices include a range of sensors (e.g., for soil, crop, irrigation, etc.) able to collect large amounts of valuable data needed for effective and efficient decision-making and **decision support systems**.
- Digital technologies, such as provided by *satellites* and *drones*, can provide remotely sensed data in real-time relating to in-season crop growth and development, soil moisture, and other dynamic variables (Capolupo et al., 2015).

Advances in the *performance* of computers have paved the way for the processing of very large amounts of data in short time frames. Today's computing power supports that handling of extremely large data sets that can be analysed to reveal patterns, trends, and associations - basically providing an 'explanation' of large quantities of data. These datasets and systems are generally known as 'big data' (NESSI, 2012)¹⁴.

Data can be used to scale and validate plant management models in ways not previously possible, and to make available to large numbers of end users. Today's farming community expects, and relies on, more and higher quality of information to be available in support of daily decision-making in the farming business.¹⁵

There are many benefits for information-based farming, including:

- **Data as a technology enabler.** Precision agriculture tools rely on relevant and accurate farming data. For instance, many **variable rate technologies (VRT)** are reliant on soil sampling. Initially soil samples were quite limited, but the volume and quality of data was significantly improved with yield monitoring applications based on ITC. It is possible now to improve variable rate maps even more, using algorithms based on data from multiple fields and taking into account parameters not directly related to the field itself, e.g. seed characteristics and environmental conditions.

¹⁴ See section "What is [Agriculture 4.0?](#)"

¹⁵ <https://www.sciencedirect.com/science/article/pii/S0168169908002226>
<https://www.sciencedirect.com/science/article/pii/S0308521X16305637>

- **Improved production processes and transparency.** For the end customer, *traceability* within the entire value chain has been greatly enhanced through IoT devices and software systems, working in conjunction with automated collection and the targeted analysis of data. This traceability provides much higher levels of transparency for the end customer. Traceability enables more effective evaluations of current operations within the agricultural value chain, as well as indicating directions for further improvements.
- **Decision support.** Today's ICT solutions in digital farming enable data processing and data analysis to be undertaken at a much higher scale than that possible even a small number of years ago. The quality of, and value from, data analysis as enabled by new technologies in digital farming, and supported by tried and tested algorithms, represents a now invaluable tool in farming decisions support systems.
- **Data exchange / benchmarking.** Networking always opens up new opportunities, and farming is not an exception. Working with external partners, and in particular accepting the benefits of automated integration of information and data, can lead to a considerably broader knowledge base being developed, and hence to decision-making based on well-founded data and cases. Value (and the development of trusted algorithms) is created based on data captured in all areas of the production chain.
- **Optimization of farm operations and resources.** Digital solutions can improve and enhance the optimization of available resources in farm processes. Having access to accurate data that defines the given conditions in a particular field (e.g. soil composition, plants and climate) supports improved decision making and use of resources. Resources can also begin to be optimized to match the needs of the business and to suit specific environmental conditions pertaining to a particular farming site.

11.1.2 DATA STREAMS

The report "*Digital and Data-Driven Agriculture: Harnessing the Power of Data for Smallholders* from the Global Forum on Agricultural Research and Innovation (GFAR)", identified four key data streams for farming data: ¹⁶

- **Data generated and collated on the farm for use only on the farm.** This is called '**localized**' data, and includes: soil data (soil form, soil depth, nutrient composition); seed and fertilizer use; date of sowing; production practices; water use. This is data covering the immediate location, and is generally generated and managed by the farmer or by an agent acting on behalf of the farmer. Normally it would be data that is owned by the farmer.
- **Data generated and collated off the farm, for use on the farm.** This is called '**imported**' data. Imported data is usually owned, managed and controlled by a third party and made available, directly or through intermediaries, for the farmers and their representatives. Farmers do not own this data, unless they have purchased it or they have permission to exploit it.

These data services are generally provided by private or semi-private organisation, explicitly selling data packaged for clusters of customer groups. Common examples are **climatic data**, and data for **market prices** that have been pre-interpreted and customized for on-farm use.

- **Data generated and collated on the farm for use off the farm.** This is called '**exported**' data and it is usually processed, aggregated or combined with other data and information generated elsewhere. It is intended to be used by various actors and stakeholders, such as governments or private companies. Whilst this data may be collected from farmers (using sophisticated tools such as drones or remote sensing), a third party usually owns this data.

¹⁶<https://cgispace.cgiar.org/bitstream/handle/10568/92477/GFAR-GODAN-CTA-white-paper-final.pdf?sequence=3> and 4 See: Chaves Posada, J. 2013. *Achieving Farmers Rights in Practice: GFAR. Discussion Document*. Rome: Global Forum on Agricultural Research. http://www.gfar.net/sites/default/files/cgiar_farmers_rights_report_final_aug_13.pdf; and CGIAR. 2012. *CGIAR Principles on the Management of Intellectual Assets*. Montpellier: CGIAR <http://hdl.handle.net/10947/4486>

There are growing concerns to safeguard this data for the farmers, to ensure it is not exploited to their cost. To this end some data collectors, such as scientists, have adopted ethical guidelines to ensure the data they collect does not then exploit the farmers who provide it. Some governments similarly regulate data collections to counter perceived data piracy (see the *Nagoya Protocol on Access to Genetic Resources and the Fair and Equitable Sharing of Benefits Arising from their Utilization*). These are regulatory guidelines to safeguard the rights of citizens.

- **Data generated and collated on/off the farm, mainly for use off the farm.** This is called 'ancillary' data. A large proportion of agricultural data, such as government statistical and research data, are generated using various data sources in other value chains. While this data may initially appear to have little direct on-farm application, various policies and policy changes may lead to indirect on-farm influences that were not previously foreseen.

This type of data typically has many owners, platforms, and associated products. Some subsets of these data sets may find their way to farmers, either directly through 'importing' services or indirectly via other actions and changes that may have had an influence to what happens on farms.

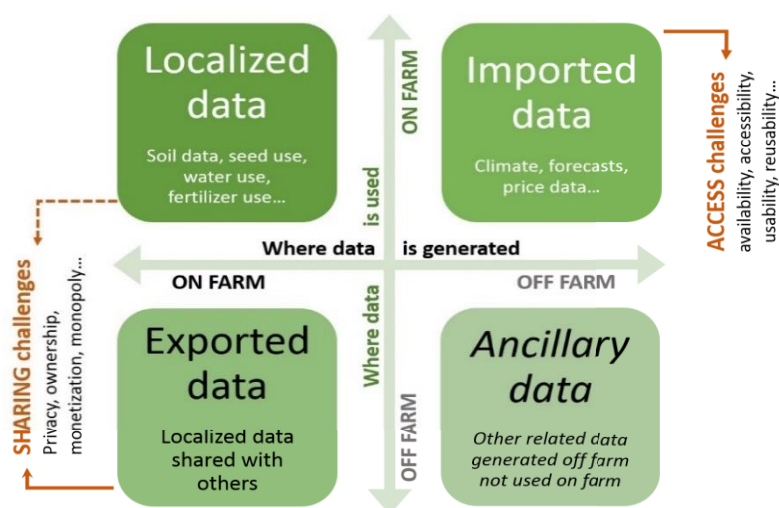

Figure 41: Figure 43: Data streams in farming (Source: <https://goo.gl/oJQ6ms>)

11.2 SAMPLING

Digital agriculture is based on reliable data providing information about the state of the agricultural item (soil, crop, livestock etc.) that is subject of observation.

Understanding the different aspects of agricultural production, and for making precise farming decisions, requires performing analyses for the population of certain item.

Definitions

Sampling is the process of choosing a representative sample from a potentially large target 'population' and collecting data from that sample in order to understand something about the population as a whole.

A population can be defined as all items and characteristics being studied. Gathering all information about every item would be time consuming, costly and probably impossible. By sampling a subset of a population, inferences can be made about the population as a whole.

In sampling, it is assumed that small samples drawn from a large population have means (averages) that are equal.

When precision agriculture is implemented in real world conditions it much data to be acquired, specifically *spatial* and *temporal data* for a number of key aspects of agricultural production, e.g. measurements of soils, crops and livestock, etc. An analysis of this data then helps agricultural experts and farmers to understand the variability of each key item in the farming process, which can (and should) lead to more efficient and effective decision making in the use of farming technology and in the farming business processes. Some of the statistical techniques used for estimation and forecasting in agriculture include:

- censuses and surveys in specialized areas of interest
- remote sensing and GIS technology
- agro-metrological techniques

Remote sensing and GIS technology are advance technologies used to estimate crop area, yield and land use statistics. Agro metrology is the science of studying the influence of metrological conditions on the growth and development of fields, fruit and other crops, and aimed at determining the needs required to reach the optimal biological productivity.

11.2.1 TYPES OF SAMPLING

In this section you will learn about:

- nutritional levels in the soil over separate and distinct areas (zones) within a field subject to cultivation.
- various methodologies of obtaining crop samples to create data that represent the health status of specific crops
- usages and purposes of livestock samples.

11.2.2 SOIL SAMPLING

Historically, the objectives of soil sampling were to determine the average nutrient status of a field and to provide some measure of nutrient variability in a field.

Definition

The definition of 'soil' in soil science is "**an independent body in nature with a unique morphology from the surface down to the parent material as expressed by the soil profile**"¹⁷.

Soil is the product of biochemical weathering of the parent material, and its formation is influenced by the soil formation factors: *climate, organisms, parent material, relief, and time* (Jenny, 1941; Brady, 1990).

The main objective of soil sampling in the context of precision agriculture is to understand the nutritional levels in the soil over separate and distinct areas (zones)¹⁸ within a field subject to cultivation, and hence observation.

By performing analyses on soil samples, agricultural experts and farmers can begin to understand the relationship between **soil fertility levels** and other properties of the field that can be predicted and measured. Factors that influence soil nutrient levels, and hence the determination of the soil sampling approach to be employed, include:

- soil type
- topography
- cropping history
- manure applications
- land levelling for irrigation
- fertilizer management practices.

The process of statistical sampling, in the context of soil analysis, provides information about the population (in this case, a group of soil samples which significantly represents the field area that is that subject of analysis) characteristics on the basis of **representative sample observations**.

¹⁷ Tan, K. (2005). Soil Sampling, Preparation, and Analysis. Boca Raton: CRC Press.

¹⁸ See zoning

Obtaining a truly representative soil sample can be a very challenging job.

Sampling errors are more frequent than analytical errors (Reed and Rigney, 1947), so the importance of accurate sample cannot be overstated. The extent to which the result of an analysis actually identifies a real characteristic of the soil population depends critically upon on the accuracy of sampling.

If the sample analysed is not truly representative, then the result of the soil's chemical analysis will likely generate values per soil parameter that do not accurately describe the property of the zone, and hence the field, that is the subject of the analysis. This situation can lead to the development of unsuitable plant nutrition programmes, higher costs or – in the worst cases - **soil degradation**.

Samples must be collected at the proper depths to ensure accurate measurements of mobile and non-mobile nutrients. Samples should also be handled and stored in a manner that minimizes contamination and degradation (See figure below).



Figure 42: Example of soil probe sampler

The population characteristics is defined based on the values of different micro and macro elements in the soil (See picture below).

Micro and macro elements in the soil (left), Automatic soil sampling (right):

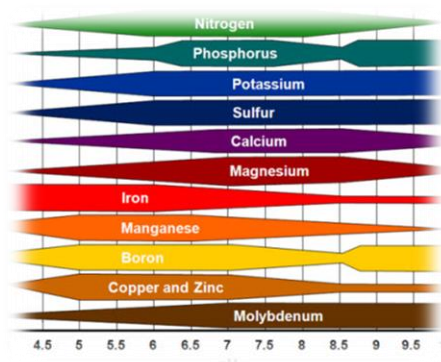

Figure 43: Source: SOMOCO Project

Definition

Plant nutrition analysis is performed to study the chemical elements (nitrogen, phosphorous, etc.) and compounds necessary for plant growth, plant metabolism and their external supply of these element¹⁹.

¹⁹ https://en.wikipedia.org/wiki/Plant_nutrition

Soil analysis provides an insight into the nutrient reserves in the soil, and can be used as a guide for precise crop management – including plant nutrition, irrigation etc.

Soil sampling has been regularly employed practice in agricultural system in western countries for quite some time. Soil analysis - for the purpose of implementing precision agricultural practices – is, however, more common in corporate farming in small family farms²⁰.

In the last decade, though, farming businesses in Eastern Europe are showing increased awareness of the use of soil data for improved crop management. This is probably a result of increased competition in the global farming business, of labour shortages and of increased prices of agricultural inputs.

All these factors put pressures on farmers to be more accurate with their decision-making.



Figure 44: Different types of soils (Source: SOMOCO project)

11.3 SOIL SAMPLING METHODOLOGIES, TECHNIQUES AND DIGITAL TOOLS

11.3.1 GRID SAMPLING

The development of site-specific nutritional programmes for plants based on **global positioning systems (GPS)**, as used for the purpose of implementation of **variable rate fertilization (VRF)**, demands that soil sampling is organized into a systematic **grid patterns**, i.e. a network of intersecting parallel lines (see figure below).

Grid Sampling (left), Management zone sampling (right):

²⁰ Visegrad 1 project reference

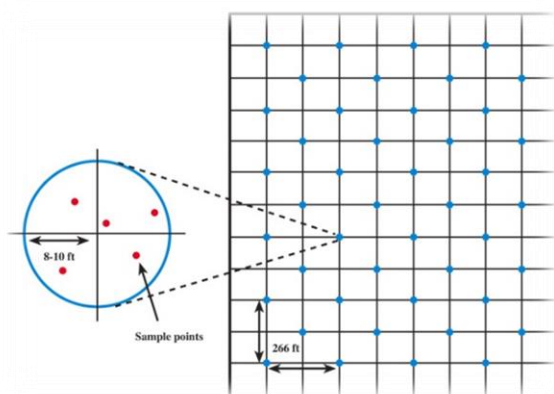

Figure 45: Source: https://www.researchgate.net/figure/Farmer-defined-management-zones-and-sampling-locations-of-field-L_fig2_226626719

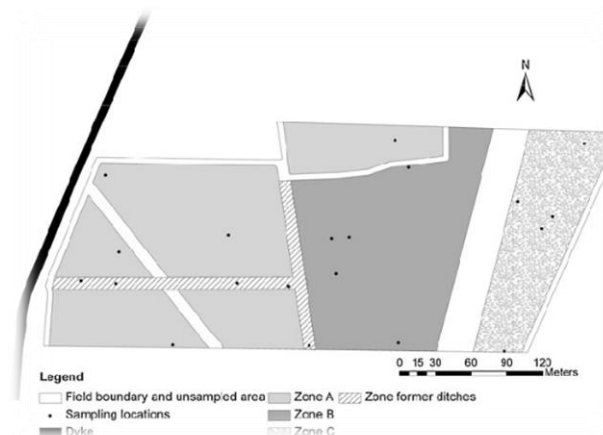

Figure 46: Source: <https://cropwatch.unl.edu/ssm/soilsampling>

A plant nutritional map, based on grid sample, is a valuable resource for precision plant nutrition though it should ensure that the density of the samples is adequate enough to provide confidence in the accuracy of the maps developed from the data. Any variable rate technology (VRT) applications of fertilizer can the potentially change the patterns of nutrient levels or soil pH over time. Some parameters, such as soil phosphorus levels, will not however change drastically with single Variable Rate Technology applications.

11.3.2 MANAGEMENT ZONE SAMPLING

Soil sampling information from management zones is created built up from several sources of data.

The first layer of data should be that from soil samples collected in the past. Additional layers of data from more precisely defined zones provided by yield maps, aerial photographs and remotely-sensed images. These additional sources provide information showing where soil sampling can help to interpret variability even more precisely.

Determining patterns that show consistency from one data layer to another (for example, consistent yield maps with data provided by aerial photo) gives a clearer picture of the situation in the field, and hence where sampling is most needed. Experience gained from tillage, cultivation, harvest and scouting the field presents another information layer that can be used for management zone sampling.

The key factors that influence sample patterns are soil compaction, topsoil depth, slope, landscape position and texture.

RECOMMENDATIONS

Grid sampling is recommended if previously performed crop management has significantly changed the nutrient levels of the soil as a results of confined livestock, heavy manure application, significant levelling for irrigation or other extreme agricultural practices.

Additionally, grid sampling can be performed in cases of small fields with a diverse cropping history.

Management zone sampling is preferred if additional digital data - yield maps, remotely sensed images, or other sources of spatial information - are available for analysis.

These data provide knowledge of the different layers of the agricultural field, which gives additional dimension for creating a strategy for management zone sampling. This methodology is also recommended in cases where there is limited, or no, history of livestock or manure influence on the field.



Figure 47: Traditional soil sampling (Source: <https://www.indianaprairiefarmer.com/management/crops-consultant-prefers-soil-testing-management-zones>)

11.3.3 3D MAPPING

Three-dimensional quantitative modelling is relatively new in soil science.

Quantitative mapping has improved the potential for modelling soil complexity in 3D using advanced algorithms and geostatistical techniques. **3D mapping**, as a source of data for precision agriculture, is used to understand the actual physical conditions in the field and the terrain (evaluation, slopes, etc.). This type of data combined with **geostatistical data** can then be used for mapping water flows, to monitor erosion and soil loss.

This combined data can help agricultural experts and farmers to understand the history of the soil in the field of observation, and hence the potential for the cultivation of future crops.

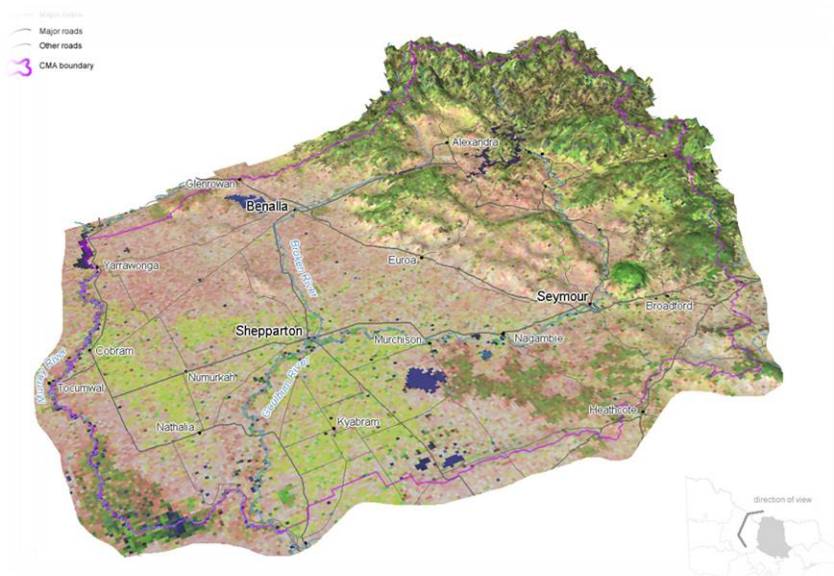
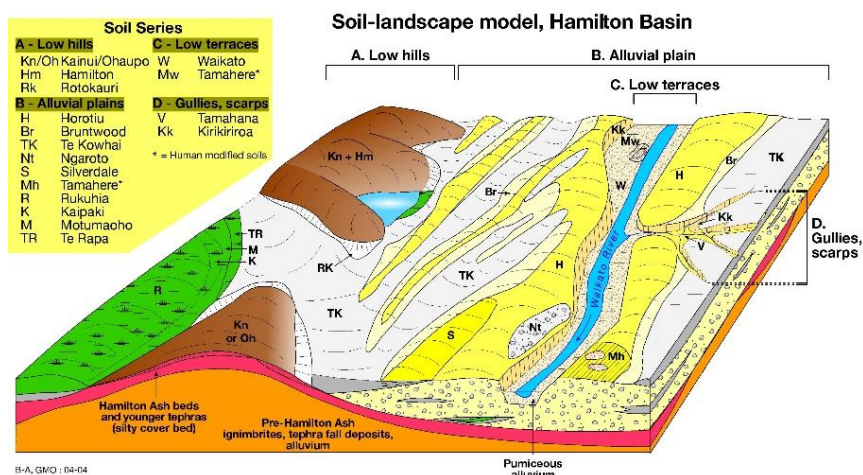

Figure 48: 3D mapping (Source: <http://pubs.sciepub.com/ajcr/2/4/2/figure/10>)

11.3.4 SOIL MODELLING



The range of soil-modelling activities provide a set of tools that can be used to quantify and predict soil **supporting** and **degradation processes**, as well as **regulating** and **provisioning services**.

Figure 49: Soil Modelling
(Source: <https://sci.waikato.ac.nz/farm/content/soils.html>)

Definition

Soil modelling is the quantitative description of the **physical, chemical, and biological** interactions in soil at multiple scales and levels of refinement.

Soils underpin the very existence of us all through food production, and they are also the largest terrestrial carbon store. Understanding the state of, and changes in, the soil in response to climate and land use is of key importance and hence a major challenge.

It is vital, therefore, to preserve the natural capital is soil, and to arrive at a mass balance between soil degradation, erosion and production. These various factors that have to be considered include the following.

- **Soil supporting processes.** These refer to basic soil processes that enable soils to function, and which ensure the formation and maintenance of its natural capital. These processes include *soil formation and soil structure, nutrient cycling and primary production, and soil biological activities*.
- **Soil degrading.** Many processes can diminish the natural capital of soils through various mechanisms, including *erosion, surface sealing, compaction, salinization, loss of nutrients, acidification, and loss of organic matter and biodiversity*.
- **Regulating services.** These are necessary to provide means whereby humans can live in a stable, healthy and resilient environment (Dominati et al., 2010). They include *climate regulation, water regulation, erosion control, buffering, and filtering*.
- **Climate regulation.** This is defined as the capacity of the soil to control states and fluxes of energy, water and matter that might impact climate.
- **Water regulation.** This comprises soil services related to the storage and retention of quantities of water. It can affect soil hydrological processes (such as runoff, leaching, and groundwater recharge) and water management practices (such as irrigation and drainage). Soils have the capacity to store and release chemicals, thereby effecting some control over soil, water, crop, and air quality.
- **Provisioning services.** These are related to products derived from ecosystems (e.g., food, wood, fibre, fresh water, physical support, and genetic resources), in all of which soils play a key role. Underlying these processes are basic biological, physical, and geochemical processes. Most soil modelling research thus far has been focused on addressing these basic processes independently or coupled with a limited set of basic processes.²¹

²¹ Modeling Soil Processes: Review, Key Challenges, and New Perspectives H. Vereecken,*



Figure 50: PA soil zoning (Source: <http://www.ipf-uk.com/precision-farming/soil-zoning/soil-zoning.html>)

11.3.5 SOIL ZONING

Definition

Soil types, textures and make-up can vary across fields, causing crop variations and performance.

Soil zoning, in the context of agriculture, is the formation of zones within a field based on the characteristics of the soil determined from soil analysis and other methods. By dividing the field into separate soil management zones, soil variations can be managed through variable rate applications.

With zoning, farmers can create economical units/zones based on soil characteristics, and possibly other components of the landscapes depending on where an agricultural field may be positioned.

In performing zoning for agricultural purposes, it is important to consider many factors including the regional features of the soil cover. Regional features of the soil can be acquired from satellite images or, in the case of smaller areas, from drones and **UAVs**.

Knowledge of the interrelations of soils with the natural conditions on a field site is essential to plan and perform farming activities that avoid damaging the structure and fertility of the soil.

In addition to planning possible chemical processes (plant nutrition, plant protection, irrigation) in agricultural production, soil zoning is used also for 'agroforest' and erosion control measures, in the development of forest resources, and for environmental protection.

11.3.6 CROP SAMPLING

Primarily, samples from the plants are used to obtain and provide information on the nutrient status of the plants, as a guide to nutrient management for optimal plant production.

For example, samples analysed can provide information about possible over-fertilization of crops and pastures. Sampling can also be used for potentially many other reasons:

- the assessment of the quality of plant products
- estimations of nutritional status of regions, districts and soil types
- the nutrient levels in diets available to livestock and for human nutrition
- as an indicator of environmental toxicities.²²

²² D Reuter, JB Robinson (1997) Plant Analysis: An Interpretation Manual

Definition

A partial segment of the plant habitus, or the whole plant that is going to be analysed in the laboratory, is called a crop sample.

In contrast to soils, plant sampling techniques vary considerably from crop to crop and will also depend on crop condition and stage of growth. Depending on the analysis to be performed, leaves, roots or other plant parts can be the component to be sampled.

Crop sampling can assist farmers in the production of accurate, early estimations of grain yield, which is a vital task and an important skill within their businesses. Farmers require accurate yield estimates for a number of reasons:

- crop insurance needs
- delivery estimates
- planning harvest and storage requirements
- cash flow budgeting

GOOD PRACTICE

Representative samples of crops must be taken by following certain well-defined procedures.

- Each plant or fruit should have an equal chance of being part of the representative sample.
- Each sample should be taken with consideration that there will be variability between different samples.

It is recommended the samples be taken from parts of the crop that will consist of the final agricultural product. In crop sampling it is recommended to avoid sampling from diseased or under-sized crop parts, or crop produce at a stage where it would not normally be harvested.

Samples should be taken in a way that properly represents the harvesting practice. Removing surface residues during handling, packing or preparation should be avoided.²³

11.3.7 LIVESTOCK SAMPLING

The main purposes of taking samples from livestock are:

- to identify early diagnosis of pathological activity at the individual animal level
- tracking the activities of an individual animal
- collecting data for decision support systems at the farm level right up to institutional level.

The design, implementation, monitoring and evaluation of livestock for public and private sector investments is generally based on evidence and information generated by a multitude of data collection systems, including regular and one-off, or ad-hoc, surveys.

Understanding these data sources is critical for decision makers in order to make appropriate use of available data and indicators, and it forms the first step in designing and setting up a comprehensive livestock data collection system.

²³<http://agriculture.vic.gov.au/agriculture/farm-management/chemical-use/agricultural-chemical-use/chemical-residues/managing-chemical-residues-in-crops-and-produce/guidelines-for-sampling-soils-fruits-vegetables-and-grains-for-chemical-residue-testings>



Figure 51: Livestock sampling (Source:<https://www.independent.ie/business/farming/programmes-crucial-to-keeping-farms-disease-free-30037379.html>)

11.3.8 PRODUCTION SAMPLING

It is necessary to provide representative samples to a laboratory for analysis in order to determine whether an agricultural product complies with regulations such as:

- Maximum Residue Limits (MRLs) for chemical residues
- Maximum Levels (MLs) for metal residues
- determining whether soils contain organochlorine insecticide residues such as dieldrin or DDT which are a concern to many agricultural interests.

There are a set of general rules for sampling fruit, vegetables and grains. The following procedures are based on sampling methods as recommended by the **Codex Alimentarius Commission** and the **Food and Agriculture Organization**. Sampling should be performed separately in the following situations:

- with different fruits, vegetables or grains
- with different cultivars or varieties
- in areas of crop which have had different chemical treatments, or which have been sprayed on different days
- with produce sourced from different growers for repacking or processing.

As a general rule all samples, particularly samples of perishable fresh produce, should be kept cool but not frozen. However, samples of already frozen foods should be kept frozen until they reach the laboratory. Individual fruits and vegetables should not be cut or divided.

Each laboratory sample should consist of several individual sub-samples. Sub-samples should be taken randomly throughout the lot and should be of a similar size. For example, sub-samples could consist of: a single fruit or vegetable for larger items; a single bunch or bundle for grapes, asparagus, etc; a single punnet or a small scoop of produce for small items (peas, berries etc). If a product has been packaged, sub-samples should be taken from more than one box in the lot.

For cereals and other materials shipped in bulk, a number of sub-samples (at least 10) should be taken from different places. This can be performed by taking small grab samples while it is being unloaded into warehouses or, when grain is stored in bulk, a grain-sampling probe can be used for sampling at different depths.

11.4 SENSORS

In this section you will learn about:

- descriptions and applications of soil sensors, and methods for gathering and transferring data
- techniques for monitoring the health status of plants
- existing sensors that support irrigation decision-making processes
- different types of sensors for phytopathological activities the monitoring of ruminants
- diverse methodologies and sensors that measures grain mass flows for yield mapping
- the uses of UAVs in agricultural production.
- the advantages of environmental sensors
- challenges in adapting to different field situations and sensor interoperability.

A crucial aspect supporting the concept of precision agriculture is how farming data is collected.

One of the main tools for data collection on farm sites are the many different type of **sensors** employed to collect data from different stages of the agricultural production. In this module, material sensors are categorized into four groups covering specific processes in agricultural production.

Definition

A **sensor** is a device that detects and responds to some type of input from the physical environment. The output is generally a signal that is converted to human-readable display at the sensor location or transmitted electronically over a network for reading or further processing.

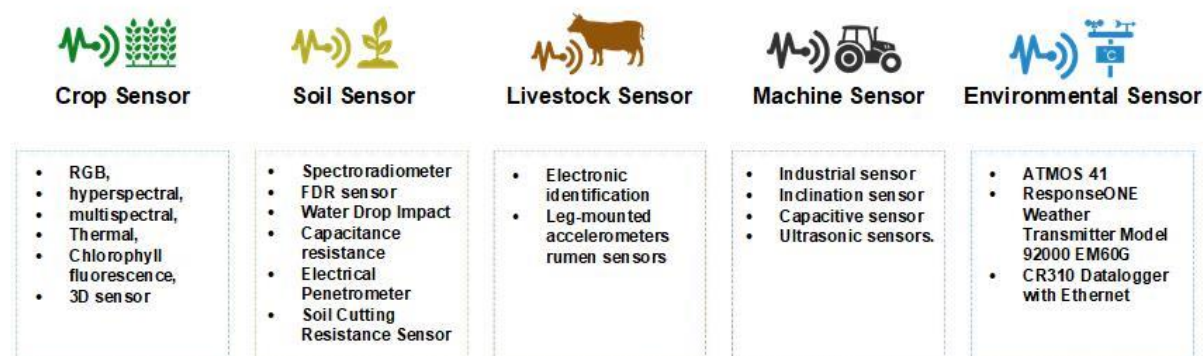

Figure 52: Examples of sensors grouped based on the site of deployment

11.4.1 SOIL SENSORS

Soil is the essential element in farming processes and it obviously plays a fundamental role in crop development and crop yield. It dramatically affects the overall quality of most products through both its intrinsic properties and the effects of external factors.

Spectroradiometer

The **Spectroradiometer** is a **hyperspectral sensor** (i.e. it collects and processes information from across the electromagnetic spectrum) that allows soil attributes to be identified and measured. It can reveal patterns in a soil spectrum that are known to respond to *mineral composition, organic matter, soil*



Figure 53: Source:
<http://www.goepe.com/tp/12360125.html>

moisture and particle size distribution. Spectral analysis is a rapid and inexpensive method of assessing the nitrogen, carbon, carbonate and organic matter composition in upper soil layers.

Frequency-domain reflectometry (FDR) sensor

FDR sensors are used for measuring the soil water status, and are particularly useful in areas of high soil salinity and for assessments of sandy mineral soils in different soil moisture levels. FDR sensors measure the soil's **dielectric permittivity spectrum** – a measure of the soil's electrical capacitance – and its **salinity index** showing the soil water electrical conductivity value.



Figure 54: <http://ictinternational.com/products/5te/decagon-5te-vwc-temp-ec/>

Capacitance and resistivity sensor

Capacitance and resistivity sensors can be used to continuously monitor **soil volumetric water content** and pore-water electrical conductivity. These sensors are part of the set of sensors that provide data for decisions in irrigation and plant nutrition.

Electrical penetrometer



Figure 55: <http://www.environmentalbiophysics.org/tdr-versus-capacitance-or-fdr/>

The electrical penetrometer is designed to determine the **soil cone index** which is a mechanical property used to assess soil strength – which is linked to soil compaction, one of the primary causes of soil

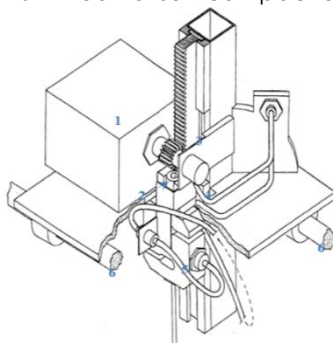

Figure 56:

<https://www.ncbi.nlm.nih.gov/pmc/articles/PMC3545577/>

degradation. Compaction of cultivated soil has significant economic and ecological impacts, affecting *root growth, seed emergence and plant establishment*.

Soil Cutting Resistance Sensor measures the soil-cutting resistance at various depths while traversing the field. The data from this sensor provides valuable information on soil properties that can be used to optimize resources and improve agricultural economy.



Figure 57: Source: Agüera, J.; Carballido, J.; Gil, J.; Gliever, C.J.; Perez-Ruiz, M. Design of a Soil Cutting Resistance Sensor for Application in Site-Specific Tillage. *Sensors* 2013, 13, 5945–5957.

11.4.2 CROP MANAGEMENT: SENSORS FOR MONITORING PLANT HEALTH

The reduction of both qualitative and quantitative losses in plant cultivation for increased crop yield depends on early and accurate detection and diagnosis of **phytopathological** activity in the plant, i.e. the monitoring and detection of disease in plants.

Optical techniques such as *RGB imaging, multi- and hyperspectral sensors, thermography, or chlorophyll fluorescence sensors* have proven their potential in automated, objective, and reproducible detection systems for the identification and quantification of plant diseases at early stages.

Recently, *3D scanning* has been included as an optical analysis that supplies additional information on crop plant vitality. Different platforms from - proximal to remote sensing²⁴ - are available for multiscale monitoring of single crop organs or entire fields. Accurate and reliable detection of diseases is enabled

²⁴ Remote sensing is about mapping the Earth's surface from satellite or airborne systems, while proximal sensing systems collect detailed information near the surface.

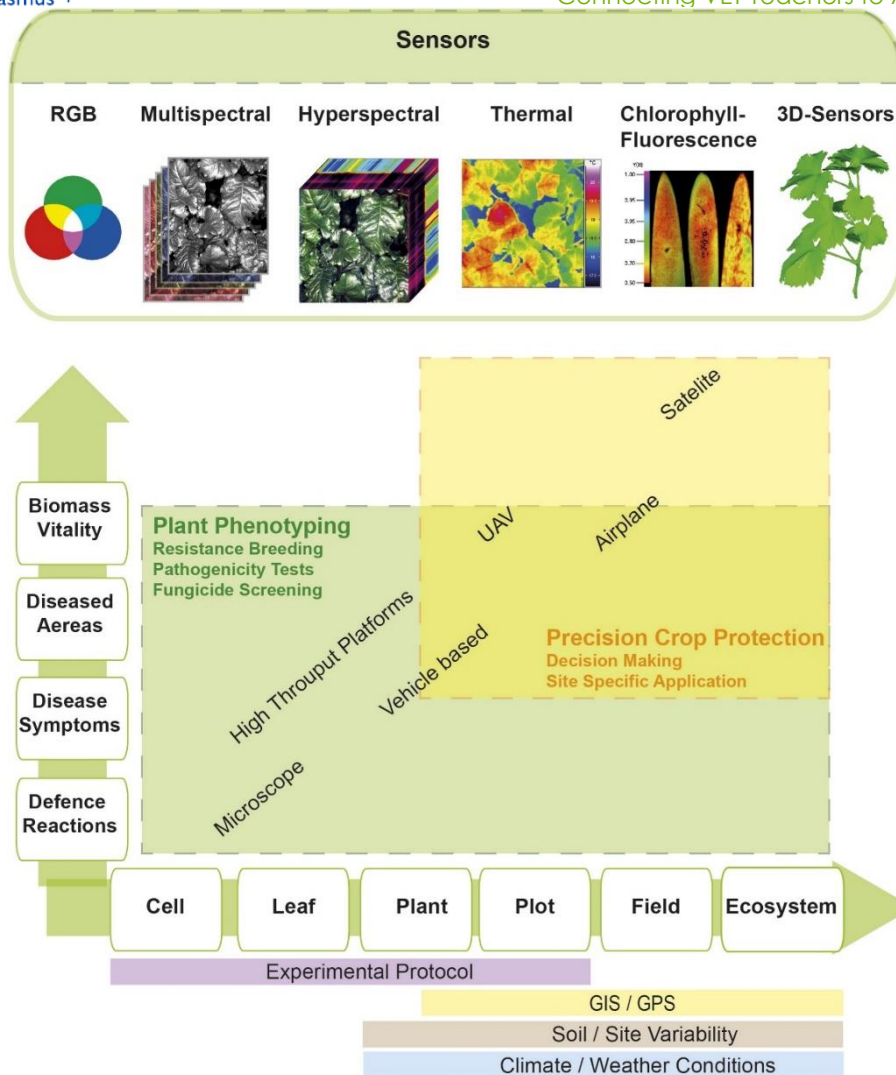

Figure 58: Figure 60: Types of imaging sensors (Source: <https://apsjournals.apsnet.org/doi/abs/10.1094/PDIS-03-15-0340-FE>)

through highly sophisticated and innovative methods of data analysis derived from sensor data that has been obtained from plant-pathogen systems.

In general, sensor-based analyses are highly applicable in the area of precision agriculture and plant **'phenotyping'** - the observable physical or biochemical characteristics of a plant, including both its genetic makeup and its environmental influences.

11.4.3 IRRIGATION SENSORS

There are many ways in which water gets transferred from the land to the atmosphere, e.g. by evaporation from the soil and other surfaces, or by 'transpiration' from plants.

Definition

Evapotranspiration (ET) is the combination of evaporation from the soil surface and transpiration by plant materials.

One of the more challenging tasks of crop management is determining how to control evapotranspiration, i.e. how to replace water lost.

Evapotranspiration can result in significant water loss. It is affected by the type of vegetation being grown and by and land. Water transpired through leaves comes from the roots, and plants with deep reaching

roots can transpire water at higher rates. The key factors that affect evapotranspiration include the plant's growth stage or level of maturity, percentage of soil cover, solar radiation, humidity, temperature, and wind.

If potential evapotranspiration of an area is greater than the actual precipitation, then the soil will dry out, unless irrigation is used. In areas that are not irrigated, actual evapotranspiration is usually no greater than precipitation, though there is some dependency on the soil's ability to hold water – water is generally lost to factors such as how fast or slowly water runs through the soil, or to surface runoff.

There are exceptions, such as in areas with high water tables, where capillary action can cause water from the groundwater to rise through the soil to the surface.

The Evapotranspiration (ET) Method is a commonly used method of determining how much water to apply through irrigation, based on estimates of the amount of water lost from the soil. Evapotranspiration is basically the sum of water loss from evaporation from the soil surface and a plant's loss of water through transpiration.

Irrigation controllers are sensors separated into two main categories.

1. **Climate based controllers.** There are three main types:
 - a. **signal-based controllers** use meteorological data from publicly available sources, calculating the ET value for a grass surface at the site. The ET data is then sent to the controller by a wireless connection.
 - b. **historic ET controllers** use a pre-programmed water use curve, based on historic water use in different regions. The curve can be adjusted for temperature and solar radiation.
 - c. **on-site weather measurement controllers** use weather data collected on-site to calculate continuous ET and water measurements.
2. **Soil moisture based controllers.** Rather than using weather data, soil moisture sensors are placed below ground at the root zones of plant in order to determine their water need. Soil moisture sensors give estimates of the soil volumetric water content.

Definition

Volumetric water content represents the portion of the total volume of soil occupied by water.

Irrigation controllers can be adjusted to open the valves and initiate irrigation if the volumetric water content reaches a predetermined value. The appropriate moisture values depends on soil and vegetation type. Soil moisture sensors must be installed in representative areas across the fields to be of use.

11.4.4 OTHER SENSOR TYPES

Choosing the correct technology for specific situations is essential in order to achieve potential water savings and to deliver an optimal quantity of water for plant needs.

Automatic irrigation system should ideally include a range of sensor types - **soil moisture, rain, wind and freeze sensors** – to optimize the plant's growing environment.

WIND SENSORS

Irrigation distribution uniformity is a key feature for successful irrigation operation.

Strong winds can reduce this uniformity and decrease the amount of water provided for plants for particular soil profiles. In order to manage the water supply, if wind speed exceeds a specific threshold the irrigation cycle can be stopped by wind sensors to avoid waste.



Figure 59: Wind sensor (Source: <http://pods.dasnr.okstate.edu/docushare/dsweb/Get/Document-9443/HLA-6445web.pdf>)

RAIN AND FREEZE SENSORS

There are periods when irrigation is unnecessary, for example during periods of rainfall or periods of freeze. These sensors stop the irrigation cycle during these conditions.

These sensors can avoid waste and water usage in situation of rain and unnecessary runoff, as happens during freezes. There are three main types of rain sensors, each designed for specific conditions.

1. The first type of rain sensor consists of a small cup, or basin, that simply collects water. Sensors measure the weight of the water collected during rainy weather and stops the irrigation cycle if specified conditions are triggered.

Debris can alter the amount of the water collected, so periodic checking is crucial for smooth operation of the sensors.

2. The second type of rain sensor uses a dish with two electrodes positioned at a specific distance from the bottom of the cup. When the water reaches the electrodes, the irrigation cycle is interrupted.



Figure 60: Source:
<http://pods.dasnr.okstate.edu/docushare/dsweb/Get/Document-9443/HLA-6445web.pdf>

3. A third type of rain sensor works on the principle of expanding disks. Once the disks are wet, they interrupt the irrigation cycle. Once the disks dries out, the system will resume the scheduled irrigation cycle.

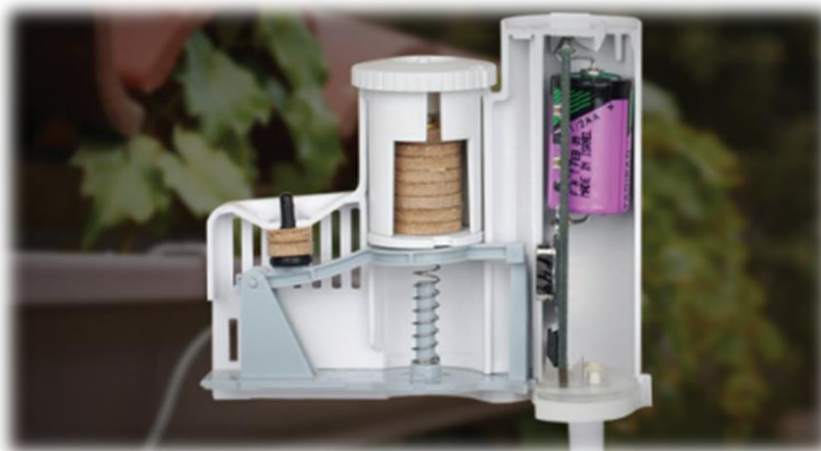

Figure 61: Rain sensor attached to a gutter (top) and the inside of an expanding disc rain sensor (bottom). (Source: <http://pods.dasnr.okstate.edu/docushare/dsweb/Get/Document-9443/HLA-6445web.pdf>)

All of the devices should be installed in open areas where they will receive rainfall without disruption.²⁵

11.4.5 PLANT NUTRITION SENSORS

A wide range of ground-based sensors, working either passively or actively, have been used to produce **vegetation indices (VIs)** for monitoring vegetation photosynthetic activities and biophysical properties.

- **Passive sensor systems** use sunlight as the source of light.

Passive sensors are mostly multispectral or hyperspectral – collecting and processing information from across the electromagnetic spectrum - enabling the calculation of numerous vegetation indices. This makes them more flexible and applicable.

- **Active sensors** are equipped with light-emitting components providing radiation in specific wavelength regions.

Active sensors are limited by their use of several central wavelengths and can thus be used to calculate only a few specific vegetation indices. However they do have the advantage that they can be used independent of solar radiation in the field, i.e. they are active even at night.

²⁵ <http://pods.dasnr.okstate.edu/docushare/dsweb/Get/Document-9443/HLA-6445web.pdf>



Figure 62: ASD Field Spec Pro spectrometer Source: <https://analytik.co.uk/product/portable-remote-sensing-spectroradiometry-fieldspec/>

11.4.5.1 SPECIFIC PLANT NUTRITION SENSORS

There are a number of sensors used to measure and monitor plant nutrition.

- **Chlorophyll measurement sensors** employ a non-invasive method for imaging **photosynthetic photon fluxes** needed to measure the fluorescence that is correlated with the photosynthetic activity.

Definition

Photosynthetic photon flux is a measurement that determines the total amount of **photosynthetically active radiation** a light gives off.

Photosynthetically active radiation defines the type of light needed to support photosynthesis. To achieve successful photosynthesis plants primarily use wavelengths between 400 and 700 nano-meters. The light within this range is called **photosynthetic active radiation**. The **Photosynthetic photon flux** represents the measurement of all the photons in this range.

Measurements of fluorescence helps in the detection of plant stress factors, from the purpose of correcting the plant vegetation environment and for providing higher yields. The many factors that can cause stress are generally classed as biotic or abiotic in nature.²⁶

- *Abiotic factors* refer to non-living physical and chemical elements in the ecosystem, e.g. elements from the atmosphere or hydrosphere such as water, air, soil, sunlight, and minerals.
- *Biotic factors* are living or once-living organisms in the ecosystem, i.e. factors originating from the biosphere and capable of reproduction. Obvious examples include animals, birds, plants and fungi.

²⁶https://www.researchgate.net/publication/235796708_Comparison_and_Intercalibration_of_Vegetation_Indices_from_Different_Sensors_for_Monitoring_Above-Ground_Plant_Nitrogen_Uptake_in_Winter_Wheat



Figure 63: Chlorophyll measurement with chlorophyll content meter (Source: <https://www.apogeeinstruments.com/applications-and-uses-of-chlorophyll-content-meters/>)

Obtaining various parameters - such as *plan height*, *plant moisture content*, *tiller density* and *dry biomass yield* - from a single pass in the field requires non-destructive, simultaneous methods, and all of these parameters can be measured by many different types of sensors.

- **Laser distance sensors (LDS)** work on the 'triangulation' principle. Point-wise measurements, with a high frame rate, are taken by the sensor which delivers data with a high resolution covering a small section of the plants. This is used in the determination of plant height and tiller density.
- **3D Time-of-Flight (ToF) cameras** are sensors that provide instantaneous three-dimensional information about plants. In comparison to other techniques - such as stereo imaging, laser line methods or laser scanners - further reconstructions are not necessary which subsequently reduce the complexity of the generated data sets. With resolutions of 50×64 pixels these sensors are suitable for dynamic outdoor plant phenotyping, i.e. determining the physical or biochemical characteristics of an organism, by both genetic makeup and environmental influences.
- **Light curtain (LC) imaging** sensors are a recently introduced phenotyping technology, which have been used successfully to assess canopy heights in the field. Sensors record whether the light beams are interrupted by an object, e.g. the growing plants. Analysing light through this sensor is suitable for measuring plant height as well as dry biomass determination.
- **Hyperspectral imaging (HSI)** sensors can be used for in-situ plant moisture content determination and measuring the nitrogen status of plants. It is therefore an important extension of the above-described sensors.²⁷

11.4.6 PLANT PROTECTION SENSORS

Globally the agricultural industry incurs major economic losses due to plant disease.

The scale of the problem is such that it is essential to continually monitor plant health in order to detect pathogen infestations, and to respond quickly to reduce the spread of any disease. Information gathered from such monitoring can be used to facilitate effective management practices.

One obvious problem to control is that of **weeds**. Site-specific weed control requires knowledge about the spatially-varying weed distributions within a field.

²⁷ <https://www.mdpi.com/1424-8220/13/3/2830>

Weed management can be manual or automated based on analysis of plant samples before farming operations are performed. This approach is called an **offline approach** in weed management. However, such approaches are generally expensive and not feasible for larger areas, since the weed management needs fast reactions for weed control decisions.

For this reason, methods that enables weed control based on data that is generated at higher frequencies (daily, weekly, monthly) are called **online approaches** to weed management.

There are various sensors that can be used in online approaches. Ultrasonic sensors can measure distances based on sound waves with frequencies above human hearing range. The measured travel time of an ultrasonic pulse from the emitter to the object reflecting the pulse back to the sensor is proportional to the distance. Ultrasonic distance measurements differ by the amount of biomass encountered, and this is heavier in fields infested by grass weeds and broad-leaved weeds. By knowing the differences between weed infested and weed-free measurements the level of weed infestations can be estimated. These sensors are relatively cheap and easy to integrate into real-time applications, making detection relatively easy and patch spraying more effective.



Figure 64: Pheromone traps (Source <http://www.trapview.com/en/#products>)

Another potential problem comes from **insects**. Managing and monitoring the insect population is currently a key issue for successful pest management.

Farmers generally perform periodical surveys of insect traps (e.g. pheromone traps that attract specific insects) deployed across their field. This activity can be labour intensive, it is time consuming, and can be costly where pest monitoring is carried out over larger plant areas. These situations benefit greatly from the use of affordable sensor systems capable of doing pest monitoring automatically in an accurate and a more efficient way.

There are a number of low-cost systems, generally consisting of battery-powered wireless image sensors, that accurately monitor pest populations with a higher temporal resolution and a significant reduction of pest monitoring costs - as no human intervention is required during the monitoring process.

These types of sensor can be deployed in widely differing circumstances – from small monitoring areas (e.g. greenhouses) as well as in large plantations. These low-cost wireless image sensors (less than €100 per sensor) also have a very low-power consumption, offering near-zero maintenance over the operational life of the sensor (approx. 25 years). Their high temporal resolution for trap monitoring data can be programmed to suit particular needs, and the trap monitoring data can be made available in real time via an Internet connection.²⁸

For plant protection there are many specific sensors, as well as configurations of several sensors that are not directly focused on plant protection but usable as a bundle supported with software to analyse the information for particular needs. These include:

²⁸ <https://www.mdpi.com/1424-8220/12/11/15801>

- **lateral flow devices** – simple, low-cost, portable detection devices popular in agriculture, food and environmental sciences – can deliver real time data used to effectively detect early infections in plants.
- **biosensors** - based on 'phage' displays, a technique for the production and screening of novel proteins and polypeptides. New protein appears in the surface coating of the phage (plant), which can then be manipulated and tested for biological activity.
- **biophotonics** sensors - can also promptly detect infections or problems of water drought. Importantly these are non-destructive methods developed to measure the biochemical compounds of a plant leaf, for example by using an infrared spectroscopy technique. Another important advantage is that they are generally very simple tests allowing measurements to be performed in situ. Some of the most promising sensors in this area are **thermography, chlorophyll fluorescence and hyperspectral sensors**.²⁹

11.4.7 YIELD SENSORS

In precision agriculture, **yield-mapping** technology represents an important research area because yield maps display crop responses to all the management techniques applied, and so helps to identify the causes and effects of yield variability.

For example, a **combine grain flow model** is needed to generate a yield map so that the amount of grain can be measured by a **yield sensor** on a combine (harvester) mapping the location of that grain in the field.³⁰

Definition

A **dynamic grain flow model** describes how the grain flow at the end of the threshing process reacts to the feed rate variations during harvest.

Various types of sensors are implemented in yield monitoring technology.

- **The Claas yield-o-meter** operates on a volumetric principle.

This sensor is mounted between the outlet of the clean grain elevator and the inlet of the grain tank bubble auger - which is basically a form of paddle wheel. As the grain reaches a pre-determined level a sensor is activated. The paddle wheel, which is power driven by the combine harvester, rotates in response to the level at which the sensor is activated. The computer counts the number of times grain is discharged from the paddle wheel into the grain tank bubble auger.

The data about the volume of the paddle wheel is stored in the computer, and the volume of grain can therefore be calculated by multiplying the fixed volume of the paddle wheel by the number of paddle wheel revolutions.

Manual calibration of crop density must be pre-programmed into the yield sensor's computer, which is then used to convert volume of grain into mass.

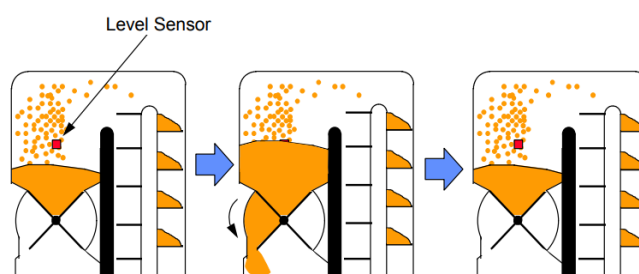

²⁹ <http://cdn.intechopen.com/pdfs-wm/37530.pdf>

³⁰ <https://www.ncbi.nlm.nih.gov/pmc/articles/PMC3927513/>

- **The Ceres volumetric system** is based on a design by Claas GmbH, Germany, but not integrated into a specific combine harvester as it can be retro fitted to any machine.

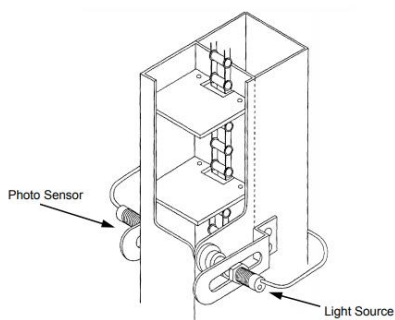

A light source is mounted as high as possible on one side of the clean grain elevator. A photosensor is mounted on the opposite side of the elevator which determines whether or not it can detect light from the light source. The light source and *photosensor* indirectly measures the height of grain on each paddle as it travels up the elevator. The greater the yield, the higher the height of grain on each paddle, and hence the less time the *photosensor* detects light as the paddle passes.

Recording the time that the *photosensor* does not see light, the computer converts this time measurement into a value equating to the height of grain on the elevator paddle. From this, the computer can then calculate the two-dimensional cross section area of grain carried by the elevator flights, which is then converted into volume (three dimensional). Finally, the computer calculates the mass of grain. Again, the density of the crop measured has to be pre-programmed into the computer.

- **The Flow Control system**, as used by Massey Ferguson for measuring yield, is fully integrated into the combines' electronic systems.

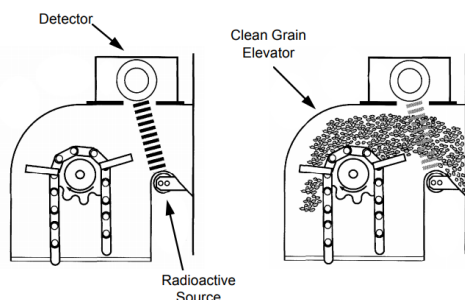

Though using different detector techniques, the principles are the same as for volumetric systems. A gamma source is mounted below the clean grains elevator head and forms a window of gamma rays that the harvested crop flows through. Mounted on the opposite side of the elevator is the detector unit, which measures the level of the gamma rays as they exit the elevator.

With no grain flowing through the combine, the detector is receiving the maximum level of gamma rays (approx. 30,000 counts per second) from the source. As harvesting commences, grain passing between the gamma source and detector block some of the radiation, and the level of gamma rays is therefore reduced (e.g. 25,000 counts per second). The reduction in gamma rays (e.g. 5,000 counts per second) is measured by the detector.

- **The Micro-Trak yield sensor** is a system that can be retro-fitted to a large number of different combines.

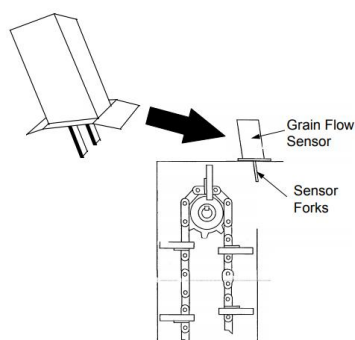

The yield sensor, which is installed on the clean grain elevator, records the flow of grain by measuring the force applied to a sealed load cell. Sensor forks extend through the top of the clean grain elevator into the flow of grain. As grain moves past the forks, from the clean grain elevator to grain tank bubble auger and a force is applied to the sensor. The amount of force is dependent on the flow of grain so the greater the flow of grain the more force is applied to the sensor forks.

This depends on the speed of the elevator: a faster elevator speed will produce a greater force on the sensor forks. As force is applied, a frequency is generated and sent to an electronic module. The frequency is compared to calibration values and converted into yield.

The data yield is relayed to a console in the combine cab where it is displayed to the operator.

- **The Ag-leader 2000 yield sensor** operates on a similar principle to that of the Micro-Trak system. Mounted in the top of the clean grains elevator is an impact plate, which forms the basis of the measuring device. The grain leaving the elevator is deflected towards the grain box and then augured into the grain tank with the aid of the bubble auger.



The deflection of the grain flow is caused by the impact and friction forces between the impact plate and grains. To measure the force, the curved plate is mounted on a force transducer which transforms the force into a voltage which acts as the signal output. The speed of the grain impacting the plate is partially controlled by the speed of the elevator.

To compensate for any change in force because of changes in elevator velocity, the speed of the elevator is monitored. The force is compared to calibration curves held within the system's computer and the signal output is converted into a mass flow rate.³¹

11.4.8 LIVESTOCK SENSORS

Precision agriculture for livestock is largely about measuring and managing the variability of biological resources at the individual animal level.

Using on-farm sensor applications as a part of a precision livestock farming can help farmers to monitor and react quickly to everyday needs in the animal husbandry business. Livestock sensors are used predominantly with ruminant livestock, more accurate dairy cows. Information collected from the sensors provide a valuable data the farmers, enabling them to be accurate with their subsequent business decision making.

There are several sensors on the market which, when combined, form a complete set of tools for tracking different activities and conditions in livestock monitoring.

- **Electronic identification**
Any full implementation of a precise livestock farming (PFL) approach requires the automatic identification of individual animals. This is the 'backbone' of all PFL systems.
- **Leg-mounted accelerometers**
These sensors are used in several areas - such as on-farm 'estrus' (heat) detection and health monitoring - by recording activity, steps, and lying and standing behaviour. Accelerometer systems available now on the market include:
 - **Agis Automatising Sensor** operates by monitoring the eating, ruminating, resting and active behaviours based on ear movement
 - **Silent Herdsman 'health alerts'** operates by detecting the eating and rumination behaviours, based on an accelerometer positioned on the neck of the ruminant
 - **Needap Smarttag neck** is an accelerometer based on monitoring the eating and grazing activities of animals.

³¹http://www.ufrj.br/institutos/it/deng/varella/Downloads/IT190_principios_em_agricultura_de_precisao/literatura/thesis%20moore/Yield%20sensors.pdf

11.4.9 AIRBORNE SENSORS (UAVS)

There are two main reasons to for utilizing airborne sensors in agriculture:

- monitoring the state of plants and health of their growth
- the application of substances to aid plant growth.

Definition

An Unmanned Aerial Vehicle (UAV) is an aircraft piloted by remote control or by on-board computers.

While satellite imagery has been in use for some years now, flexible, low-cost drone technology has become a more recent and popular means of obtaining airborne sensor information.

DRONES

With the help of **drones** farmers are now able to perform evaluations of their crops at scale while simultaneously creating crop maps that help them manage crops and time in a more effective way than previously possible.

The applications of drones in the agricultural industry fall into four broad categories:

1. crop field scanning using compact multispectral imaging sensors
2. GPS map creation through on-board cameras
3. heavy payload transportation
4. livestock monitoring using thermal-imaging camera-equipped drones.

The benefits of using drones in agriculture are many, but include:

- increasing yields through improved production processes
- efficiency in identifying ad-hoc problems
- increasing crop health awareness and frequency of monitoring.

The advantages of drones are that they can be readily configured for specific needs, and that they can be rapidly deployed. These devices enable farmers to react quickly to conditions in the field, so saving valuable time and resources.

Through generated data - such as precise **orthomosaic maps** (the grouping of many overlapping images of a defined area, processed to create a new, larger mosaic of great detail and in true scale) -farmers can make more informed and sophisticated crop and land management decisions.

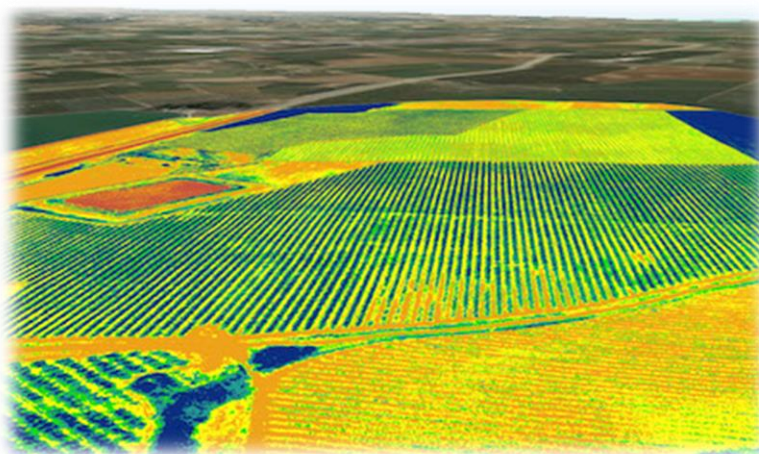

Figure 65: Drone imagery

(Source:<http://www.freshplaza.es/article/3101003/la-agricultura-de-precision-cobra-sentido-con-la-figura-del-asesor-tecnico/>)

Compared with satellite imagery, the use of drones in agriculture and in smart farming gives farmers a very effective way of surveying the terrain and information leading to more precise evaluations. **UAVs** can give farmers a bird's eye view of their fields whilst still remaining close to the ground. This kind of usage offers the opportunity of getting an overall perspective, making for better use of farmer time.³²

UAVs can be also use in applying **plant protection practices**, such as spraying pesticides. Using UAVs in this way minimizes human contact with chemicals – which is good for human health. It can also lead to improved performance and accuracy of the spraying operation, the avoidance of chemical presence neighbouring fields, and in preserving natural areas and water sources³³

There are two basic types of drones:

- **Drones with multicopters.** The main advantage of this type of drones is the potential of holding the UAV at one spot in the air (hovering) to get more accurate data for specific areas of the field
- **Drones with fixed wings.** The main advantage of these drones is the potential of mapping large agricultural areas by autonomous flight

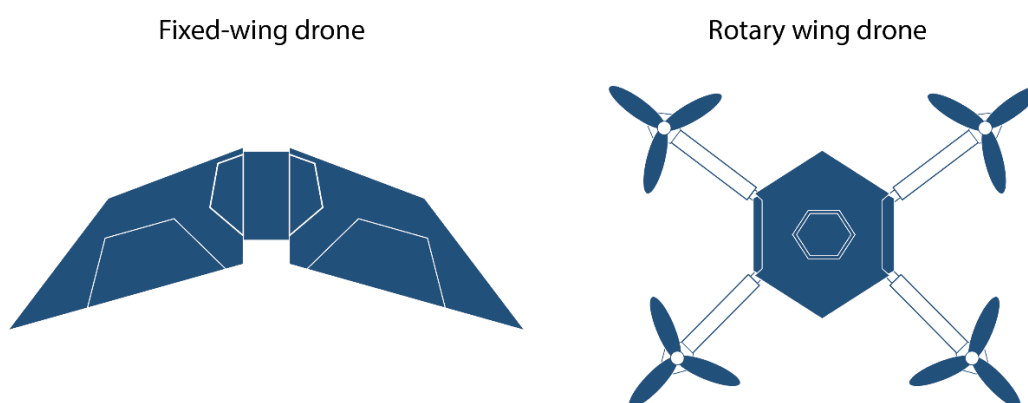

Figure 66: Source: <http://www.globaltroxler.ca/blog/2017/10/11/drones-fixed-vs-rotary/>

11.4.10 APPLIED SENSORS ON AGRICULTURAL MACHINERY

Many activities connected with **Agriculture 4.0** involve the use of smart electronic devices, combined with different high-tech algorithms to support decisions support systems in farming businesses.

All of the activities that are connected with precision agriculture are enabled via microelectromechanical system (MEMS), in which the driving force are sensors. Sensors allow data generation, and hence data processing, for different monitoring layers in the farming. <https://www.agriculture.com/technology/data/sensors-will-profoundly-change-agriculture-decision-making>

Definition

Microelectromechanical system (MEMS) is a process technology used to create tiny integrated devices or systems that combine mechanical and electrical components.

³²https://www.researchgate.net/profile/Emanuele_Ruffaldi2/publication/280156490_Towards_Smart_Farming_and_Sustainable_Agriculture_with_Drones/links/56144be308ae4ce3cc63a738/Towards-Smart-Farming-and-Sustainable-Agriculture-with-Drones.pdf

³³ <http://www.producao.usp.br/bitstream/handle/BDPI/48891/2689943.pdf?sequence=1&isAllowed=y>

Several types of sensors are present in smart machines³⁴:

- **Inclination sensors** that monitor the vehicle's inclination angle
- **Capacitive sensors** that allow increased machine efficiency by regulating the motor speed, and increased machine safety via operator controls
- **Ultrasonic sensors** that monitor a constant spray nozzle height above the ground to ensure optimized fertilizer spreading.



Figure 67: Source <http://www.cema-agri.org/page/%E2%80%98farming-40%E2%80%99-farm-gatase>

11.5 OPEN DATA SOURCES

In this section you will learn about:

- *open data sources and sharing*
- *satellite imaging, including Copernicus & Sentinel space missions*
- *types of Spectral indices*
- *the basics of Orthophotos imaging.*

Technology changes rapidly, making it difficult at times for overall technological developments to keep up with the potential of technology.

Openly sharing information has been around for centuries, and this very principle of information sharing within the general community has been a key driver in the development of tools and machinery. This is particularly true in IT and computing, and it has proved extremely important for various developments in agriculture.

Open data sources lead to consistency of analysis which can assist all stakeholders within the complex agro-food industry to make better decisions.

Definition

Open source data sharing means that the data is available for everyone to download, analyse, update, and contribute to.

³⁴ <https://www.pepperl-fuchs.com/global/en/18769.htm>

11.6 REMOTE SENSING TECHNOLOGY

Remote sensing technology has been in use in agriculture since the late 1960s, and can be an invaluable tool when it comes to monitoring and managing land, water, and other resources.

Remote sensing can help identify and measure many factors, from stressing at specific points in a crop's growing cycle to estimating the amount of moisture in the soil. Remote sensing data unquestionably enriches decision-making on the farm and can come from a number of sources, including drones and satellites.

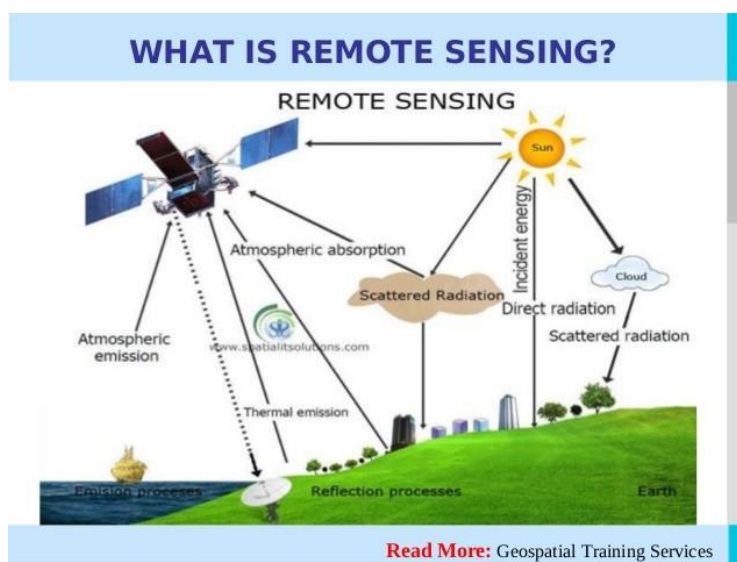

Figure 68: Source: <https://www.baltic-transcoast.uni-rostock.de/news/news-2018-2017/remote-sensing-class-2017/>

11.6.1 GIS & GPS

GPS soil sampling – testing a field's soil characteristics - reveals details of the available nutrients, pH levels, and a range of other data important for making informed and profitable decisions.

Soil sampling allows growers to consider productivity differences within a field and formulate plans that take these differences into account. Collection and sampling services allow the data to be used for input for variable rate applications, e.g. for optimizing seeding and fertilizer.

Precision agriculture was basically born out of the introduction of GPS guidance for (initially John Deere) tractors in the early 1990s, and the adoption of this technology is now so widespread globally that it's probably the most commonly-used example of precision agriculture today. GPS-connected controllers in tractors can automatically steer the equipment, based on knowledge of the coordinates of a field. This can reduce steering errors by drivers as well as overlap passes in the field, resulting in less wasted seed, fertilizer, fuel, and time.

Definition

A geographic information system (GIS) integrates hardware, software, and data for capturing, managing, analysing, and displaying all forms of geographically referenced information.

Though the underlying systems may perform some quite complicated analytical functions, **GIS** can present results that can be visually evaluated in form of simple maps, tables or graphs - allowing the

farmer to virtually see and predicting issues based on the underlying information. Ready visualization supports accurate decision-making and other courses of action.

Use of **GIS** in agriculture has advanced significantly since it was first used in the mid- 1990s, with quite widespread use now (Corwin & Lesch, 2003). **GIS** in farming has become essential for precision agriculture, where issues such as soil sampling have become an evolving management practice (Flowers et al., 2005, Van Schilfgaarde, 1999). **GIS** is now an integral component in the delivery and further refinement of novel techniques in soil sampling and other processes.³⁵

GIS captures, stores, manipulates, analyses, manages, and presents all types of geographical data. Though often used as a term for the academic discipline, or career, of working with geographic information systems, **GIS** is really a fusion of cartography, statistical analysis, and database technology – all applied to sectors such as agriculture. Making farming decisions are based on geography and spatial phenomenon. By understanding the geography and the location, overall ideas of environmental, administrative and social needs can be established.

By helping farmers to increase their production, but reduce the costs of managing the land in an efficient way, **GIS** plays a major role in today's agriculture production. It has a fundamental influence in the success and profitability of a farming business by offering a balancing between the inputs and outputs of the farm.

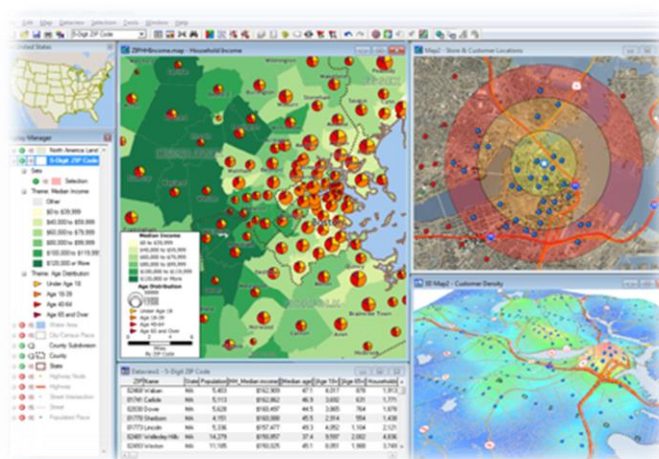

Figure 69: GIS software (Source: https://www.caliper.com/maptitude/gis_software/default.htm)

GIS outputs are generally portrayed through three principle views;

1. Database View. A **GIS** is a unique kind of database of the world - a geographic or georeferenced database. All data are expressed with longitude and latitude coordinates, with the objective of creating digitalized maps.
2. Map View. **GIS** output can be represented as a set of intelligent and interactive maps, with views showing features and feature relationships on the earth's surface. These maps are used like 'windows into the database' to support queries, analysis, and editing of the information.
3. Model View. **GIS** also provide a set of information transformation tools that derive new geographic datasets from existing data sets. These geo-processing functions take information from existing data sets, apply analytic functions, and record results into new, derived datasets for various potential uses.³⁶

³⁵ Knowles, O. & Dawson, A., 2018. Current soil sampling methods

³⁶ <https://www.researchgate.net/publication/260487520>

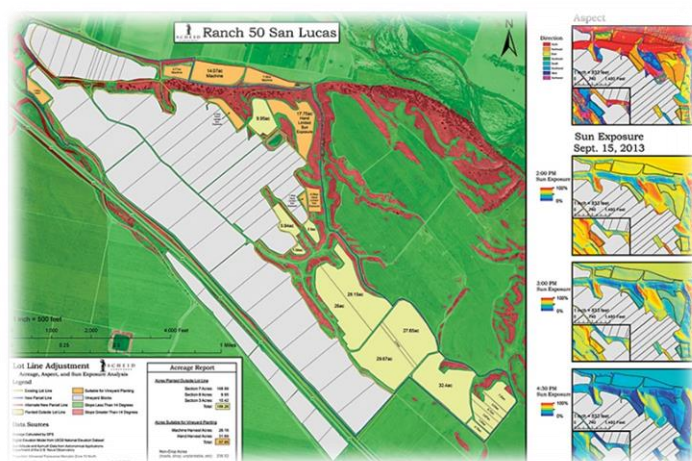

Figure 70: GIS Platform Imagery (Source: <http://www.esri.com/esri-news/arcnews/fall13articles/world-class-vineyard-uses-gis-to-finetune-all-its-operations>)

11.6.2 GPS

The **GPS** space segment consists of a 'constellation' of satellites transmitting radio signals to users. **GPS** satellites fly in medium Earth orbit (MEO) at an altitude of approximately 20,200 km, with each satellite circling the Earth twice a day.

Definition

The Global Positioning System (GPS) is a U.S.-owned utility that provides users with positioning, navigation, and timing (PNT) services. This system consists of three segments: the space segment, the control segment, and the user segment.

The **GPS** control segment consists of a global network of ground facilities that track the **GPS** satellites, monitor their transmissions, perform analyses, and send commands and data to the constellation.

Like the Internet, **GPS** has become an essential element of today's global information infrastructure. The free, open, and dependable nature of **GPS** has led to the development of hundreds of applications affecting every aspect of modern life. **GPS** technology is now in everything from cell phones and wristwatches to bulldozers, shipping containers, and ATM's.

GPS boosts productivity across a wide swath of the economy, including farming, construction, mining, surveying, package delivery, and logistical supply chain management. Major communications networks, banking systems, financial markets, and power grids depend heavily on **GPS** for precise time synchronization. Indeed, many wireless services cannot operate without it.³⁷

By combining the **Global Positioning System (GPS)** and **geographic information systems (GIS)** the implementation and development of precision agriculture has been made viable. These technologies enable the coupling of real-time data collection with accurate positional information, leading to the efficient manipulation and analysis of large amounts of geospatial data.

Diverse areas of farming operation – such as farm planning, field mapping, soil sampling, tractor guidance, crop scouting, variable rate applications, and yield mapping - are made possible through GPS-based application. GPS applications can even allow farmers to work during unpleasant weather conditions such as rain, dust, fog and darkness where visibility of the field is minimal.

³⁷ <https://www.gps.gov/>

Data collected on location information mapping field boundaries, road locations, irrigation systems, and problem areas in crops (such as weeds or disease), can be combined with GPS data and used for navigating specific locations, building histories of processes, collecting histories of soil samples, and monitoring crop conditions.³⁸

11.7 SATELLITE IMAGE AND SPATIAL DATA

Today's **remote sensing (RS)** technologies are an essential tool in precision agriculture. It provides accurate and reliable data – in real-time – on various measures and over large areas that directly supports more efficient and effective decision-making on the farm.

Remote sensing technologies include:

- orbiting satellites
- airborne devices, such as planes, helicopters, balloons or drones.

The most common operations supported by the remote sensing technologies in agriculture are:

- farming planning activities
- comparisons of the current state with historical data.

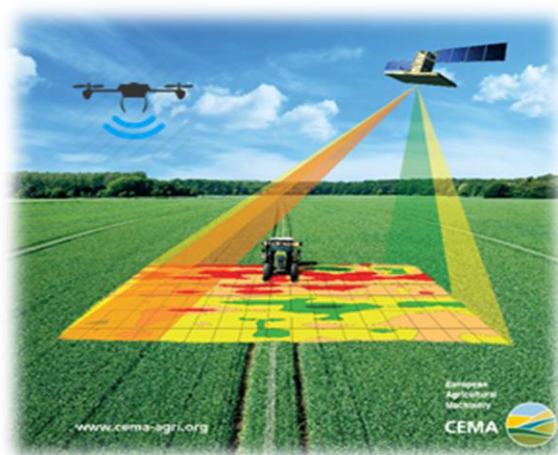

Figure 71: Source: <http://www.cema-agri.org/file/3324>

11.7.1 EUROPEAN IMAGING SOURCES: COPERNICUS

In Europe, the EU is committed to optimizing the use of satellite data in farming with the overall aim of improving farming practices, water resource efficiency and crop yields.

Its Copernicus remote sensing programme, and in particular Sentinel-2, provides detailed imaging useful for a variety of purposes through accurate and timely information on crops and farmland. For example, these images can be used to distinguish between different crop types or used to monitor plant growth.

Remote sensing, via Copernicus Sentinels, can help to simplify and modernise aspects of the Common Agricultural Policy (CAP) particularly in areas of sustainability, environmental protection, biodiversity and the climate. It can also bring simpler bureaucracy and increases efficiency for farmers in areas such as monitoring as data from Copernicus Sentinels (and other observation systems) can replace physical visits to farms and checks necessary for the EU to issue payments to farmers.

The European Commission fund Copernicus, though specialized bodies provide the technical implementation – [ESA](#) (European Space Agency), [EUMETSAT](#) (European Organisation for the Exploitation of Meteorological Satellites), [EEA](#) (European environment Agency), [ECMWF](#) (European Centre for Medium-Range Weather Forecasts).

³⁸ <https://www.gps.gov/applications/agriculture/>

Copernicus was discussed earlier in Module 2.

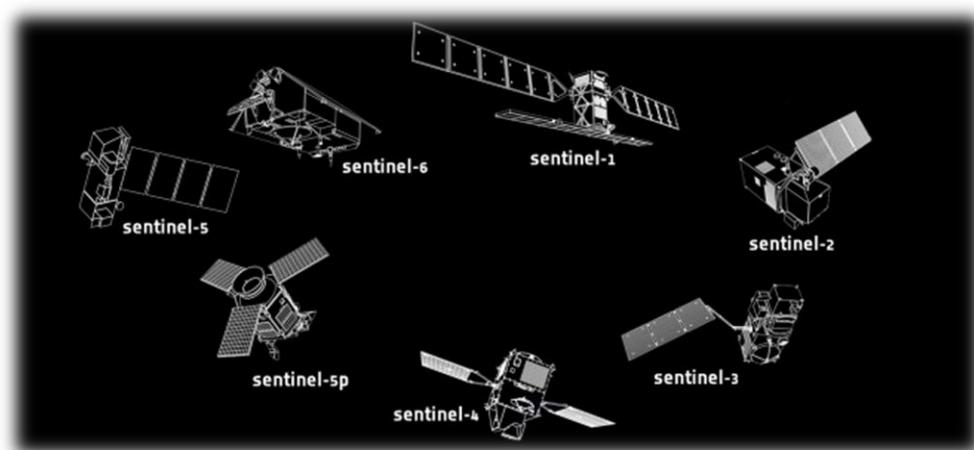

Figure 72: Source: <https://gisgeography.com/sentinel-satellites-copernicus-programme/>

11.7.2 SENTINEL MISSIONS

The EU and the ESA are currently developing seven missions under the Sentinel programme.

The Sentinel missions include radar and super-spectral imaging for land, ocean and atmospheric monitoring. Each Sentinel mission comprises a 'constellation' of two satellites to fulfil and revisit the coverage requirements for each mission, hence providing reliable datasets.

Sentinels 1 & 2 have specific agricultural objectives:

1. Sentinel-1 will provide all-weather, day and night radar imaging for land and ocean services.
2. Sentinel-2 will provide high-resolution optical imaging for land services, including imagery of vegetation, soil and water cover, inland waterways and coastal areas.

Sentinel-1 and Sentinel-2 missions will support the development of the CAP, hopefully relieving farmers of chores that divert attention from farming and food production. These two Sentinels offer a wealth of complementary, up to date information - covering Europe every 3–4 days:

- Sentinel-1's radars provide data on crop biomass and details of when a crop has been harvested.
- Sentinel-2 carries high-resolution cameras, whose images can be used to distinguish between different crop types, assess crop health and monitor land-use change.

Crop monitoring is relevant for crop diversification – important to farmers and their eligibility for CAP payments. There is an obligation to grow a variety of crops, depending on the size of a farm. Sentinels 1 & 2 can monitor the relevant farming activities and crop state to identify the types of crop being planted, how they grow throughout the growing season, and when they are harvested.

11.8 SPECTRAL INDICES

The structure and physiology of vegetation and individual plants influence their 'spectral reflectance', i.e. the amount of reflected radiation they give off at various wavelengths.

Images displayed in the visible part of the spectrum (RGB) provides some, but limited, information about the state of a crop. In order to view information not detectable by the naked eye, it is necessary to use a combination of individual spectral bands (e.g. infra-red or ultra-violet) for a given set of data.

Such band combinations are called spectral or vegetation indices. Each index has its own purpose.

- **Broadband indices** use bands from multispectral cameras and depend primarily on the spectral resolution of the image.
- **Spectral indices** generally include a combination of bands where high reflectance (**Green** and **Near Infra-Red** bands) or bands where electromagnetic radiation can be detected, e.g. **Red**.

11.8.1 USE OF SATELLITE IMAGES IN AGRICULTURAL PRODUCTION

The use of images from **Sentinel-2** and **Landsat** satellites can be subdivided into plant and livestock production.

These two directions, however, are very closely related. Images can be used to model and calculate spectral indices and can be used equally well for visualization in the form of colour synthesis, whether in the visible part of the spectrum, or with inclusion of other wavelength ranges.

11.9 USABILITY OF INDIVIDUAL SPECTRAL BANDS IN AGRICULTURAL PRODUCTION

There are a number of specific spectral bands used for specific usage.

The main ones, and their uses, are:

Spectral band	Usage
Blue	Differentiating vegetation from bare soil
Green	Green vegetation characteristics, local maximum of reflectiveness
Red	Differentiating vegetation from bare soil; absorption band
Vegetation Red Edge	Increase in reflectiveness from vegetation, determining vegetation health
NIR	Identifying plant species, vegetation health, biomass volume, soil humidity
SWIR1	Identify the amount of water in plants, water stress
SWIR2	Identify the amount of water in plants, water stress

11.9.1 SPECTRAL INDICES

Properly chosen colour synthesis can point to possible plant stress or soil erosion based on different colour shades – in addition to the monitoring of healthy and prosperous growth of the plant.

Spectral indices are combinations of spectral reflectance from two or more wavelengths to indicate features of interest. Vegetation indices are obviously commonly used in agriculture, but other indices are available for burned areas, man-made (built-up) features, water, and other geologic features.

Usable spectral indices in plant production include:

- **NDVI** (*Normalized Difference Vegetation Index*)
- **EVI** (*Enhanced Vegetation Index*)
- **RENDVI** or **NDRE** (*Red Edge Normalized Difference Vegetation Index*)
- **GNDVI** (*Green Normalized Difference Vegetation Index*)
- **MSI** or **NDWI** (*Moisture Stress Index*)

LAI (*Leaf Area Index*).

NDVI is one of the most used indices and is commonly used for an initial view of the state of the crop.

Other indices work with similar characteristics, so their results are correspondingly similar to that of **NDVI**. However, they differ in their detailed views of the state of the vegetation.

In order to be able to make use of observations of crop types across sites it is important to work with the history of the development of vegetation on specific plots.

- **NDVI (Normalized Difference Vegetation Index)**

This index is a measure of healthy, green vegetation, and is generally the most widely used index. Photosynthesis requires water, carbon dioxide and light in order to produce sugars and oxygen. Chlorophyll, which gives plants their green colour, absorbs visible light. Leaves reflect near-infrared light (NIR) and use only visible light for photosynthesis. This means that a healthy plant with good photosynthesis activity can be analyzed by comparing NIR with visible red light.

Unhealthy vegetation will reflect more visible light and less NIR. Healthy vegetation will absorb most of the visible light falling on it.

NDVI is, however, sensitive to the effects of soil (brightness and colour), cloud cover and shadow, and leaf canopy shadow. It is also inaccurate for dense vegetation.

- **EVI (Enhanced Vegetation Index)**

This index is the standard for *Moderate Resolution Imaging Spectroradiometers* – instrument used on the Terra and Aqua satellites. An alternative to NDVI, it addresses some of its shortcomings, e.g. soil and atmospheric limitations, by optimizing the leaf-level reflectivity of vegetation. It uses the blue part of the signal correction spectrum, which can be influenced by the reflection of the soil, and it reduces the impact of the atmosphere, including electromagnetic radiation scattering due to aerosols.

- **RENDVI (Red Edge Normalized Difference Vegetation Index)**

This index is based on the traditional **NDVI** index but with modifications. It is particularly useful in precision farming, for forest monitoring and for vegetation stress detection. Its effectiveness is due to the inclusion of wavelengths falling into the red edge region instead of the wavelengths corresponding to the maximum reflection and absorption value. It is particularly suitable for detecting minor changes in the vegetation state.

- **GNDVI (Green Normalized Difference Vegetation Index)**

This index is similar to the **NDVI** index, with the difference that it measures the reflectance in the green part of the spectrum in the wavelength range 540 to 570 nano-meters instead of the red part of the spectrum. This makes the index more sensitive to chlorophyll content.

- **MSI (Moisture Stress Index)**

This index is sensitive to the increase in water content in leaves.

The **MSI** index is used to detect stress with water scarcity, and is a good predictor of profitability, and is often used for modelling crop conditions, fire hazard analysis, and in ecosystem physiology studies. The **MSI** index is inverse to other indexes that measure the water content. High values indicate greater water stress and less water content.

- **LAI (Leaf Area Index)**

This index is used to estimate the area of leaves and to predict crop growth and yield.

11.10 ORTOPHOTOS

In precision agriculture, the generation of aerial images with high spatial resolution is particularly useful, particularly aerial images in the visible (**VIS**) and near-infrared (**NIR**) spectrum.

Definition

An **orthophoto** (ortho image) is an image which has been 'corrected' for the geometric distortions (different projection, lens/sensor distortion, relief) so that it can be used as a map.

Orthophoto image are combined and analysed with other maps and images from geographic information systems (GIS) systems to determine the status of plants in the field.

The ortho-rectification of aerial and satellite images is particular important because:

- The high resolution of images available today makes the distortions of unprocessed images unacceptable as images from different platforms and sensors are often combined and with spatial information coming from other sources (e.g. GPS, cartography).
- Geometric corrections are due to:
 - platforms and sensors, e.g. sensor geometry and positioning instruments accuracy (GPS, inertial systems, gyroscopes, etc.)
 - observed objects, e.g. object geometry and atmospheric distortions
 - cartographic projections - mapping the earth's surface (an ellipsoid) to a flat plane.

Usually all three types of corrections must be applied, though in some cases simplifications are possible, for example when a flat terrain is observed.³⁹

Orthophotographs are photographic images constructed from vertical or near vertical aerial photographs. The processes used to generate **orthophotos** remove distorting effects such terrain relief displacement and aircraft tilt.

11.11 WEATHER DATA AND FORECAST

Almost every National Hydro Meteorological Institute provides, not only an overview of the current weather conditions and short and long-term forecasts, but also open data that can be used in other applications for determine key parameters in crop management.

As well as data from national organizations, there are a number of applications and tools that provide information about immediate weather situations, and forecasts for any place on Earth. These applications make it very easy to obtain basic weather information.

Some of the most widely used applications and tools are *YR*, *Windy*, *OpenWeatherMap*, etc.

These widely used tools are not just available as web-based applications, but they are also available as native applications for Android and iOS mobile/smartphone platforms - providing open data ready for import into applications of precision agriculture.

This data can be provided in a wide range of formats, including through specialized software interfaces (APIs) for direct import into systems.

³⁹ http://www.ing.unith.it/~zatelli/remote_sensing/Ortophoto.pdf

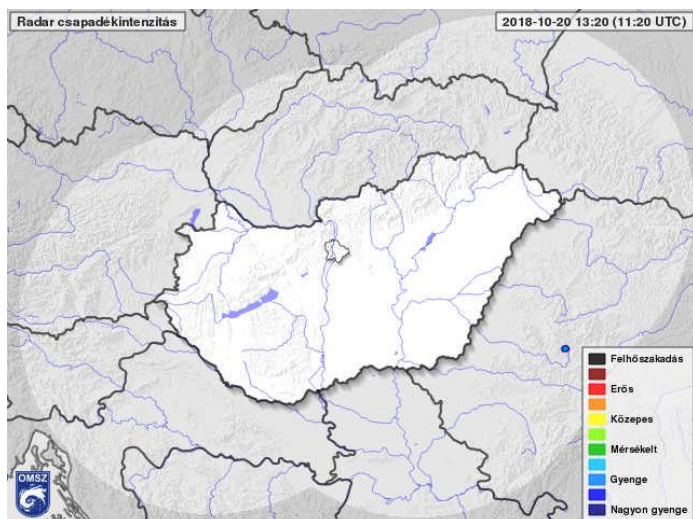

Figure 73: Example of radar overview by OMSZ (met.hu, 2018)

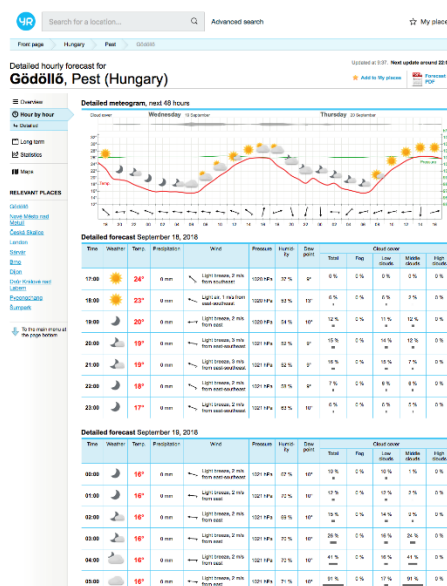

Figure 74: Example of YR application (yr.no, 2018)

```
<?xml version="1.0" encoding="utf-8"?>
<weatherdata>
  <location>
    <name>Gödöllő</name>
    <type>City</type>
    <country>Hungary</country>
    <timezone id="Europe/Budapest" utffsetMinutes="120" />
    <location altitude="210" latitude="47.59657" longitude="19.35515" geobase="geonames" geobaseid="3052236" />
  </location>
  <credit>
    <!-- In order to use the free weather data from yr.no, you HAVE to display
    the following text clearly visible on your web page. The text should be a
    link to the specified URL.-->
    <!-- Please read more about our conditions and guidelines at http://om.yr.no/verdata/ English explanation at http://om.yr.no/verdata/free-weather-data/-->
    <link text="Weather forecast from Yr, delivered by the Norwegian Meteorological Institute and the NRK" url="http://www.yr.no/place/Hungary/Pest/Godolló/" />
  </credit>
  <links>
    <link id="xmlSource" url="http://www.yr.no/place/Hungary/Pest/Godolló/forecast.xml" />
    <link id="xmlSourceHourByHour" url="http://www.yr.no/place/Hungary/Pest/Godolló/forecast_hour_by_hour.xml" />
    <link id="overview" url="http://www.yr.no/place/Hungary/Pest/Godolló/" />
    <link id="hourByHour" url="http://www.yr.no/place/Hungary/Pest/Godolló/hour_by_hour" />
    <link id="longTermForecast" url="http://www.yr.no/place/Hungary/Pest/Godolló/long" />
  </links>
  <meta>
    <lastupdate>2018-10-17T09:37:04</lastupdate>
    <nextupdate>2018-10-17T22:00:00</nextupdate>
  </meta>
  <sun rise="2018-10-17T07:03:57" set="2018-10-17T17:51:13" />
  <forecast>
    <tabular>
      <time from="2018-10-17T15:00:00" to="2018-10-17T18:00:00" period="2">
        <!-- Valid from 2018-10-17T15:00:00 to 2018-10-17T18:00:00 -->
        <symbol number="3" numberEx="3" name="Partly cloudy" var="03d" />
        <precipitation value="0" />
        <!-- Valid at 2018-10-17T15:00:00 -->
        <windDirection deg="112.9" code="ESE" name="East-southeast" />
        <windSpeed mps="2.6" name="Light breeze" />
        <temperature unit="celsius" value="21" />
        <pressure unit="hPa" value="1020.8" />
      </time>
      <time from="2018-10-17T18:00:00" to="2018-10-18T00:00:00" period="3">
        <!-- Valid from 2018-10-17T18:00:00 to 2018-10-18T00:00:00 -->

```

Figure 75: Example of XML file – forecast for Gödöllő region (yr.no, 2018)

In Agriculture 4.0, the focus is on web applications that can help farmers plan individual agronomic interventions or manage simple operations, such as irrigation. These applications are based on data coming from different sources, such sensor data, numerical models and data and hydrometeorological institutions forecasts.

12 THE INTERNET OF THINGS (IOT) & AGRICULTURE

In this section you will learn about:

- *the IoT, its main objectives and working principles*
- *trends, benefits and challenges of using IoTs*
- *types of agricultural IoT, and examples of their implementation and usage.*

Enabling communication between machines, and inserting digital intelligence into devices, opens up the opportunity to connect billions of physical devices and to share data through the internet without human contact.⁴⁰

Connected machines and objects in factories offer the potential for a 'fourth industrial revolution', and experts predict more than half of new businesses will run on the IoT by 2020. IoT applies equally to agriculture.

Basically, the term 'IoT' includes everything connected to the internet, however it is increasingly being thought of as pertaining to objects that 'talk' to each other. This can include everything from simple sensors to smartphones, wearables and computers – but devices that are all connected together.

When connected devices are combined with smart software, as in many automated systems, it is possible to do much more than just gather information, but to analyse it and initiate some action, including learning from a process. The IoT can apply equally to devices on closed private networks, but the concept of the Internet of Things brings those networks together, creating a much more connected world.

Within industrial applications, sensors on product lines can increase efficiency and cut down on waste. One study⁴¹ estimates 35 per cent of US manufacturers are using data from smart sensors within their set-ups already. It is not unreasonable to imagine that agriculture can realise similar efficiencies.

Automated systems are a highly effective way for farmers to monitor crops for their humidity, moisture, temperature and so on. However the first **IoT** application in agriculture was in machine-to-machine communication (M2M), with connection between agricultural machinery through a network while allowing communication from the device to the 'cloud' where data could be stored without human interaction.

Now **IoT**s include a set of sensor networks that connects people, applications and systems, sharing data through **M2M** enabled connectivity.⁴²

Definition

IoT are systems of interrelated computing devices, mechanical and digital machines, objects, animals or people with unique identifiers (UIDs), that have the ability to transfer data over a network without requiring human-to-human or human-to-computer interaction.⁴³

12.1 HOW IOTS WORK

IoT devices share the sensor data they collect by connecting to an **IoT** 'gateway' (a device or software programme that serves as the connection point between the 'cloud' and controllers, sensors and intelligent devices) or other device where data is sent in order to be analysed.

Sometimes, these devices communicate with other related devices and act on the information they get from one another. The devices do most of the work without human intervention, although people can interact with the devices, e.g. to set different configurations, give instructions or to access the data. The

⁴⁰<https://www.zdnet.com/article/what-is-the-internet-of-things-everything-you-need-to-know-about-the-iot-right-now/>

⁴¹ <http://usblogs.pwc.com/industrialinsights/2017/09/18/for-us-manufacturers-the-iiot-future-is-now-part-1/>

⁴² <https://www.iotforall.com/iot-applications-in-agriculture/>

⁴³ <https://internetofthingsagenda.techtarget.com/definition/Internet-of-Things-IoT>

connectivity, networking and communication protocols used with these web-enabled devices largely depend on the specific **IoT** applications deployed in the field.

The Internet of Things (IoT) has the capability to transform the world we live in, much as the World Wide Web has. It may lead to more-efficient industries, connected cars, and smarter cities - all targets for the IoT revolution.

However, the application of technologies such as the IoT in agriculture could have the greatest impact. Why? The global population is set to touch 9.6 billion by 2050. Agriculture will be expected to be able to feed this population, so the farming industry must embrace every technology offering any advantage – including the IoT.

In the face of significant challenges - such as extreme weather conditions, increasing climate changes, and the environmental impacts of intensive farming practices - the demand for more food still has to be met.

'Smart farming' based on IoT technologies will enable growers and farmers to reduce waste and enhance productivity, for example from reducing the quantity of fertilizer utilized to the number of journeys farm vehicles have to make.

12.2 IOT TRENDS & BENEFITS

There are some devices currently designated as IoTs that have been used in agriculture for many years.

They are largely proprietary solutions that can only be used in conjunction with agricultural machinery from the same machine manufacturer. As a result of this proprietary lock-in, the main focus of development in this area is about avoiding and eliminating compatibility issues by using open solutions. Open solutions would allow equipment from different manufacturers to be used with all machinery, independent of manufacturer, and could enhance the potential of the IoT. This would potentially decrease implementation costs and create a foundation for cooperation rather than competition.

Interestingly, the fourth edition of the Internet of Things Solutions World Congress (2018), signalled an expected, increasing interest in the technology, and the range of topics discussed showed that IoT is being embraced by companies in almost every sector. In many application areas, IoT technology has clearly passed from the development phase to the implementation of practical solutions – with positive results being increasingly evident.

However, the congress's thematic areas were in manufacturing, healthcare, connected transport, energy & utilities, buildings & infrastructures and open industry – but not in agriculture.

IoT is following some particular trends:⁴⁴

- **Development trends.** It is estimated that by 2020 approximately 38.5 billion devices will be connected to the Internet
- **Minimizing energy consumption.** There is a need to increase the life span of many IoT devices that are not directly connected to a power supply – something that is particularly relevant for many agricultural sensors, for example
- **Miniaturization of devices.**
- **Device integration.** IoT devices often need to be augmented beyond the basic capabilities built in during manufacture
- **Creating user-friendly solutions for IoT control and settings.**
- **Development of devices based on open hardware.**
- **Security of IoT devices in the field.**

However, there are great potential benefits to be gained from IoT in agriculture, including:

- **Valuable data set.** IoT devices can generate large amounts of reliable data for almost every operation of the farm. This can only but better support decision making locally on farms, but also when aggregated nationally or internationally.

⁴⁴https://www.researchgate.net/publication/299499518_Internet_of_Things_IoT_in_Agriculture_-_Selected_Aspects [accessed Sep 13 2018]

- **Lower production risks.** IoT data sets can providing improved control over production processes, resulting in more effective and efficient planning, with optimal usage of agricultural inputs.
- **Cost management and waste reduction.** Sensor information providing early detection of anomalies in livestock and crop growth will lead to a minimization of the risks of lower yields.
- **Increased business efficiency** – With automation of the farming operation better control is established in the entire production cycle.
- **Enhanced product quality and volumes** –IoT and automation allows enhancement of quality and growth of crops thus achieving higher yields.

12.3 IOT AGRICULTURAL EXAMPLES

IoT is relevant to very many applications in agriculture, including:

- **Weather stations.** Sensors combined within weather stations collect data providing measurements that map climate conditions, inform crop decision making, and potentially help to improve crop capacity, delivering maximum possible yields. By measuring these environmental factors, and generating data from them, the IoTs can build up a precise history that can help farmers with their decision making processes, or to make probabilistic-based plans, thus **lowering the risk of unexpected costs and operations.**



Figure 76: Source: http://www.progressth.org/2016/12/3d-printed-iot-weather-station_26.html

- **Greenhouse automation.** Weather stations are not only used for collecting necessary environmental data but can also be used to automatically adjust conditions in controlled micro climate conditions, such as greenhouses, to match specific growing parameters. Whether the use is for hydroponics or substrate-grown plants, the benefits of automated greenhouses can be significant. Instantaneous data obtained by the sensors can be combined to give a broad picture of the conditions in the greenhouse. If the optimal parameters for optimal growing conditions are known and set, automatic adjustment of the environment is readily achieved.

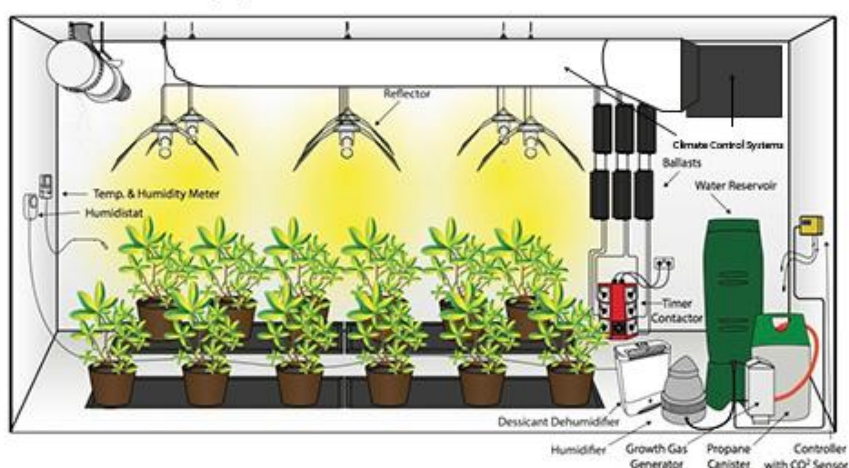

Figure 77: Source: <https://drgreens.co.uk/product/kahn-sentinel-2-climate-control-system-4-x-600w/>

- Crop management devices.** There are a large range of sensors that can be placed in the field to collect decision making information such as temperature, precipitation, crop health, crop nutritional state and many others. These devices are core elements in precision farming. From the sensor measurements, many forms of valuable data can be obtained. When that data is stored, it creates a temporal history that feeds into the decision-making software that helps the farmers in their decision-making processes.

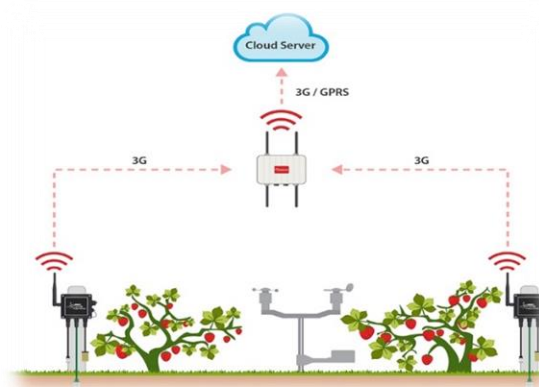

Figure 78: Figure 80: Crop management devices (Source: <http://www.libelium.com/smart-strawberries-crop-increases-the-quality-and-reduces-the-time-from-farm-to-market/>)

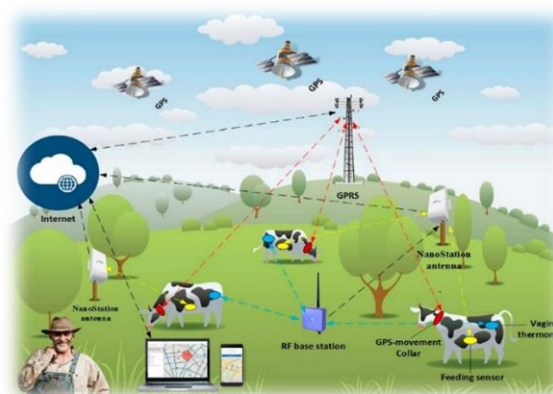

Figure 79: Livestock management devices and their connection (Source: <https://www.pinterest.co.uk/pin/506655026823402877/>)

- Livestock management devices.** Sensors can be applied, or even attached, to animals to provide information on the temperature, health and nutritious insight of each individual animal, as well as overall information about the herd. With this kind of sensor, the farmer knows exactly where specific animals with unique identifiers are. The sensors can also provide information such as when a specific animal last ate, slept, walked, etc.
- Farm productivity management systems.** There are many potential systems that monitor and control all sensors installed in the field, combining to provide a powerful analytical dashboard for logistics, accounting and reporting functions. By knowing the exact inputs and outputs used

across the farm, farmers can obtain a clear of potential risks that they might face, but have information to hand to help with formulating optimal solution.

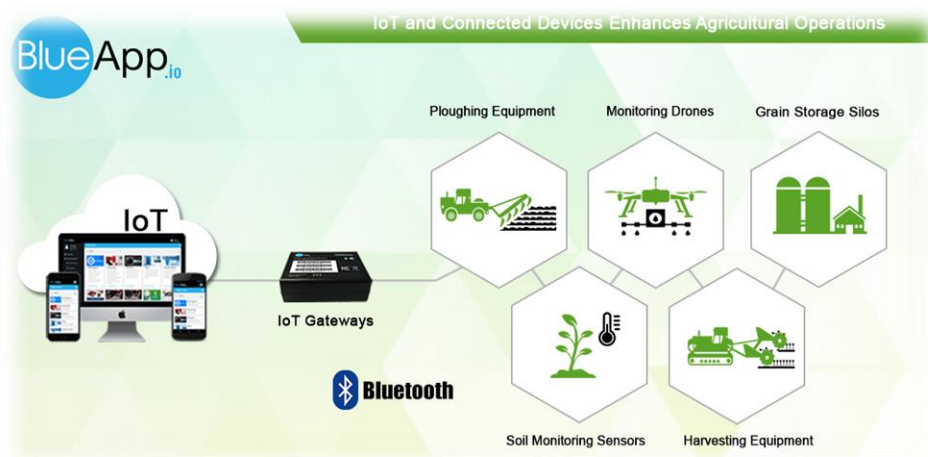

Figure 80: Source: <http://blueapp.io/blog/the-internet-of-things-solutions-for-smart-agricultural-operations/>

13 DIGITAL FARM MANAGEMENT EQUIPMENT

In this section you will learn about:

- *precision agriculture machinery*
- *implementing precision farming technology in basic agrotechnical operations.*

Digital Farming is about the evolution in agriculture and agricultural engineering, from **Precision Farming** to connected, knowledge-based farm production systems.

Digital Farming makes use of **Precision Farming** technologies, many of which are built on intelligent networks and data management tools.

Definition

The aim in **Digital Farming** is to use all available information and expertise to enable the automation of sustainable processes in agriculture.

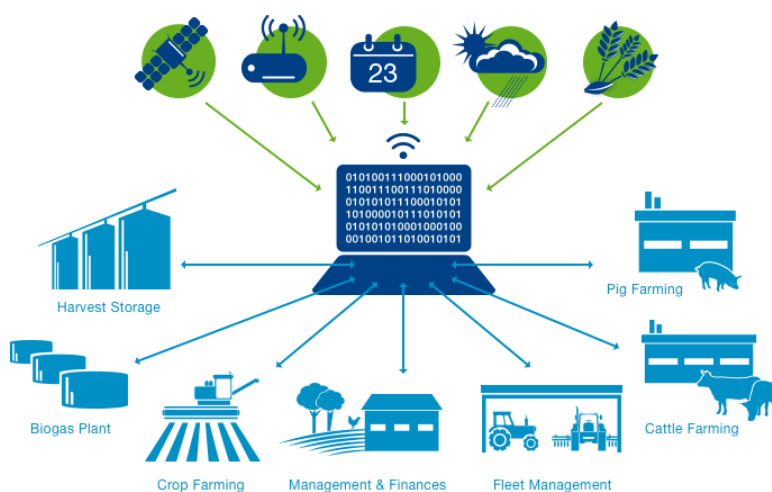

Figure 81: Digital farming (Source: <https://www.cropscience.bayer.com/en/stories/2014/digital-farming-bit-by-bit>)

13.1 PRECISION AGRONOMICS

Precision agronomics - the science of soil management and crop production. - is another important agricultural development involved in combining farming methodologies with technology.

It is basically about providing more accurate farming techniques for planting and growing crops. Precision agronomics takes on the traditional role of an agronomist, but with judicious use of technology it helps make the methods used more accurate and scalable.

The primary aim of precision agriculture and precision agronomics is to ensure profitability, efficiency, and sustainability while protecting the environment. This is achieved by using the data set gathered by the various sensors and technology to guide both immediate and future decision-making on all aspects of farming - from where in the field to apply a particular rate, to when it's best to apply chemical, fertilizer or seed.

While precision agriculture principles have been around for more than 25 years, it's only been over the past decade that they have become mainstream due to technological advancements and the adoption of other, broader technologies. The adoption of mobile devices, access to high-speed internet, low cost and reliable satellites – for positioning and imagery – and farm equipment that's optimized for

precision agriculture by the manufacturer, are some of the key technologies characterizing the trend for precision agriculture. Estimates today suggest that more than 50% of today's farmers use at least one precision farming practice.

At its most basic level, precision agronomics takes the role of an agronomist and helps make the methods they use more accurate and scalable.

13.2 PRECISION AGRICULTURE MACHINERY AND EQUIPMENT

There is an inherent complexity to many agricultural production processes, due in part to the potential multitude of business partners involved, the many different sources of information, and extensive and differentiated communication structures. Digitally smart farm machines must therefore be able to:

- send and receive information via appropriate sensors and communication hardware
- facilitate automated operation
- be configured for optimal utilisation of the machinery
- assist the driver or operator.

At the heart of **Digital Farming** is connected agricultural machinery. The ultimate vision for connected agriculture will be achieved when machines are able to seamlessly talk to each other and to their controlling systems.

To aid this, there are various communications standards. In particular, the **ISOBUS** standard (**ISO standard 11783**) has become the de-facto standard governing interoperability between tractors and other machinery, and it is supported and implemented by most manufacturers.⁴⁵ ISOBUS is a brand name for ISO standard 11783, and it provides an open, interconnected system for on-board electronic systems. It enables multiple electronic control units, connected on via an in-vehicle network, to communicate with each other through a standard protocol. ISOBUS therefore standardizes communication between a tractor control unit, implement control units, and virtual terminals and/or web-based or mobile phone applications.

ISOBUS is key to ensuring interoperability between control units and machinery manufactured by different equipment manufacturers and automotive suppliers. This compatibility is essential to ensure that the end-user is able to use a tractor made by a particular manufacturer in conjunction with multiple implements made by same or different manufacturers.

13.3 COMMONLY USED SYSTEMS

13.3.1 YIELD MAPPING

Yield mapping systems refer to the process of collecting geo-referenced data on crop yield and characteristics, such as moisture content, while the crop is being harvested.

Various methods, using a range of sensors, have been developed for mapping crop yields.⁴⁶

⁴⁵ <http://www.cema-agri.org/page/connected-agricultural-machines>

⁴⁶ <https://cropwatch.unl.edu/ssm/mapping>

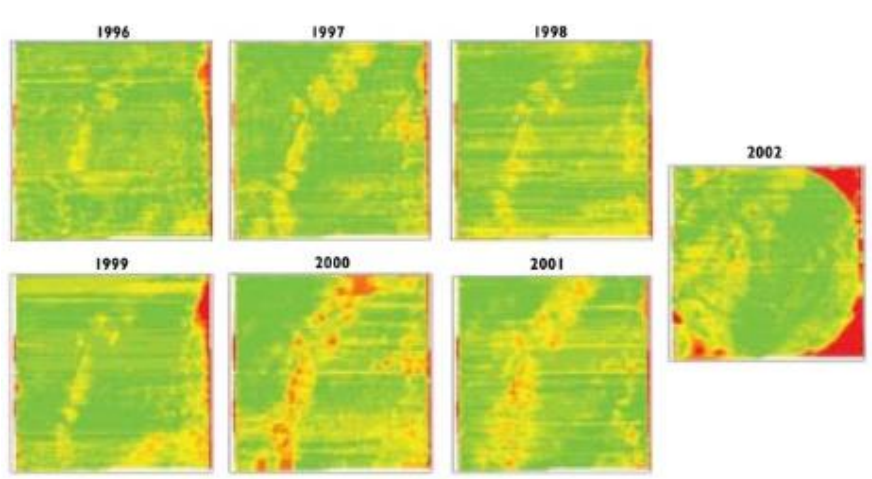

Figure 82: Yield Mapping (Source: <https://cropwatch.unl.edu/ssm/mapping>)

Yield mapping has now become important in precision farming as it is considered to be the starting point for its implementation.⁴⁷

By adopting the technology of yield mapping, and by producing actual yield maps, farm managers are able to use the additional information in a passive way by revealing spatial variations, but also in an active way as a support tool for future management decisions, for example:

- **long term decisions** - considering strategies such as crop rotation and temporal yield stability
- **intermediate decisions** - concerned with the next growing season, variety selections, fertilizer and pesticides applications
- **short-term decisions** - considering actual field or plant conditions during the growing season.

Yield maps can be used for a variety of reasons, however all uses require quality yield data. Some of the uses of yield data are as follows⁴⁸:

- defining consistent management zones using multiple years of normalised yield data
- creating gross and net profit maps to learn how to fine tune inputs to maximise profitability in all areas of the field
- identifying yield limiting factors to assess how much loss these cause – justifying the elimination or reduction of the effect of these factors
- calculating nutrients removed from the soil, and thus the amount that needs to be replaced in these areas.
 - This is particularly useful for base fertiliser, for comparisons, and for on-farm trials of different inputs, rates or management systems to see if their effects result in a yield effect.
- mapping costs vs. additional income from different trials across a field.
 - Other costs can also be compared and mapped depending on farm systems parameters, such as fuel performance and work rates.

The basic components of a grain **yield mapping** system include⁴⁹:

⁴⁷ <http://www.awgfarms.com/Mapping.PDF>

⁴⁸ <http://www.agrioptics.co.nz/wp-content/uploads/2013/03/Agri-Optics-4.pdf>

⁴⁹ <https://cropwatch.unl.edu/ssm/mapping>

- grain flow sensors - to determine the grain volume harvested
- grain moisture sensors – to compensate for grain moisture variability
- clean grain elevator speed sensors - used by some mapping systems to improve the accuracy of grain flow measurements
- GPS antenna – to receive satellite signals
- yield monitor displays (with GPS receiver) –to show georeference and recorded data
- header position sensors - distinguish various measurements logged during turns
- travel speed sensors - determines the distance a combine travels during a specific logging interval.
 - Travel speed is sometimes measured with a GPS receiver or a radar or ultrasonic sensor.

Each sensor must be properly calibrated according to the operator's manual.

Calibration converts the sensor's signal to physical parameters for display and/or recording. A proprietary binary log file may be created during harvest to record the output of all sensors as a function of time. This file can eventually be converted to a text format, or displayed as a map, using appropriate yield monitor software – as generally supplied by the vendor.

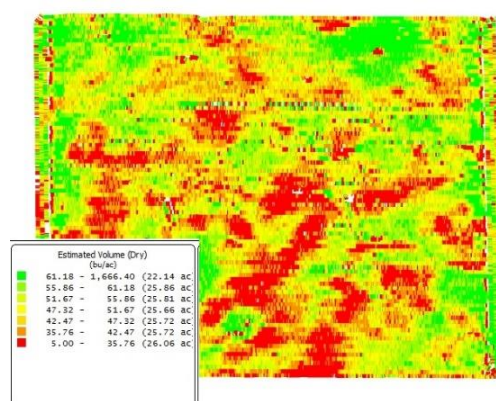

Figure 83: Grain yield map (Source : https://commons.wikimedia.org/wiki/File:Soybean_Grain_Yield_Map.jpg)

BENEFITS

An essential part of precision farming is **yield mapping**, where data can be recorded automatically during harvesting. Yield monitoring and mapping offers many other on-farm and off-farm benefits:⁵⁰

- **On-farm:** benefits include real-time information gathering during harvest, easier on-farm testing, improved variable rate management, evaluation of whole-field improvements, and the creation of historical spatial databases.
- **Off-farm:** benefits include more equitable property owner negotiations, crop documentation for identity preserved marketing, 'trace back' records for food safety, and the documentation of environmental compliance.

13.3.2 VARIABLE RATE TECHNOLOGY

Variable rate technology (VRT) is one of the crucial methods used in precision agriculture. There are three basic approaches to using variable rate technologies: (i) map-based, (ii) sensor-based, and (iii) manual. The adoption of variable rate technology is currently estimated at 15% of farms in North America where as in Europe is 13% to 16%.⁵¹ It is expected is expected to continue to grow rapidly over the next five years.

⁵⁰ <http://www.awgfarms.com/Mapping.PDF>

⁵¹ DEFRA- Department for Environment, Food and Rural Affairs, London,

Definition

Variable rate technology (VRT) – VRT refers to any technology that enables the variable application of inputs and allows farmers to control the amount of inputs they apply in a specific location.

13.4 AGROTECHNICAL OPERATIONS**13.4.1 SOIL PROCESSING**

Before a farmer embarks on growing crops, his/her first step is that of **soil preparation**.

A firm and weed-free seedbed is essential to promote an even and rapid germination, and hence the emergence of the crop. Turning the soil and loosening it are the key features of **tilling** (or ploughing).

Tilling creates optimal soil by:

- Mechanically destroying weeds that compete for water, nutrients and sunlight.



Figure 84: Source: <http://www.cema-agri.org/page/1-precision-soil-preparation>

- Incorporating organic material - residues left over from the previous crops are incorporated in the soil and decomposed.



Figure 85: Source: <http://www.cema-agri.org/page/1-precision-soil-preparation>

- Loosening the soil. Loosened soil allows the roots to penetrate deep into the soil and to breathe easily. It also supports the growth of earthworms and microbes.



Figure 86: Source: <http://www.cema-agri.org/page/1-precision-soil-preparation>

Soil preparation represent a major energy-consuming activity in agriculture.

It uses a significant amount of fuel and time, it risks soil erosion, and is highly dependent on the location of a field. These are elements that must be minimized through improving the accuracy, efficiency and sustainability of the precision farming equipment.⁵²

Technology can help in achieving the improvements required. **High precision positioning systems** (for example, **GPS**) can be used for accurate and repeatable driving within a field, and they can aid the navigation and positioning capability in any location, and at any time in all conditions. Using positioning systems, activities in the field – such as driving - can be recorded by using geographic coordinates (latitude and longitude) with a 2cm accuracy. This information can then be re-used for repeating subsequent driving activities in the field. There are various systems that implement this.

- **Automated steering systems** can accurately repeat specific driving tasks like auto-steering, overhead turning, following field edges and overlapping of rows. These technologies reduce human error and are effective for many site management operation. Automated steering systems take full control of the steering wheel allowing the driver to take his/her hands off the wheel during trips down the row, freeing them to keep an eye on planters, sprayers or other equipment.
- **Assisted steering systems** show drivers the driving paths to follow in the field, guided by satellite navigation systems such as **GPS**. This allows for more accurate driving though the farmer still needs to be steering the wheel.
- **Intelligent guidance systems** can provide different steering patterns (guidance patterns) depending on the shape of the field and can be used in combination with the systems above.⁵³

13.4.2 HARVESTING

The ingredients for successful **harvesting** are speed, accuracy and timing.

For the farmer, **harvesting** is a critical point in the year. However most tasks, once considered the most laborious and burdensome activities of the entire growing season, are now undertaken by some very sophisticated farm machines. These include:

⁵² <http://www.cema-agri.org/page/1-precision-soil-preparation>

⁵³ <http://cema-agri.org/page/precision-farming-key-technologies-concepts>

- **The combine harvester ('combine').** These combine three separate harvesting operations into one single process, i.e. the processes of:
 - reaping
 - threshing
 - winnowing.

Excess straw is either chopped and spread on the field or - using automated balers - baled to provide feed and bedding for livestock. Combines are used to harvest crops such as *wheat, oats, rye, barley, corn, soybeans and linseed*.

- **Forage harvesters ('foragers')** for feed production. Foragers chop grass, corn or other plant into small pieces, which are then compacted together in a storage silo for fermentation to feed livestock.
- **Specialist harvesters.** These are tailor-made machines developed for the automated harvesting of other fruits and crops, such as *potatoes, carrots, sugar beet, grapes, cotton or apples*. A key challenge for these machines is to ensure perfect extraction while maintaining the physical integrity of the crop.⁵⁴

With respect to harvesting, there have been many improvements in the detection of moisture, automatic cruising, and automatic adjustments depending on the crop volume.

Multiple sensors are used - for identifying yield changes, slope changes, even distributions of grain flow inside sieve elements, altering fan speeds and sieve position to reduce grain loss, monitoring key components for a safe working environment, proper engine cooling and reducing fuel costs.

In addition, there are many directly mounted yield monitoring systems commercially available. For example, a combination of *moisture sensor, mass flow sensor* and *grain yield monitoring* software gives farmers the opportunity to instantly see yields across the field, observe how field conditions affect the yield, create and view yield maps, and incorporate data that helps decision support systems.

13.4.3 SOWING

Seeding (or sowing) is a critical step in crop growing. For a successful seeding process, two challenges need to be overcome:

- **Correct depth.** If sown too deep into the soil, roots will not be able to breathe. If sown on the surface, birds may damage the seeds. Due to changing soil types, residue cover and moisture variation, avoiding excessive soil compaction can be a very challenging factor to manage throughout the entire planting process.

In addition, excessive soil compaction can cost a farmer valuable harvest time as lodging, root development, varying plant emergence, lack of soil moisture and other problems can result from improper or inconsistent planting depth. Commercially available controllers are available to help, and can be directly mounted on the planter to correct for the seeding depth using hydraulic force systems.

- **Proper distance.** If plants are overcrowded, they will not get enough water, nutrients and sunlight, resulting in yield loss. On the other hand, if plants are planted too far from each other, valuable land is left unused.

Modern precision seeding equipment can be used to place the seeds uniformly at proper distances and depths for optimal access to moisture and sunlight. The resulting fast, but uniform germination, ensures that the crop is best placed to compete with weeds. Uniformity promotes an even maturity of plant growth across the whole field, which makes for easier harvesting and greater yields.

Seeding systems can be combined with **geomapping** (maps showing soil density, quality, etc.), and combined with the **high precision positioning** systems that are implemented in many tractors and with

⁵⁴ <http://www.cema-agri.org/page/4-precision-harvesting>

variable rate technology (VRT) to provide data to help with reducing seed cost. These help to ensure that:

- **More seeds** are planted in soil with favourable growing conditions
- **Less seeds** are planted in poor soils, which avoids loss of crop production or void areas

Precision technologies are a significant help to farmers in continually refining the seeding process, and in achieving higher yields with less seed.⁵⁵



Figure 87: Source: <http://ausplow.com.au/>

13.4.4 SPRAYING, FERTILIZATION, IRRIGATION

While they are in their growth, phase plants need the right amount of nutrients, water and proper protection from pests and disease.

Precision farming solutions are helping the farmers to increase the yield, but with fewer costs. The key processes here are:

- **Fertilisation** - to ensure that plants get right amount of nutrients
- **Crop Protection / Spraying** - to give adequate protection from pests and diseases to plants
- **Irrigation** - to provide the right amounts of water to the plants

Precision Fertilising makes use of:

- **Crop sensors** to obtain general information on crop health
- **Automatic wind controls** to adjust the sprayer dependent on the wind speed and direction
- **Optimised boundary spreading** to correct spread of fertilizers at the boundaries of a field

These sensors eliminate the risk of over and under-fertilisation, which is important as growth and yield can fluctuate greatly within a field. They also help to produce a uniform growth rate.

⁵⁵ <http://www.cema-agri.org/page/2-precision-seeding>



Figure 88: Source: <http://www.cema-agri.org/page/3-precision-crop-management>

Precision Spraying makes use of:

- **Satellite steering systems (GPS)** to help to reduce spraying by avoiding overlap of areas.
- **Variable rate application (VRA)** to control variable application of sprays based on data collected by sensor maps and **GPS**.

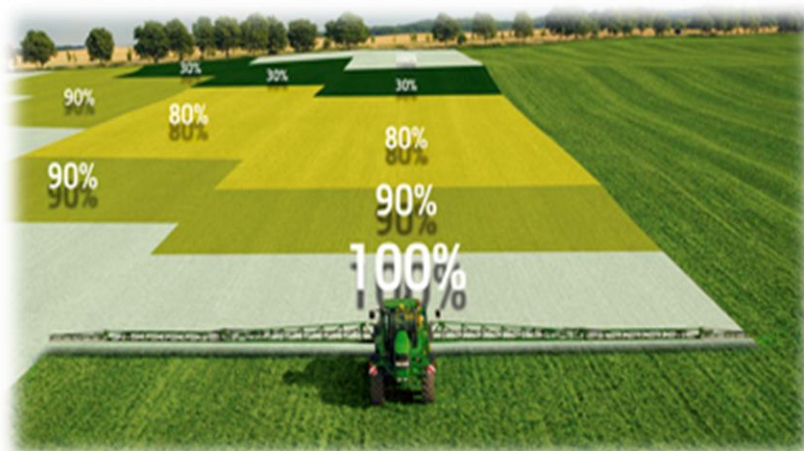

Figure 89: Source: <http://www.cema-agri.org/page/3-precision-crop-management>

Precision Irrigation makes use of:

- **Subsurface Drip Irrigation (SDI)** which provides the most effective management control of water and nutrients delivered directly to the plant roots, at the precise time and in the precise quantity needed.



Figure 90: Source: <http://www.cema-agri.org/page/3-precision-crop-management>

14 DIGITAL FARM MANAGEMENT SYSTEMS

In this section you will learn about:

- *how to define data integration*
- *data intermediaries and challenges of data integration*
- *commonly used digital systems in agricultural sector.*

14.1 DATA INTEGRATION

The agriculture sector has its own data complexities and challenges, some of which may be specific to the sector.

For example, an individual farm may collect data on a wide range of fronts - plant production results, livestock production, farm food production, etc. There is therefore an essential need for **data integration**.

There are two key considerations for data integration:

- combining results from all fields of interest
- timing – obtaining results in acceptable timeframes.

Both of these should be targets for data integration, or 'data warehousing' - technologies that are used to aggregate structured data from one or more sources so that it can be compared and analysed for greater business intelligence. This is at the heart of digital farm management systems.

Similarly, data that is needed for studying agricultural systems can spread across several areas (domains), including ecology, crop science, agronomy, meteorology, economy, policy and demographics. Any modelling framework that aims to integrate crop biophysical models and agro-economic models, at different scales of time and space, needs to offer processes and tools for the seamless and sound management of data. Data integration permeates every aspect of farm management and studies.

Data integration presents its own problems, including ensuring that data can be accessed by people and systems that need to use it, data from different sources need to be homogenized (combined from disparate sources into meaningful and valuable information), documented and properly annotated before it can be used to effect. Once these issues had been resolved, then higher level considerations – such as interpreting the rich meta-data required for simulation results – must be taken into account so that the data can be unambiguously interpreted to build knowledge bases that can be tapped to provide some degree of quality control.⁵⁶

To improve the use of agricultural data for farming in the 21st century there are projects to create integrated databases for the storage of farm data across different areas of agriculture. To achieve **standardization** in agriculture, there is a need to create such systems based on common data structures, though this process is much slower and more complicated than in other areas of business or industry due to the specific circumstances seen in the agro-sector.⁵⁷

There are many agricultural databases available, but the scale and technological differences make them difficult to use coherently. For example, the Food and Agriculture Organization (FAO) of the United Nations has approximately 200 systems supplying information for access on the World Wide Web. These data sources need to share and exchange data between each other, and around the community, coherently but the technological history of these various systems means that there are incompatibilities between the databases. Some differences are technological, others are structural or to do with language.

Technology must be adapted to support interoperability of data sources, and potentially the management of multilingual variants, but without changing the underlying database structures.

⁵⁶https://www.researchgate.net/publication/220792646_Ontology_for_Seamless_Integration_of_Agricultural_Data_and_Models

⁵⁷ http://www.agris.cz/Content/files/main_files/73/151008/mareth1.pdf

Currently, there is no standard way of managing language variants of data structures, which generates inconsistencies between applications.

The 'solution' to some of these issues is found in the many web developments - technologies that support problems in e-business, easing the ability to both represent and describe data structures in ways that are relatively easy to implement and to maintain.

Importantly these approaches can be implemented on multiple public and vendor platforms, with minimal effort and disruption to any existing systems. The FAO approach is detailed here - <http://www.fao.org/docrep/008/af229e/af229e05.htm>.

14.1.1 DATA INTERMEDIARIES

Any improvements in the digital farming industry must focus on the real needs of the farmers, i.e. to:

- identify and understand the essential data needs
- understand standards and formats used
- implement workable licensing schemes that enable processes to work
- understand data collection practices, including measurements and biases
- win the trust of data providers and users.

There is a critical role to be played by data intermediaries who fulfil the roles of data importers – collating and preparing external data for use by farmers. There are a huge range of data sources, and the vast quantity of raw collected has to be transformed manageable information capable of supporting, and being used by, decision-making tools. These providers, enablers and handlers of data-driven services for farmers are critical actors within agro-food data systems.

There are two types of intermediary:

- Providers and handlers of data-driven services, and directly involved with collating and managing the data itself. These intermediaries work both with external data sources on the farm and with data sharing with other actors.
- Extension agents and commercial advisers who take responsibilities for the interpretation of the data set (usually at the point of information collection), and for transforming it into usable knowledge.

Any data intermediary work has to be done within the restrictions imposed by any data ownership issues. For example, it may be necessary to anonymize certain data, or to transform the data from one standard or formats to another to use to make data reusable. Data intermediaries may also be involved in the export of farm data to other segments of the value chain, and may be required to adapt or transform it to make it fully re-useable along the value chain.

At the level of precision agriculture, data transfers are dependent on the automated capture, transfer and management of data - from crop planning to farm management, to inventory and supply chain tracking. As more and more farm activities rely on the capture and analysis of multiple data sets coming from multiple sources, data integration represents a key issue for the future of digital farming.

14.1.2 FARM SOFTWARE AND SYSTEMS

Dependent of the farm size and the input data that is collected, farm software systems can support the unique circumstances of, and individual and custom decision-making operations, on a farm.

Definition

Software, and software systems, for farms are computer programs developed to compute the optimum operational requirements for a known farm size and its set of farm machinery - consisting of tractors and tractor-drawn implements.

These systems are only as good as their underlying data, which might include the costs of tractor and implements, fuel and oil prices, labour charges, farm size, yield of crop and value of crop, etc. - in addition to the various 'constants' that might be used in the programs.

Farm management information systems (FMIS) for precision agriculture have certain additional requirements over traditional **FMIS**, which makes the implementation of these systems technically more complicated in a number of ways. The basic components of a farm management information system include a computer, software, a controller and a differential global positioning system (**DGPS**).

14.2 HANDHELDS, TABLETS AND SMARTPHONES

Smartphones are one of the most used devices in agriculture.

Whether connected through wireless or using Internet data through your mobile provider (GSM networks), these devices can connect with websites, applications and other information services needed in today's precision farming.

Applications are generally third-party software services for smartphones and tablets that perform specific functionality, either online or offline.



Figure 91: Source:<http://imotforum.com/2018/01/agri-mobile-apps-india/>

Agricultural applications (apps) fall into a small number of basic functional categories:⁵⁸

1. **Farm Management/Data Collection Apps.** These are applications used for farm planning, generally allowing for the easy tracking of data such as sensors inputs, soil tests, stocking rates, pest/disease issues and treatment, machinery procedures, staff management. etc.

⁵⁸<https://grdc.com.au/resources-and-publications/grdc-update-papers/tab-content/grdc-update-papers/2012/03/emerging-technologies-in-agriculture-smartphones-tablets-apps-and-social-media>

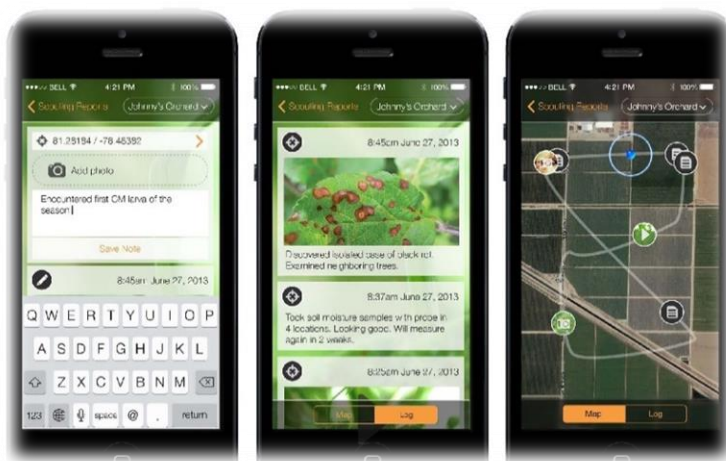

Figure 92: Source: https://www.agriculture.com/machinery/precision-agriculture/technology-lets-you-document-share_234-ar42503

2. **Calculator Apps:** These are apps that support field calculations in the paddock. Examples of these apps can include calculators to optimize how much spray is needed to treat a particular area, to calculate fertiliser quantities and costs, to advise on seeding rates, and to estimate yields and lambing statistics.



Figure 93: Source: <https://appagg.com/android/business/ju-agri-17853133.html>

3. **Information/Resource Apps:** These are apps that connect to valuable information sources, allowing farmers to make informed decisions in the paddock. There are a huge variety of apps available covering a large array of information for pest, disease and weed identification, for marketing, and information on the very many products used in agriculture.
4. **News Apps:** These are simple news 'aggregators' that collate and deliver specific industry information and news.
5. **Weather Apps:** Perhaps one of the most widely used app, weather apps provide access to frequently updated weather forecasts.
6. **Enabling Apps:** Simple apps that help with everyday tasks. Examples of this type of application are apps providing digital mapping, simple note-taking and calendaring (setting dates and reminders), livestock counters, cameras, and document storage.

Smartphones have become an essential tool for farmers in their everyday work, and their use is being seen in almost all operations, such as:

- navigating fields
- the identification of weeds, diseases, and pests
- calculating fertilizer and chemical blends
- checking rainfall measurements
- meeting with agricultural advisors
- tracking grain harvests, etc.



Figure 94:

Source: <https://www.konstantinfo.com/blog/wpcontent/themes/konstantinfo/imageC.php?image=/2016/03/Agriculture-Apps.jpg>

14.3 ENTERPRISE INFORMATION SYSTEMS

Enterprise information systems (**EIS**) support service improvements and operations, deal with large volumes of data, and support processes and decision-making in large and possibly complex organizations or enterprises. When adopted, they tend to be used by all parts, and all levels, of an enterprise.

Definition

An enterprise information system (EIS) is any kind of information system which improves the functions of an enterprise business processes by integration.

Two key components include:

- **Enterprise resource planning (ERP)**
ERP software integrates all facets of an operation, including product planning, development, manufacturing, sales and marketing.

Definition

Enterprise resource planning (ERP) is business process management software that allows an organization to use a system of integrated applications to manage the business and automate many back office functions related to technology, services and human resources.

A business can use **ERP** software to manage back-office activities and tasks including:

- distribution process and supply chain management
- services knowledge base to configure, prices, improve accuracy of financial data
- facilitating better project planning
- automating employee life-cycle, managing human resources and payroll.
- standardizing critical business procedures, reducing redundant tasks
- assessing business needs

- accounting and financial applications, lower purchasing costs

Some of the most common **ERP** modules include those for product planning, material purchasing, inventory control, distribution, accounting, marketing, finance and HR.

The main task of an **enterprise resource planning system** is to create a single central repository for data created and shared by all the various **ERP** facets, to enhance and improve the flow of data across the enterprise.⁵⁹

- **Decision Support System (DSS)**

DSS are used for planning and analysing activities, and for aiding decision-making.

Definition

A **Decision Support System (DSS)** is defined as an information system application that assists the managers in decision making. They generally include: a database, a model base, and a user interface.

By providing an interactive user interface to interact with the underlying data, various types of information of managerial end users can be assisted in decision-making processes. **DSS** help managers to manage, and even solve, the various semi-structured and unstructured problems they typically face in their professional life.

An agricultural information system (IS and DSS) can be defined as a system in which agricultural information is generated, transformed, transferred, consolidated, received and fed back in such a manner that these processes function synergistically to underpin knowledge utilization by agricultural producers (Roling, 1988).

14.4 TRACEABILITY SYSTEMS

The agriculture community - the key source of our food - has a critical role to play in maintaining the health of people and the environment, and it also plays a key role in reducing burgeoning health-care costs.

Both human health and the agriculture and food industry stand to benefit greatly from an integrated food strategy, which is largely enabled through effective traceability (Sparling, 2010).⁶⁰

The **International Organization for Standardization (ISO)** and **Codex Alimentarius Commission (CAC)** defines traceability as:

- "ability to follow the movement of a feed or food through specified stage(s) of production, processing and distribution"

Globalization has massively increased the cross-national trade of food products, but with this increase comes a corresponding potential for an increase in the number of food-borne illnesses.

Outbreaks of botulism, salmonellosis, etc. cause various food poisoning outbreaks, and a number of deaths, every year. Food safety and public health concerns have therefore forced food producers and processors to adopt preventive measures for product identification and traceability.

Traceability is the ability to track and follow the movement of products throughout the food chain, i.e. all stages and operations involved in the production, processing, distribution, storage and handling of a food and its ingredients - from production to consumption.

⁵⁹ <https://www.linkedin.com/pulse/enterprise-information-systemeis-resource-planning-erp-why-ezenwa/>

⁶⁰ <https://vcm-international.com/wp-content/uploads/2013/08/Traceability-Is-Free.pdf>

Food safety and quality management systems have been developed to establish and maintain a traceability system, enabling the identification of products to batches of raw materials, processing and delivery records. Traceability is of such importance that it has become a regulatory requirement.

The International Organization for Standardization (ISO) published ISO 22005:2007, an international standard that sets out the principles, and specifies the basic requirements, for the design and implementation of a traceability system in the agro-food and feeds industry. This standard demands that organizations operating at any step of the food chain be able to:

- trace the flow of materials - feeds, foods, ingredients and packaging
- identify necessary documentation and tracking for each stage of production
- ensure adequate coordination between the different actors involved
- improve communication among the involved parties, and most importantly
- improve the appropriate use and reliability of information, effectiveness and productivity of the organization.

The main processes of **traceability systems** are:

- identification of units / batches of all ingredients and products
- registration of information on when and where units / batches are moved or transformed
- a system linking these data and transferring all relevant traceability information with the product to the next stage or processing step.

In order to implement a traceability system within a supply chain there is a need for all parties involved to adopt uniform industry requirements regarding the identification of products, and to link the physical flow of the products with transparency and continuity across the supply chain.

There are two dimensions to traceability.

14.4.1 EXTERNAL TRACEABILITY

If all traceable items are uniquely identified, and information is shared between all affected distribution channel participants, then external traceability is achievable.

The identification of products for the purpose of traceability may include assignment of a **Unique product identification** number and a **Batch/lot** number.

To maintain external traceability, traceable item identification numbers must be communicated to distribution channel participants on product labels and related paper or electronic business documents. This links the physical products with the information requirements necessary for traceability.

External traceability allows both tracing back (supplier traceability) and tracking forward (client traceability).

14.4.2 INTERNAL TRACEABILITY

Internal traceability implies that processes must be maintained within an enterprise in such a way as to link identities of raw materials to those of the finished goods.

When one material is combined with others, and processed, reconfigured, or repacked, the new product must have its own **Unique Product Identifier**. The linkage must be maintained between this new product and its original material inputs in order to maintain traceability.

The implementation of effective traceability systems improves the potential of implementing verifiable safety and quality compliance programs. The resulting visibility of relevant information enables agro-food businesses to better manage risks, and to allow for rapid reaction to any emergencies, recalls, and withdrawals.

Effective **traceability systems** significantly reduce response times when an animal or a plant disease outbreak occurs, by providing rapid access to relevant and reliable information that helps to determine the source and location of implicated products. Thus, information (about animal and plant health,

country of origin etc.) collated at any, or every, point in the chain - from producer to consumer - has become a crucial requirement.

14.4.3 RISK MANAGEMENT

Traceability in the EU is mainly driven by risk assessment, risk management and risk information.

The EU food laws aim to manage and reduce risk through the application of **HACCP (Hazard Analysis Critical Control Point)**-based programs and traceability working together to identify and control risks.

The **Codex Alimentarius Commission (CAC)** was established to harness its expertise and influence so that people can trust that the food they buy and eat is safe and honest. The CAC gives precise principles for using **traceability** as a tool:

- **Inspection** - the examination of food or systems for control of food, raw materials, processing and distribution, including in-process and finished product testing, in order to verify that they conform to requirements.
- **Certification** - the procedure by which official certification bodies and officially recognized bodies provide written or equivalent assurance that foods or food control systems conform to requirements. Certification of food may be, as appropriate, based on a range of inspection activities which may include continuous on-line inspection, auditing of quality assurance systems, and examination of finished products.
- **Equivalence** - the capability of different inspection and certification systems to meet the same objectives.
- **Traceability/product tracing** - the ability to follow the movement of a food through specified stage(s) of production, processing and distribution.⁶¹

The long-standing issue of food safety has been the leading reason for adopting these kind of regulations. Indeed, both governments and buyers have reason to take such measures seriously in the face of potential crises that might arise, such as outbreaks of avian flu or BSE. **Traceability systems** re-assure customers by providing reliable information and guarantees about product authenticity.

While this may be the case in places such as Europe and North America, many developing countries face significant obstacles in achieving requisite traceability standards. Many lack the necessary information and communications infrastructures to implement effective traceability systems, which are often also perceived as very costly.

⁶¹ CAC/GL 60-2006 Principles for Traceability / Product Tracing as a Tool Within a Food Inspection and Certification System www.codexalimentarius.net/input/download/standards/.../CXG_060e.pdf

14.5 MODULE 3 GLOSSARY

A

AUTOMATION - use of various control systems for operating equipment such as machinery, processes in factories, boilers and heat treating ovens, switching on telephone networks, steering and stabilization of ships, aircraft and other applications and vehicles with minimal or reduced human intervention

AGGREGATE - a material or structure formed from a mass of fragments or particles loosely compacted together.

AERIAL VEHICLE - an aircraft piloted by remote control or on board computers

AUGMENTED REALITY - a technology that superimposes a computer-generated image on a user's view of the real world, thus providing a composite view.

ARTIFICIAL INTELLIGENCE - the theory and development of computer systems able to perform tasks normally requiring human intelligence, such as visual perception, speech recognition, decision-making, and translation between languages.

AGRICULTURE 4.0 – stands for the integrated internal and external networking of farming operations.

B

BENCHMARKING - comparing ones business processes and performance metrics to industry bests and best practices from other companies.

BIG DATA - extremely large data sets that may be analysed computationally to reveal patterns, trends, and associations, especially relating to human behaviour and interactions.

C

CONNECTIVITY - a generic term for connecting devices to each other in order to transfer data back and forth. It often refers to network connections, which embraces bridges, routers, switches and gateways as well as backbone networks. It may also refer to connecting a home or office to the Internet or connecting a digital camera to a computer or printer.

CAPACITANCE - the ability of a system to store an electric charge.

CROP YIELD - measure of the yield of a crop per unit area of land cultivation, and the seed generation of the plant itself.

CALIBRATION - is the comparison of measurement values delivered by a device under test with those of a calibration standard of known accuracy.

D

DATA INTEGRATION - is the combination of technical and business processes used to combine data from disparate sources into meaningful and valuable information.

DATA STANDARDIZATION - is the process by which similar data received in various formats is transformed to a common format that enhances the comparison process.

DRY BULK DENSITY - the weight of soil in a given volume.

DECISION SUPPORT SYSTEM (DSS) - is defined as an information system application that assists the managers in decision making. They generally include: a database, a model base, and a user interface. A set of related computer programs and the data required to assist with analysis and decision-making within an organization.

DATABASE MANAGEMENT SYSTEM (DBMS) - system software for creating and managing databases.

DATA - the quantities, characters, or symbols on which operations are performed by a computer, which may be stored and transmitted in the form of electrical signals and recorded on magnetic, optical, or mechanical recording media.

DIGITAL FARMING - applying precision location methods and decision quality agronomic information to illuminate, predict, and affect the continuum of cultivation issues across the farm.

3D MAPPING - projection technology used to turn objects, often irregularly shaped, into a display surface for video projection.

E

ESA - European Space Agency

EUMETSAT - European Organisation for the Exploitation of Meteorological Satellites

EEA - European Environment Agency

ECMWF - European Centre for Medium-Range Weather Forecasts

ENTERPRISE RESOURCE PLANNING (ERP) - business process management software that allows an organization to use a system of integrated applications to manage the business and automate many back office functions related to technology, services and human resources.

EVAPOTRANSPIRATION (ET) - is the combination of evaporation from the soil surface and transpiration by plant materials.

ENTERPRISE INFORMATION SYSTEM (EIS) - is any kind of information system which improves the functions of an enterprise business processes by integration.

F

FARM MANAGEMENT INFORMATION SYSTEM (FMIS) - is a management information system designed to assist agricultural farmers to perform various tasks ranging from operational planning, implementation and documentation for assessment of performed field work.

FREQUENCY-DOMAIN REFLECTOMETRY (FDR) – method for measuring soil moisture content

G

GRID PATTERN - a network of intersecting parallel lines

GEOSTATISTICS - class of statistics used to analyse and predict the values associated with spatial or spatiotemporal phenomena.

GPS (GLOBAL POSITIONING SYSTEM) - is a satellite navigation system used to determine the ground position of an object.

GIS (GEOGRAPHICAL INFORMATION SYSTEMS) - system designed to capture, store, manipulate, analyse, manage, and present spatial or geographic data.

H

HAZARD ANALYSIS AND CRITICAL CONTROL POINTS (HACCP) - is a systematic preventive approach to food safety from biological, chemical, and physical hazards in production processes that can cause the finished product to be unsafe and designs measures to reduce these risks to a safe level

HARDWARE - tools, machinery, and other durable equipment.

HARVEST - process of gathering a ripe crop from the fields

I

INTERNET OF THINGS (IoT)- The Internet of Things is the network of physical devices, vehicles, home appliances, and other items embedded with electronics, software, sensors, actuators, and connectivity which enables these things to connect, collect and exchange data.

IRRIGATION - application of controlled amounts of water to plants at needed intervals

IoT 'GATEWAY'- a device or software programme that serves as the connection point between the 'cloud' and controllers, sensors and intelligent devices

INFORMATION AND COMMUNICATION TECHNOLOGY (ICT) - refers to the convergence of audio-visual and telephone networks with computer networks through a single cabling or link system

ISOBUS STANDARD - software stack that supports serial data transfer for in-vehicle communication between agricultural tractors and implements.

L

LEGACY TECHNOLOGY - is an old technology, that is relating to, or being a previous or outdated technology yet still in use.

LANDSAT - series of Earth-observing satellites

M

MICROELECTROMECHANICAL SYSTEM (MEMS) - technology of microscopic devices, particularly those with moving parts.

MOBILE APPS - are software programs designed to run on smartphones, tablets and other devices.

O

ORTHOMOSAIC MAPS - aerial photograph geometrically corrected ("orthorectified")

ORTHOMOSAIC MAP – is the grouping of many overlapping images of a defined area, processed to create a new, larger mosaic of great detail and in true scale.

OPEN SOURCE DATA SHARING - means that the data is available for everyone to download, analyse, update, and contribute to.

ORTHOGRAPHIC IMAGES - are photographic images constructed from vertical or near vertical aerial photographs.

ORTHO PHOTO (ORTHO IMAGE) - is an image which has been 'corrected' for the geometric distortions (different projection, lens/sensor distortion, relief) so that it can be used as a map.

P

PLANT NUTRITION - is the study of the chemical elements and compounds necessary for plant growth, plant metabolism and their external supply.

PHYTOPATHOLOGY - The scientific study of plant diseases and their causes, processes, and effects.

PHENOTYPING - the observable physical or biochemical characteristics of a plant, including both its genetic makeup and its environmental influences.

POPULATION - can be defined as all items and characteristics being studied. Gathering all information about every item would be time consuming, costly and probably impossible. By sampling a subset of a population, inferences can be made about the population as a whole.

PRECISE LIVESTOCK FARMING (PFL) - use of advanced technologies to optimize the contribution of each animal.

PRECISION AGRICULTURE - is a farming management concept based on observing, measuring and responding to inter and intra-field variability in crops.

PENETROMETER - an instrument for determining the consistency or hardness of a substance by measuring the depth or rate of penetration of a rod or needle driven into it by a known force.

R

RURAL AREAS - geographic area that is located outside towns and cities.

RTK-GPS - Real-time kinematic (RTK) positioning is a satellite navigation technique used to enhance the precision of position data derived from satellite-based positioning systems (global navigation satellite systems, GNSS) such as GPS, GLONASS, Galileo, and BeiDou.

REMOTE SENSING (RS) - acquisition of information about an object or phenomenon without making physical contact with the object and thus in contrast to on-site observation.

RGB SPECTRUM - spectrum in which red, green and blue light are added together in various ways to reproduce a broad array of colours

REMOTE SENSING - is the acquisition of information about an object or phenomenon without making physical contact with the object and thus in contrast to on-site observation

S

SUBSURFACE DRIP IRRIGATION (SDI) - is the irrigation of crops through buried plastic tubes containing embedded emitters located at regular spacings.

SMART FARMING - is a capital-intensive and hi-tech system of growing food cleanly and sustainable for the masses.

SMARTPHONE - a mobile phone that performs many of the functions of a computer, typically having a touchscreen interface, Internet access, and an operating system capable of running downloaded apps.

SPECTRORADIOMETER - device designed to measure the spectral power distribution of a source.

SAMPLING - taking a representative portion of a material or product to test

SOFTWARE - the programs and other operating information used by a computer.

SENSORS - device that detects and responds to some type of input from the physical environment. The specific input could be light, heat, motion, moisture, pressure, or any one of a great number of other environmental phenomena.

SOIL FERTILITY - ability of a soil to sustain agricultural plant growth, i.e. to provide plant habitat and result in sustained and consistent yields of high quality.

SOIL - mixture of organic matter, minerals, gases, liquids, and organisms that together support life.

SPATIAL DATA - usually stored as coordinates and topology, and is data that can be mapped

SPECTRAL INDICES - combinations of spectral reflectance from two or more wavelengths that indicate the relative abundance of features of interest.

SOIL ZONING - formation of zones within one agricultural field based on the functions of the soil defined from the soil analysis and other methods

T

TRACEABILITY - ability to follow the movement of a feed or food through specified stage(s) of production, processing and distribution

TIME DOMAIN REFLECTOMETRY (TDR) - measurement technique that correlates the frequency-dependent electric and dielectric properties of materials

TIME DOMAIN TRANSMISSOMETRY (TDT) - analogous technique that measures the transmitted (rather than reflected) impulse.

U

UNIQUE PRODUCT IDENTIFIERS - define the product in the global marketplace. Common unique product identifiers include Global Trade Item Numbers (GTINs), Manufacturer Part Numbers (MPNs), and brand names.

UAV - an unmanned aerial vehicle (an aircraft piloted by remote control or on board computers)

V

VOLUMETRIC WATER CONTENT - represents the portion of the total volume of soil occupied by water.

VEGETATION INDICES - is a spectral transformation of two or more bands designed to enhance the contribution of vegetation properties and allow reliable spatial and temporal inter-comparisons of terrestrial photosynthetic activity and canopy structural variations

VARIABLE RATE TECHNOLOGY - any technology that enables producers to vary the rate of crop inputs.

Y

YIELD MAPPING - process of collecting georeferenced data on crop yield and characteristics, such as moisture content, while the crop is being harvested.

15 APPENDICES

In order to test, collect feedback and effect improvements to the courses two pilot implementations were organized in the target countries of Hungary (HU) and Macedonia (MK).

These teacher training pilots were implemented a:

- a short blended-learning offering, to introduce the concepts to participants and to offer guidance to the second phase ...
- which was delivered as online learning guided by tutors in each of the target countries.

The initial pilot was carried out in Hungary, followed shortly afterwards by a second in Macedonia. This phasing ensured that any early issues are identified and addressed early.

Teacher recruitment started with the implementation of the survey undertaken to:

- provide a state-of-art overview of European strategies for ICT skills in the agricultural sector
- look for particular European and national trends
- report in detail about the current situation in the two target countries
- invite teachers and advisors to participate in the course.

The pilots took place over an extended period, to take into account teacher workloads at various points in their semesters and delivered as three full courses forming a natural package. The pilot courses were delivered using a networked learning methodology, i.e. with tutors facilitating the online communications and collaborations of the participants

The pilots began with a contact day in both countries in order to provide the basic skills of working, navigating, and learning on the delivery platform, but also to learn about each other. They employed contemporary, innovative pedagogical methods - including project/based learning and the flipped classroom model - in order to provide an opportunity for the participants to try out the methods that they will learn about during the course.

Following this initial contact day study was conducted online with participants being guided by tutors.

The course closed with another contact day at which participants were given the opportunity to discuss any problems, to put questions to the tutors, and to debate possible sustainability plans for the future.

15.1 FEEDBACK FROM THE HUNGARIAN PILOT

After completing the three modules of the curriculum in each of the three target languages (EN, HU, MK) they were uploaded to the project's Moodle e-learning framework. An initial pilot training course was launched for Hungarian agricultural vocational schools. The "Teaching agricultural informatics in agricultural vocational training" course started with an information day in Gödöllő on 15 February 2019.

Applications for the Information Day was conducted via an online registration form. In total 46 teachers from many different parts of the country attended the information day event.

In addition to presenting the aims of the project and details of the planned training, a number of lectures were also given by expert practitioners in the field of agricultural informatics, including Agromechatronics, Farming 4.0, Data Collection in Precision Agriculture, and Precision Animal Husbandry.

For the first of the three project modules - Teaching in the 21st century in Agricultural Vocational Schools - lectures on web-based tools, the flipped classroom model, and a methodological renewal of 21st century education were presented.

Following this information day, a total of 63 teachers from 22 VET schools across the country applied for the pilot training course itself. See the following map for the distribution of these schools.

The pilot training was conducted wholly online with the learning activities being led by professional trainers / tutors. The training materials for the three pilot modules were covered according to the following schedule.

- Module 1. Teaching in the 21st century: 25 February- 10 March, 2 weeks
- Module 2. European Strategies & E-agriculture Initiatives: 11 March - 17 March, 1 week
- Module 3. Digital systems within Agriculture 4.0: 18 March- 26 April, 6 weeks

Each module included:

- an introductory video for the module
- a description of the learning aims of the module
- a learning guide
- a module assignment.

The final assignments were mostly taken from the practical exercises within the given topic.

On the online platform, the participants were able to communicate with each other and with the tutors, to exchange ideas or to potentially ask for help. Tutors also posed questions related to the topics within the modules to encourage active participation and to share in valuable experiences from the teachers' own practice.

In addition, and partly as an experiment, an online 'webinar' was held by one of the professional tutors - Zsófia Veres, an experienced agricultural engineer in environmental management - about AgLeader SMS, a user-friendly software application specifically used for precision agriculture. It was suitable for the teachers as it required only a basic knowledge of GIS principles.

In order to successfully complete their training, participants had to complete the following tasks (with the stated weightings).

- Show active collaboration on the online learning platform (10%)
- An assignment to be submitted at the end of Module 1 (20%)
- An assignment to be submitted at the end of Module 2 (20%)

- Module 3 – the Closing Assignment (50%)

The Closing Assignment for the overall course comprised:

1. Choosing an appropriate ICT tool and / or method from the first module
2. Developing one's own curriculum for teaching Module 2 or 3
3. Preparing a Lesson Plan / Teaching / reflection.

The training was successfully completed by 51 of the teachers, each of whom received:

- a certificate of 'Innovative Teacher, Creative Classroom', accredited within the Hungarian teacher in-service training program (30 credits)
- a certificate from the AgriTeach Consortium for the course: 'Teaching Agricultural Informatics in Agricultural Vocational Training'.

At the end of the course, participants evaluated the pilot training based on an online questionnaire. This evaluation included:

- To what extent was the information learned during the training novel and useful for you?
 - Extremely novel and useful - 48%
 - Very useful - 38%
- What was the quality of the training materials provided?
 - Very good - 71%
 - Good - 26%
- To what extent did the course support your professional development?
 - Extremely supportive - 49%
 - Very supportive - 33%
- How did you rate the course overall?
 - Very good - 56%
 - Good - 41 %

The closing event of the pilot training, including the certificate award ceremony, took place on June 13, 2019 in Makó, attended by most of the successfully completing vocational school teachers and by the partners of the Agritech 4.0 project.

The scale of the pilot training, coupled with the very high percentage of completing teachers, was deemed to be a very successful and beneficial experience for the partnership.

The training materials created in the project are openly available at this Moodle site – readily accessible after a minimal registration process:

<http://moodle.agriteach.hu/>

15.2 FEEDBACK FROM THE MACEDONIAN PILOT

Following the finalization of the English version of the online course, the course was translated into Macedonian. The Macedonian version of the course is based on the English course but with some minor modifications that relate to the specific agricultural profile of that country.

Starting from April 1st until May 6th, 20 teachers from seven VET schools in North Macedonia, enrolled in the pilot course.

The pilot began with a contact day in order to provide the teachers with the basic skills of working, navigating, and learning on the delivery platform, and also to learn about each other. For the first week - from April 1st to April 8th, the Module1 (*Teaching in the 21st Century*) pilot was run.

During the pilot of Module 1, the participants had the opportunity to introduce themselves via the Forum on the Moodle learning platform, and to discuss the challenges and assignments with their mentor, Mr. Ljupcho Toshev. Module 1 introduced and used contemporary, innovative pedagogical methods - including project/based learning and the flipped classroom model - thereby providing an opportunity for the participants to try out the methods that they learned about during the course.

After successfully implementing Module1, the implementation of the pilot phase of Module2 (*European Strategies and Initiatives for e-Agriculture*) started on April 10th. The goal of this second module was to inform teachers about the importance of a strategic approach to the development of e-agriculture in the EU, and to detail the main steps and components of the process, including standards and formats. The implementation of the pilot phase of Module2 ran until April 17th with Mr. Martin Micevski as the mentor.

Finally, from April 22nd until May 6th, the pilot phase of Module 3 (*Digital systems within Agriculture 4.0*) was implemented. The aim of the third module was to encourage a teaching approach fostering lifelong learning skills, promoting intellectual curiosity, and developing competencies in innovative agriculture technologies. In this module, teachers had the opportunity to learn about the technology used in digital farming, how ICT can improve the overall agricultural production, and to analyze and compare different approaches in agriculture using IoT technologies. Through the content of this module, the teachers were able to develop a greater understanding of the benefits, trends, methods and practices of different applicative solutions in Agriculture 4.0. The mentor for the Module 3 was Mr. Blagoja Mukanov.

Out of 20 participants, 16 teachers from six different VET schools successfully completed the course. In order to successfully complete the course, 80 points were required out of a total of 100 points. Participants in the course gained points by completing the assignments and quizzes in each of the three modules. All participants who successfully passed the course were given certificates by the Agriteach 4.0 consortium.

The general feedback from the participants, regarding the course was very positive. Some of the teachers had previous experience with Moodle and similar educational tools, while others used it for the first time.

The participants agreed that learning through Moodle and other similar learning management system stimulates even the least interested students. All participants also agreed that the online course had a significant impact in their professional development and after completing the course, they are ready to implement some of the new methodologies learned in Module 1.

The biggest limitation that the teachers faced was the unstable internet connection in some of the schools and the old, poorly maintained or inadequate computer systems in the schools.

The course concluded with another contact day during which participants were given the opportunity to discuss any problems, put questions to the tutors, and to debate possible sustainability plans for the future.

CONNECTING VET TEACHERS TO AGRICULTURE 4.0

The rapid evolution of technology – from vehicles, radio, television, mobile phones, to computers and ‘smart’ devices – has unquestionably led to advances that have significantly changed many practices in our lives today. The changes introduced by 20th century technology to everyday life are irreversible with their transformations in communication, education, business life, work, the purchase of goods, entertainment, or in data storage – and of course in agriculture.

The rapidly changing economic and social environment requires a correspondingly constant adaptation from the actors of the economy. This includes vocational education, who prepare many of the workforce for the changing labour markets including agriculture.

This brings a new challenge to the education system, and problems for the future, as agriculture not only requires agrarian engineers and IT professionals, but also the intersection of the two.

The situation for VET schools, as providers of that education, is made more difficult by the fact that many of these tools are expensive, and without tools it is difficult to solve the practical training problems facing students.

Today, employers require workers-to-be to have the key competences that are necessary for employment, i.e. workers with a wide range of practical skills and experience, as well as theoretical knowledge. Economic changes are happening very quickly, so students need to be prepared to be able to adjust to new areas, roles and even new jobs at any time. In response to this, lifelong learning is an essential for tomorrow’s workforce.

The Agritech 4.0 project is intended to help you with exactly this.

In Module 1 of the curriculum, a number of active learning support methods, ICT tools are presented, introducing Open Educational Resources and free online learning repositories. Module 2 provides up-to-date knowledge of the current European agricultural strategies and initiatives, and Module 3 introduces the key concepts, tools and machinery of Agriculture 4.0.

We hope all teacher readers will find useful information within the book that they can make use of in their own teaching practice.

The book was created as a joint work of the Agritech 4.0 project partners.